

# SOUTHWORTH

## PalletPal Pallet Rotator Owner's Manual

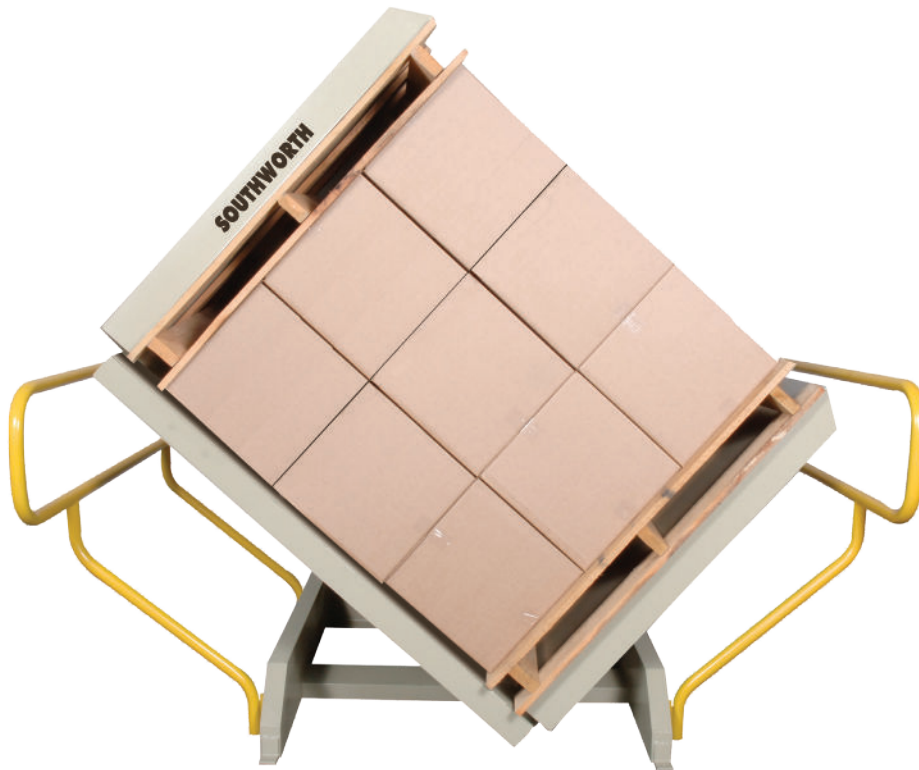

Model: SR-44  
Serial Number: \_\_\_\_\_  
Date placed in service: \_\_\_\_\_

SOUTHWORTH PRODUCTS CORP.  
P.O. Box 1380, Portland, ME 04104-1380  
Telephone: 800-743-1000 • 207-878-0700  
Fax: 207-797-4734  
[www.SouthworthProducts.com](http://www.SouthworthProducts.com)

# Contents

<b>1</b>	<b>Introduction.....</b>	<b>4</b>
1.1	Responsibilities of Owner and Users.....	4
1.2	Responsibilities of Operators.....	5
<b>2</b>	<b>Safety.....</b>	<b>7</b>
2.1	Safety Alert Symbols.....	7
2.2	Signal Words.....	7
2.3	Safety Devices.....	7
<b>3</b>	<b>Labeling.....</b>	<b>8</b>
3.1	Label Placement Diagram.....	8
<b>4</b>	<b>Installation.....</b>	<b>10</b>
4.1	Positioning the Machine.....	11
4.2	Electrical Connections.....	12
4.3	Control Station.....	12
4.4	Testing.....	12
<b>5</b>	<b>Operation.....</b>	<b>14</b>
5.1	Before Each Use.....	14
5.2	Loading.....	14
5.2.1	Load Restrictions.....	14
5.3	Operation Instructions.....	15
<b>6</b>	<b>Maintenance &amp; Repair.....</b>	<b>16</b>
6.1	Periodic Maintenance.....	17
6.1.1	Monthly.....	17
6.1.2	Annually.....	17
<b>7</b>	<b>Troubleshooting.....</b>	<b>18</b>
<b>8</b>	<b>Electrical Information.....</b>	<b>19</b>
8.1	Fusing Requirements.....	19
8.2	Wiring Schematics.....	20
8.2.1	Single Phase Wiring Schematic.....	20
8.2.2	Three Phase Wiring Diagram.....	21
<b>9</b>	<b>Hydraulics.....</b>	<b>22</b>
9.1	Hydraulic Power Unit.....	22
9.2	Hydraulic Schematic.....	23
<b>10</b>	<b>Warranty &amp; Contact Information.....</b>	<b>24</b>



**This label (part # 10095524)  
is required by California law.  
For more information visit  
[www.P65Warnings.ca.gov](http://www.P65Warnings.ca.gov).**

# 1. Introduction

## 1.1 Responsibilities of Owner and Users

**Basic Principles** - Owners/users shall apply sound principles of safety, training, inspection, maintenance, and expected operating environment. It shall be the responsibility of the owner/user to advise the manufacturer where deflection may be critical to the application.

**Manuals** - Owners/users shall keep and maintain a copy of the operating and maintenance manual(s) and ensure its availability to operating and maintenance personnel.

**Inspection and Maintenance** - It shall be the responsibility of the users to inspect and maintain the machine as required to ensure proper operation. The frequency of inspection and maintenance shall be based upon the manufacturer's recommendations and be compatible with operating conditions and the severity of the operating environment. Machinery that is not in proper operating condition shall be immediately removed from service until repaired. Maintenance and repairs shall be made by a qualified person and the repairs shall be in conformance with the manufacturer's recommendations.

**Maintenance Safety Precautions** - Before adjustments and repairs are started on the machine, the following precautions shall be taken as applicable:

1. Remove the load from the platform.
2. Rotate the clamp mechanism to the maintenance position and secure using the maintenance chains.
3. Relieve system pressure from all circuits before loosening or removing any components.
4. All controls in the "off" position and all operating features secured from inadvertent motion by brakes, blocks, or other means.
5. Disconnect power and follow established owner/user lockout/tag out policies.
6. Follow precautions and directions as specified by the manufacturer.

**Replacement Parts** - When parts or components are replaced, they shall be replaced with parts or components approved by the original manufacturer.

**Maintenance Training** - The user shall ensure only qualified personnel inspect and maintain the machine in accordance with the manufacturer's recommendations.

**Operator Training** - An owner/user, who directs or authorizes an individual to operate the machine shall ensure that the individual has been:

1. Trained in accordance with the manufacturer's operating manual.
2. Made aware of the responsibilities of operators as outlined in section 1.4 of this manual.
3. Retrained, if necessary, based on the owners/user's observation and evaluation of the operator.

**Modifications** and additions shall not be performed without the manufacturer's prior written approval. Where such authorization is granted, capacity, operation, and maintenance instruction plates, tags, or decals shall be changed accordingly.

## 1.2 Responsibilities of Operators

**Basic Principles** - Operators shall apply sound principles of safety and good judgment in the application and operation of the machine with consideration given to its intended use and expected operating environment. Since the operator is in direct control of the machine, conformance with good safety practices is the responsibility of the operator. The operator shall make decisions on the use and operation with due consideration for the fact that his or her own safety as well as the safety of other personnel on or near the machine is dependent on those decisions.

**General Training** - Only personnel who have received general instructions regarding the inspection, application, and operation of machine, including recognition and avoidance of hazards associated with their operation, shall operate the machine. Such topics covered shall include, but not necessarily be limited to, the following issues and requirements:

1. A pre-start inspection
2. Responsibilities associated with problems or malfunctions affecting the operation of the machine
3. Factors affecting stability
4. The purpose of placards and decals
5. Workplace inspection
6. Safety rules and regulations
7. Authorization to operate
8. Operator warnings and instructions
9. Actual operation of the machine; Under the direction of a qualified person, the trainee shall operate the machine for a sufficient period of time to demonstrate proficiency in actual operation of the machine.

**Pre-start Inspection** - Before use each day or at the beginning of each shift, the machine shall be given a visual inspection and functional test including but not limited to the following:

1. Operating and emergency controls
2. Safety devices
3. Hydraulic system leaks
4. Electrical cables and wiring harness
5. Loose or missing parts
6. Nameplates, precautionary and instructional markings and/or labeling
7. Guarding system
8. Items specified by the manufacturer

**Problem or Malfunctions** - Any problems or malfunctions that affect the safety of operations shall be repaired prior to the use of the machine.

**Before Operations** - The operator shall:

1. Read and understand the manufacturer's operating instruction(s) and user's safety rules or have them explained.
2. Understand all labels, warnings, and instructions displayed on the machine or have them explained.

**Workplace Inspections** - Before the machine is used and during use, the operator shall check the area in which the machine is to be used for possible hazards such as, but not limited to:

1. Bumps, floor obstructions, and uneven surfaces
2. Overhead obstructions and electrical hazards
3. Presence of unauthorized persons
4. Other possible unsafe conditions as noted in the operating manual

**Operator Warnings and Instructions** - The operator shall ensure the operation of the machine is in compliance with the following:

1. **Guarding system** - Guarding shall be installed and positioned, and access gates or openings shall be secured per the manufacturer's instructions (If applicable).
2. **Distribution of load** - The load and its distribution on the platform shall be in accordance with the manufacturer's rated capacity for that specific configuration.
3. **Maintaining overhead clearance** - The operator shall ensure that adequate clearance is maintained from overhead obstructions and energized electrical conductors and parts.
4. **Point of Operation** - The operator shall not place any part of their body under the platform or near the rotating mechanism.
5. **Precaution for moving equipment** - When other moving equipment or vehicles are present, special precautions shall be taken to comply with the safety standards established for the workplace.
6. **Reporting problems or malfunctions** - The operator shall immediately report to a supervisor any problem(s) or malfunction(s) that become evident during operation. The operator shall ensure all problems and malfunctions that affect the safety of operations are repaired prior to continued use.
7. **Capacity limitation** - Rated capacity shall not be exceeded when loads are transferred to the platform.
8. **Work area** - The operator shall ensure the area surrounding the machine is clear of personnel and equipment before lowering the platform.
9. **Securing the machine** - The operator shall comply with the means and procedures provided to protect against use by an unauthorized person(s).
10. **Altering safety devices** - Safety devices shall not be altered or disabled.
11. **Modifications** or alterations of the machine or the fabrication and attaching of frameworks or the mounting of attachments to the machine or the guarding system shall only be accomplished with prior written permission of the manufacturer.
12. **Assistance to the operator** - If an operator encounters any suspected malfunction or any hazard or potentially unsafe condition relating to capacity, intended use, or safe operation, the operator shall cease operation of the machine and request further instruction from the owner/user.
13. **Problems or malfunctions** - Any problem(s) or malfunction(s) that affect the safety of operations shall be repaired prior to the use of the machine.

## 2. Safety

All personnel installing, operating, and maintaining this machine shall read and understand this manual. For questions or concerns contact the manufacturer.

This machine shall be installed, operated, and maintained by trained and/or qualified personnel only.

### 2.1 Safety Alert Symbols

A symbol that indicates a hazard. It is composed of an equilateral triangle surrounding an exclamation mark. The safety alert symbol is only used on hazard alerting signs. It is not used on safety notice and safety instructions signs.



**A** – For use with **DANGER** signal word; (safety white triangle, safety red exclamation mark, safety red background)

**B** – For use with **WARNING** signal word; (safety black triangle, safety orange exclamation mark)

**C** – For use with **CAUTION** signal word; (safety black triangle, safety yellow exclamation mark)

**D** – For use with **DANGER, WARNING, or CAUTION** signal words; (**D** is a safety yellow triangle with a safety black border and safety black exclamation mark;

### 2.2 Signal Words



**DANGER** Indicates a hazardous situation that, if not avoided, will result in death or serious injury.



**WARNING** Indicates a hazardous situation that, if not avoided, could result in death or serious injury.



**CAUTION** Indicates a hazardous situation that, if not avoided, could result in minor or moderate injury.



**NOTICE** Indicates information considered important, but not hazard-related (e.g., messages relating to property damage).

### 2.3 Safety Devices

This machine is equipped with devices and features to protect the operator and nearby personnel from severe injury or death. These features and devices shall be installed and functioning correctly during operation.

Maintenance Chains:	Used to secure the rotating mechanism against movement during maintenance and repair.
Guard Rails:	Protects the operator, and nearby personnel, from access during operation.
Emergency Stop	Located on the control station. Press this button to immediately stop the machine during an emergency.

### 3. Labeling

This machine has labeling to indicate potential hazards this machine may pose when operating and/or maintaining the machine. All labels must be legible. If any label is missing, damaged, or otherwise illegible contact the manufacturer for replacement labels.

#### 3.1 Label Placement Diagram

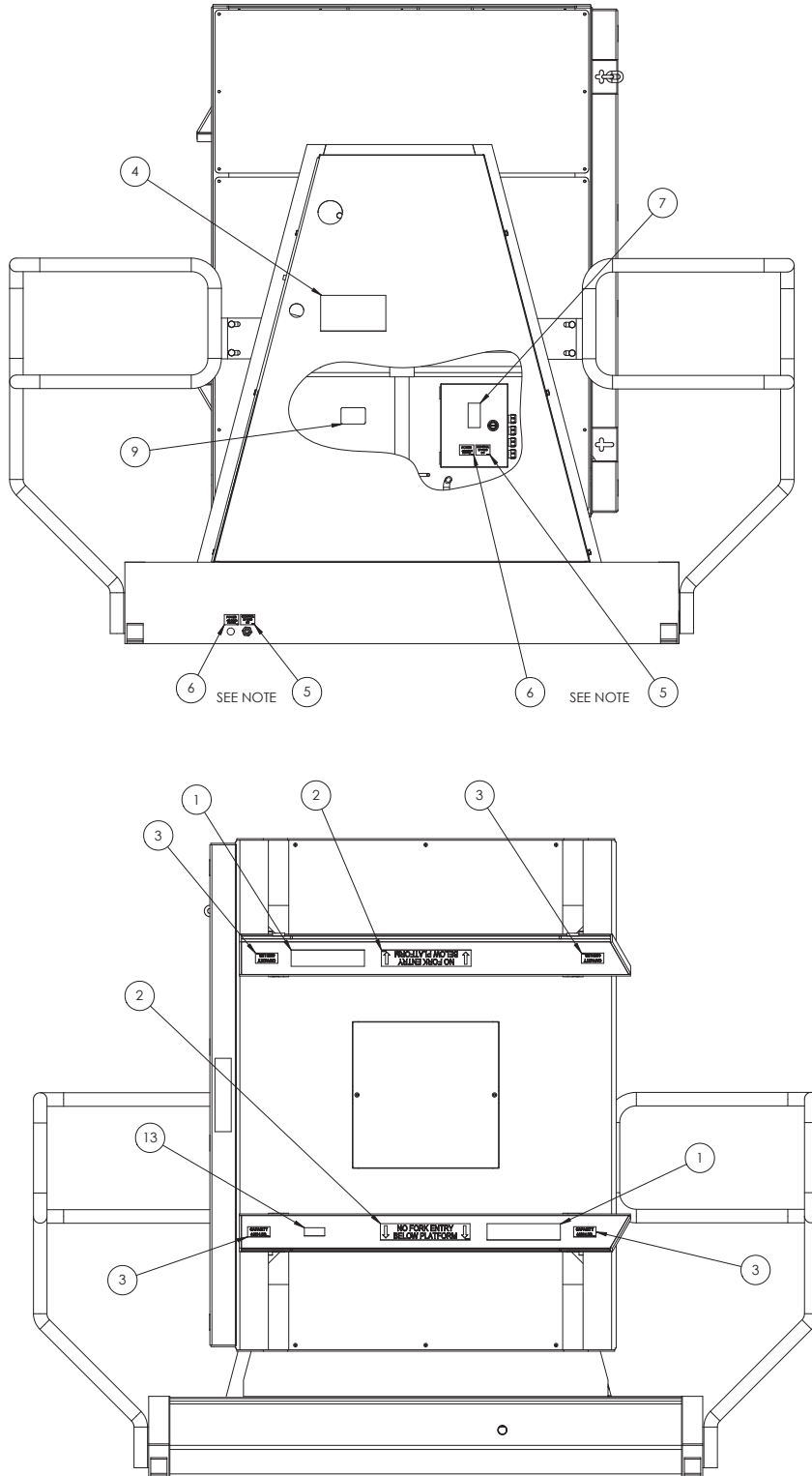



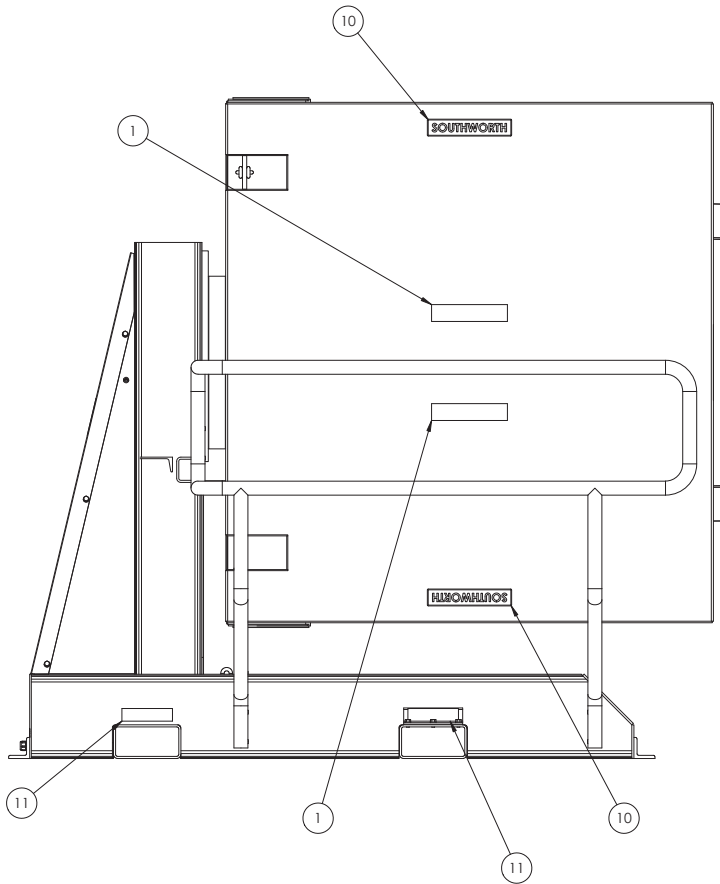

12 10021381 TO BE APPLIED TO 115/1/60 POWER MACHINES ONLY. PLACE ON POWER CORD 1" FROM PLUG.

ITEM NO.	QTY.	U/M	DESCRIPTION	PART NO.
13	1	EA	LD WARNING CANCER AND REPRODUCTIVE	10095524
12	1	EA	BK-LD DCL 2.50X12.75 (ENGLISH AND SPANIS	10021381
11	4	EA	LD DCL 1.50X6.00 FORK ENTRY - LIFT HERE	10039033
10	2	EA	BK-LD TAG 2.00X10.00 SOUTHWORTH	5900158
9	1	EA	LD DCL 2.00X3.00 SOUTHWORTH SERIAL ID BL	10079929
8	1	EA	BK-LD DCL 1.50X5.50 TANK TO BE FULL ONLY	2986997
7	1	EA	BK-LD DCL 3.00X1.50 ARC FLASH AND SHOCK	10047672
6	2	EA	BK-LD DCL 1.25X1.75 POWER	
5	2	EA	BK-LD DCL 1.25X1.75 CONTROL	
4	1	EA	LD DCL 4.50X8.00 CLOCKWISE FOR HIGHER CL	10039039
3	4	EA	LD DCL 1.25X2.75 CAPACITY 4400 LBS	10039022
2	2	EA	LD DCL 2.00X11.00 NO FORK ENTRY BELOW PL	10039031
1	REF		LD DCL 2.00X9.00 STAND CLEAR WHILE INVER	10039041

5 CONTROL  
115/1/60  
1 PHASE

CONTROL DECALS	
VOLTAGE	ITEM NO.
115/1/60	2986999
24/1/60	2986998
24 VDC	5900166
110/1/50	5900167

LOCATE CONTROL DECAL SPECIFIC TO MACHINE AS SHOWN. TWO PLACES

6 POWER  
460 VOLTS  
3 PHASE

POWER DECALS	
VOLTAGE	ITEM NO.
115/1/60	2987000
230/1/60	5900160
208/3/60	2987001
230/3/60	2987002
460/3/60	2987003
575/3/60	5900162
12 VDC	2991783
24 VDC	5900161
110/1/50	5900163
220/1/50	5900164
380/3/50	2999416
415/350	5900165

LOCATE POWER DECAL SPECIFIC TO MACHINE AS SHOWN. TWO PLACES

## 4. Installation

Unless otherwise stated, this machine shall only be used indoors in normal industrial conditions. It must not be exposed to the elements.

The owner/ installer is responsible for ensuring all codes and ordinances are met and any necessary permits are obtained prior to installation.

This machine shall be installed and operated on a solid, level surface capable of supporting the machine and its maximum rated capacity.

**Before Installation** read and understand this manual. **Only trained and/or qualified personnel shall install this machine.** Remove all packaging and inspect the machine for damage and/ or missing components. Contact the manufacturer if damage is found or components are missing.

Use proper Personal Protective Equipment when installing this machine.



**High Voltage: Electrical service and installation must be performed by trained and/ or qualified personnel. Lock-out/ tag-out the power source before installation.**

Electric motors can create sparking, do not install in an area where flammable materials are present.

This machine must be installed and operated indoors and in an area protected from rain and moisture.

Do not sit, stand, or ride on the platforms.

Do not enter within the guardrails unless the machine has been secured with the maintenance chains and the machine has been deenergized.

The hydraulic pressure relief valve has been set during manufacturing. Do not modify, adjust, or remove the pressure relief valve. An improperly adjusted relief valve may lead to product damage and/or operator injury.

115 volt, single phase machines equipped with 3.2 horsepower power units require a dedicated 30 amp breaker.

Do not power this machine with an extension cord or the motor and other electrical components may be damaged.

When placing this machine, take care not to locate it in an area that may magnify the noise of the machine.

Anchoring of this machine is not necessary for safe operation. However, the machine may move during operation because of machine vibration, starting and stopping load impulses, and loading with fork trucks. If necessary, the machine may be anchored so that it remains in position. Anchors to be provided by the installer.

### NOTICE

## 4.1 Positioning the Machine

1. Unfasten the machine from the shipping skid.
2. Verify area is clear of tools, debris, and personnel.
3. Using an appropriately rated fork truck, insert the forks into the fork pockets located on the sides of the machine. Forks can be inserted in either direction.

**NOTICE** Approximate weight on machine: 4,800 lb.

4. Raise the machine only enough to clear the shipping skid and transport the machine to the desired location.
5. Carefully lower the machine onto the floor.

### If anchoring the machine:

6. Mark the locations of the four anchor points, located at each end of the outriggers, and drill holes according to the lag bolt manufacturer's specifications.
7. Insert and tighten the lag bolts according to the lag bolt manufacturer's specification.
8. Install the guardrails using the supplied hardware (both sides of machine).

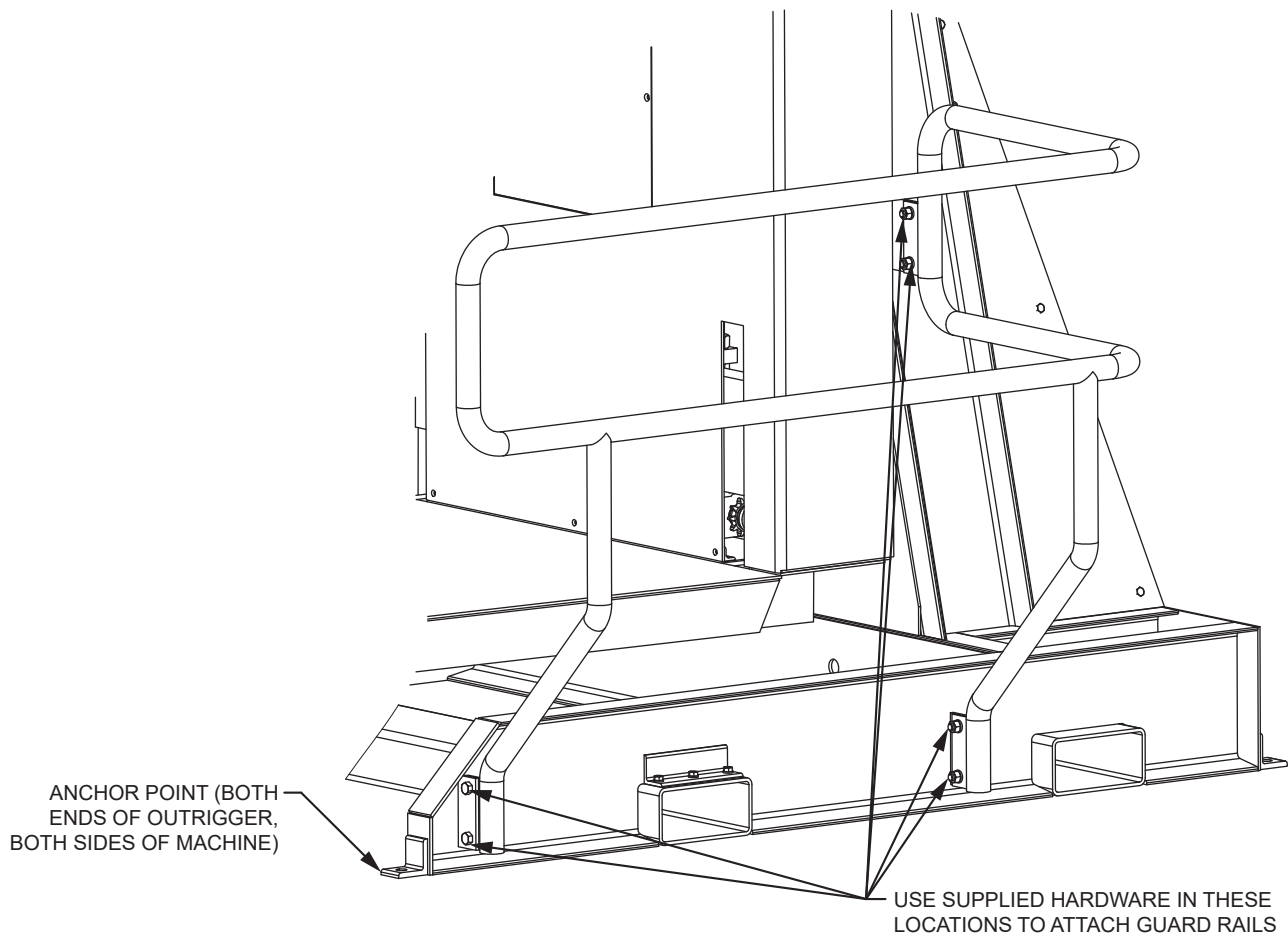

## 4.2 Electrical Connections

### **NOTICE**

The owner/installer is responsible for providing a fused disconnect switch. See section 8.1 Fusing Requirements.

Single phase machines must be connected to a dedicated circuit. Operating other equipment on the same circuit can cause excessive voltage drops and damage electrical components.

Make all connections according the wiring schematic. See section 8.2 Wiring Schematics.

## 4.3 Control Station

The control is shipped pre-wired to the machine. The control station must be placed in a location that allows the operator to see the load during operation but does not interfere with loading, unloading, and operation.

Mount the control station to the floor using the four mounting holes in the base plate. Anchors to be provided by installer.

## 4.4 Testing

### **NOTICE**

Ensure all tools, personnel, and debris are clear of the area.

During operation the movements should be smooth. Some bouncing/ stuttering may occur during initial operation caused by air in the hydraulic system. The air will bleed out of the system after several cycles.

If the machine does not begin to rotate/clamp within several seconds of pressing the button, immediately release the button and consult section 7. Troubleshooting.

Verify the maintenance chains are disengaged before operating the machine.

1. Disengage the maintenance chains.
2. Turn on the main disconnect switch to power the machine.
3. Verify all personnel and debris are clear of the machine.
4. Press and hold the "Rotate CW" button. While the machine is rotating, press the emergency stop button. The machine should stop rotating and no longer function.
5. Verify the machine is completely disabled by pressing each control button, the machine must not operate while the emergency stop is activated.
6. Reset the emergency stop button. Press and hold the "Rotate CW" button until the rotator mechanism reaches the end of travel.
7. Press and hold the "Rotate CCW" button until the rotator mechanism reaches the end of travel. Immediately release the button once the end of travel is reached. Allow the machine to rest for one minute. The machine should hold its position.
8. Press and hold the "Clamp" button until the clamp mechanism is fully clamped. Immediately release the button once the mechanism is fully clamped. Allow the machine to rest for one minute. The machine should hold its position.
9. Press and hold the "Unclamp" button until mechanism is fully opened. Immediately release the button once the mechanism is fully opened.

10. Press and hold the “Rotate CW” button until the rotator mechanism reaches the end of travel.
11. Place a test load onto the platform. Carefully shift the load against the side panel to help prevent the load from shifting during rotation. Use a load that simulates a typical maximum load in size and weight.
12. Verify the fork truck, all personnel, and debris are clear of the machine.
13. Press and hold the “Clamp” button until the load is secure.

**NOTICE**

**Pay close attention while clamping the load. The load must be clamped enough to secure it from falling during rotation. If necessary, clamping pressure can be adjusted using the knob on the rear panel of the machine. Turn knob clockwise to increase pressure; counter clockwise to decrease pressure.**

14. Press and hold “Rotate CCW” button until the load reaches its end of travel. Immediately release the button once the end of travel is reached.
15. Rotate the load to the original position. Unclamp and remove the load. The machine is now ready for normal operation.

## 5. Operation

Only trained and/or qualified personnel shall operate this machine. Personnel operating this machine must read and understand this manual.



Do not sit, stand, or ride on platform.

Crush hazard. Always ensure load is securely clamped before rotating. Do not stand in front of the machine while clamping and rotating.

Guard rails must be installed before operating this machine.

Do not enter within the guardrails unless the machine has been secured with the maintenance chains and the machine has been deenergized.

### 5.1 Before Each Use

- Inspect the machine for excessive wear or damage.
- Verify all precautionary labeling is in place and legible.
- Inspect controls and cords for damage.
- Inspect for hydraulic leaks and loose fittings.
- Inspect controller and cord for damage.
- Verify controls function correctly by rotating and clamping without a load.
- Verify the machine moves smoothly through the rotation and clamping movements.

### 5.2 Loading



Loads must not exceed the maximum load rating.

Before loading, rotate the machine in either direction until it reaches the end of travel. Immediately release the button once the end of travel is reached. The machine must only be loaded and unloaded when the side panel is vertical.

#### 5.2.1. Load Restrictions

Model	Min Load Height	Max Load Height	Max Load Weight
SR44-60	30"	60"	4,400 lb
SR44-72	42"	72"	4,400 lb
SR44-84	54"	84"	4,400 lb

### 5.3 Operation Instructions

1. Press and hold the “Unclamp” button until the clamping mechanism is fully opened.
2. Carefully load the pallet onto the platform using a fork truck. Carefully shift the load against the side panel to help prevent the load from falling during rotation. Do not drop the load onto the platform. Move fork truck clear of the machine.
3. Press and hold the “Clamp” button until the load is securely held by the clamping mechanism. The load should be clamped such that it is securely held in place but not crushed or damaged.

#### **NOTICE**

**Clamp pressure can be adjusted with pressure adjustment knob located on the rear panel of the machine. Turn knob clockwise to increase pressure; counter clockwise to decrease pressure.**

4. Press and hold the “Rotate CW” or “Rotate CCW” buttons to rotate the load. Release the button as soon as the rotator reaches the end of travel.



**Do not unclamp the load until the rotator has rotated the full 180°. Releasing the load early will allow the load to fall out off of the pallet and could lead to injury.**

5. Press and hold the “Unclamp” button until the clamping mechanism is fully opened. Make necessary adjustments to the load.
6. Press and hold the “Clamp” button until the load is securely held by the clamping mechanism.
7. Rotate the load back to the original orientation.
8. Release the clamp and remove the load.

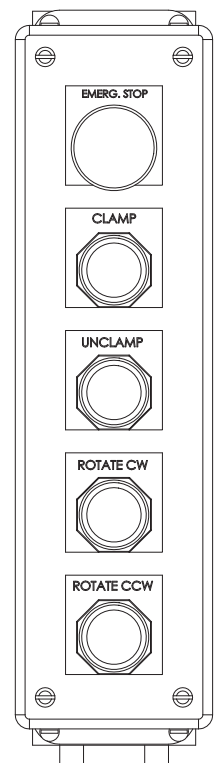
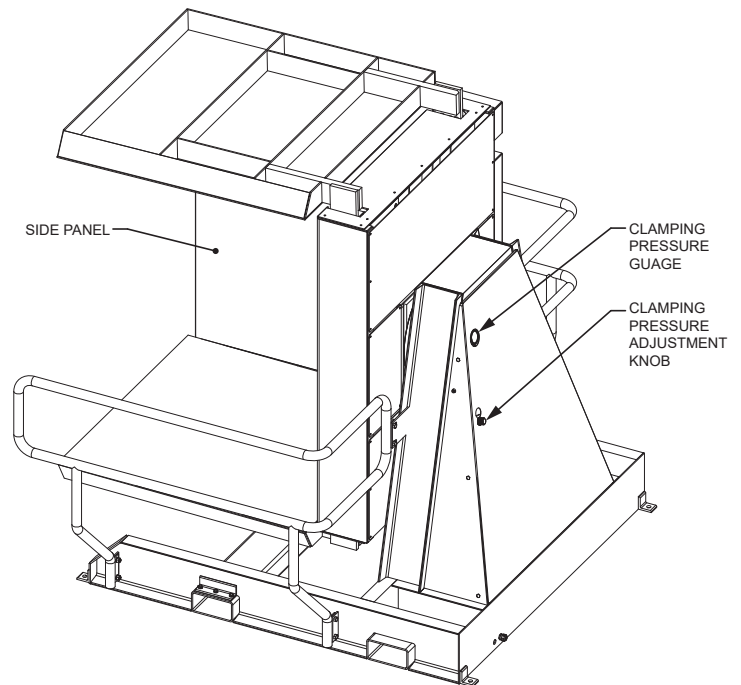

## 6. Maintenance & Repair

Only trained and/ or qualified personnel shall perform any maintenance or repair.



High Voltage can cause severe injury or death. Disconnect and lockout electrical power before performing maintenance or repair.

High pressure fluids can penetrate skin and cause severe injury or death. Always relieve hydraulic system pressure before performing maintenance or repair of the hydraulic system. Contact Customer Service for assistance.

If damage or excessive wear is found, remove the machine from service until the machine is repaired.

Do not enter within the guardrails unless the machine has been secured with the maintenance chains and the machine has been de-energized.

Ensure maintenance chains are removed prior to operation.



Before performing maintenance rotate the machine 90° and secure using the attached chains. Insert chains into the slots in the base of the side platen. Always use chains on both sides of the machine.

Relieving hydraulic system pressure while the rotator mechanism is unsecured will allow it to rotate uncontrolled which could lead to injury and/or damage to the machine. Always secure with maintenance chains before relieving hydraulic pressure.

Once maintenance/repair is complete and if hydraulic system pressure has been relieved, the hydraulic system will need to be re-pressurized before maintenance chains can be removed.



## 6.1 Periodic Maintenance

### 6.1.1. Monthly

- Inspect all hoses and fittings for damage and/or leaks.
- Inspect all wiring and controls.
- Inspect pivot bearing for damage or wear.
- Inspect the rotation hydraulic cylinder for damage or leaks (located behind the rear panel).
- Inspect the clamping hydraulic cylinders (located behind the panel in the rotation assembly).
- Inspect hydraulic power unit, pressure gauge.
- Inspect the hydraulic fluid. The fluid should not be dark, cloudy, or contain debris. Replace as necessary. Fluid level should be approximately one inch from the top of the tank, with the machine in the maintenance position and clamp mechanism fully opened.
- Grease the pivot assembly using the grease points located on the either side of the mast.
- Apply a dry PTFE lubricant to all non-greased pins.
- Inspect rollers and roller tracks for wear or damage.
- Inspect chains, sprockets, and shaft for wear or damage. Repair/replace as necessary.
- Verify proper operation. See section **4.4 Testing**.

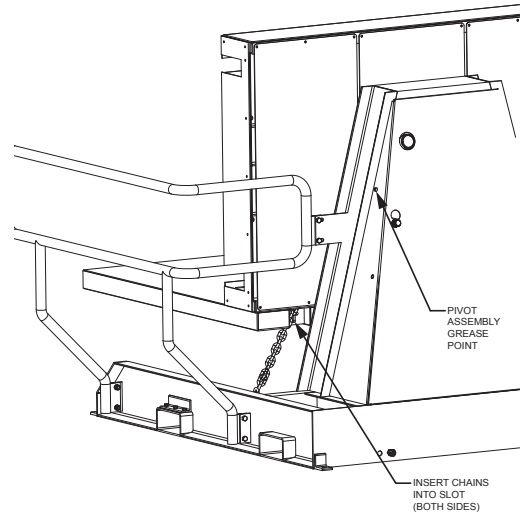

### 6.1.2. Annually

- Replace hydraulic fluid and fluid filter. See section **9. Hydraulics**.

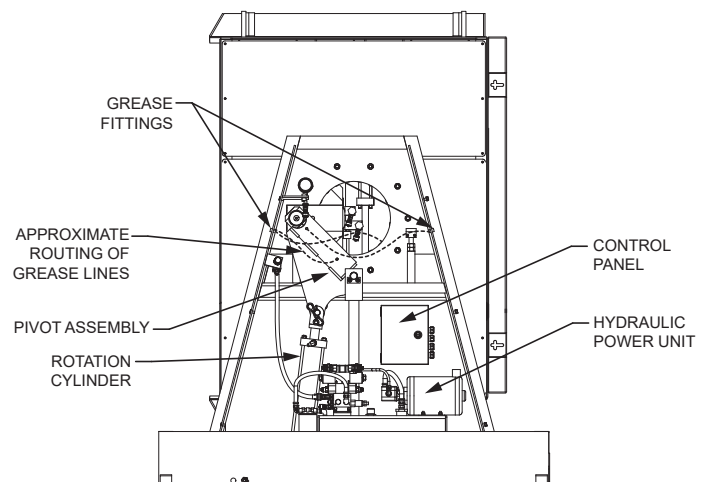
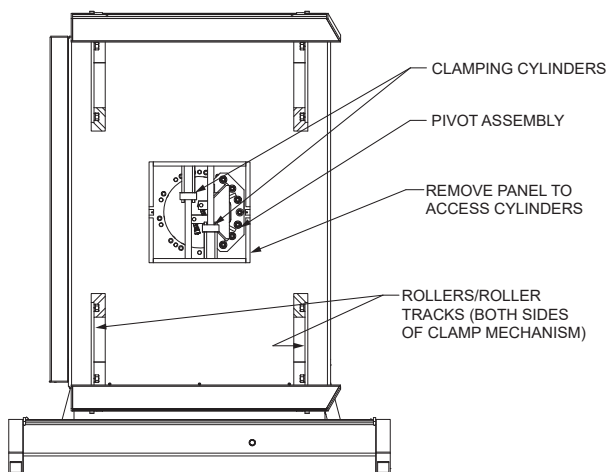

## 7. Troubleshooting

Clamping mechanism will not hold the load	Clamping pressure is too low	Adjust the clamping pressure as necessary using the pressure adjustment knob on the rear of the machine.
	Load is too short for clamp to secure	Verify the load is of a size the machine is capable of securing. See section 5.2.1. Load Restrictions.
Machine will not rotate load (motor runs)	Maintenance chains engaged	Verify the maintenance chains are not engaged.
	Motor may be turning in the wrong direction (three phase machines)	Check motor rotation direction (counter clockwise as viewed from the shaft end of the motor). If motor is rotating the wrong way, swap any two phases.
	The load exceeds the maximum capacity	Verify load weight does not exceed the rated capacity. See section 5.2.1. Load Restrictions.
	Hydraulic fluid level may be low	Check the hydraulic fluid level. Add fluid as necessary. See section <b>9. Hydraulics</b> .
	Pivot assembly may be damaged	Inspect the turret bearing, pivot arm, and hydraulic cylinder for damage.
The machine will not clamp or rotate (motor runs)	Hydraulic fluid level may be low	Check the hydraulic fluid level. Add fluid as necessary. See section <b>9. Hydraulics</b> .
	Maintenance chains engaged	Ensure maintenance chains are disengaged before operating.
	There may be a hydraulic leak	Inspect the hydraulic system for leaks.
	Supply voltage may be low	Verify the supply voltage is within 10% of the rated voltage for three phase machines or 5% of the rated voltage for single phase machines.
	Motor may be turning in the wrong direction (three phase machines)	Check motor rotation direction (counter clockwise as viewed from the shaft end of the motor). If motor is rotating the wrong way, swap any two phases.
The machine will not clamp or rotate (motor does not run)	Emergency stop may be pressed	Verify the emergency stop button is not pressed.
	Controls may not be functioning	Inspect the controller and control cord for damage. Repair or replace as necessary.
	The machine may not be receiving power	Verify the machine is receiving the correct supply voltage. Supply voltage must be within 10% of the rated voltage for three phase machines or 5% of the rated voltage for single phase machines.

## 8. Electrical Information

Motor Horsepower	3.2
Control Voltage	115/1/60
Primary Voltage	Varies

### 8.1 Fusing Requirements

**NOTICE**

**Suggested dedicated circuit breaker sizing. Always refer to local code regarding necessary circuit breaker requirements.**

Nominal Supply Power	Full Load Amps	Required Breaker
115/1/60	27	30
208/1/60	14.3	20
230/1/60	13.5	20
208/3/60	8.4	15
230/3/60	8	15
460/3/60	4	15
190/3/50	9.4	15
380/3/50	4.7	15

**NOTICE**

**Ensure the motor overload relay is set for the correct full load amps for the given primary voltage.**

## 8.2 Wiring Schematics

### 8.2.1. Single Phase Wiring Schematic

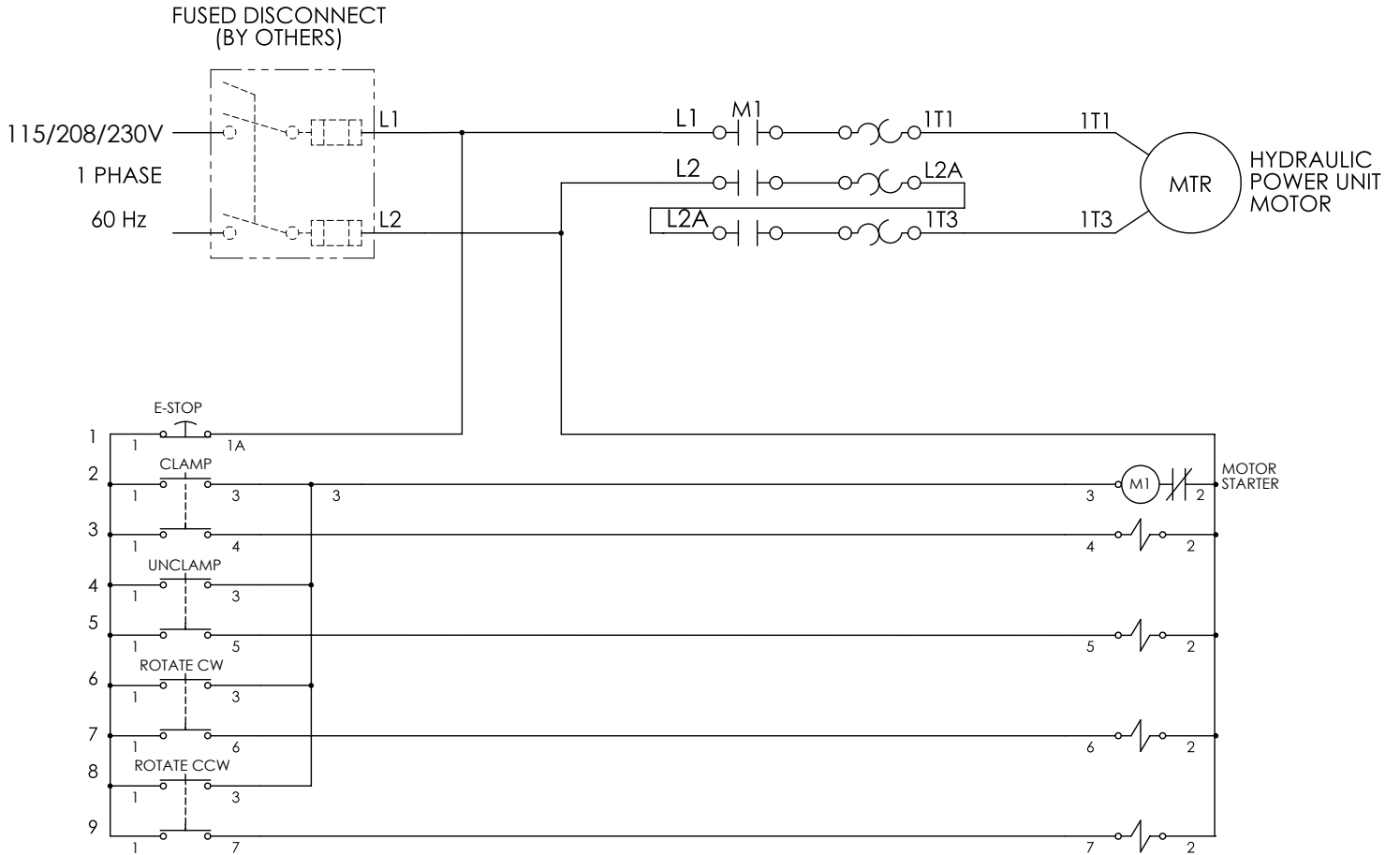

#### NOTES:

- SUPPLY POWER CONNECTS TO 1L1,3L2 AT TOP OF MOTOR CONTACTOR.
- SUPPLY GROUND CONNECTS TO GROUNDING TERMINAL IN CONTROL PANEL

## 8.2.2. Three Phase Wiring Diagram

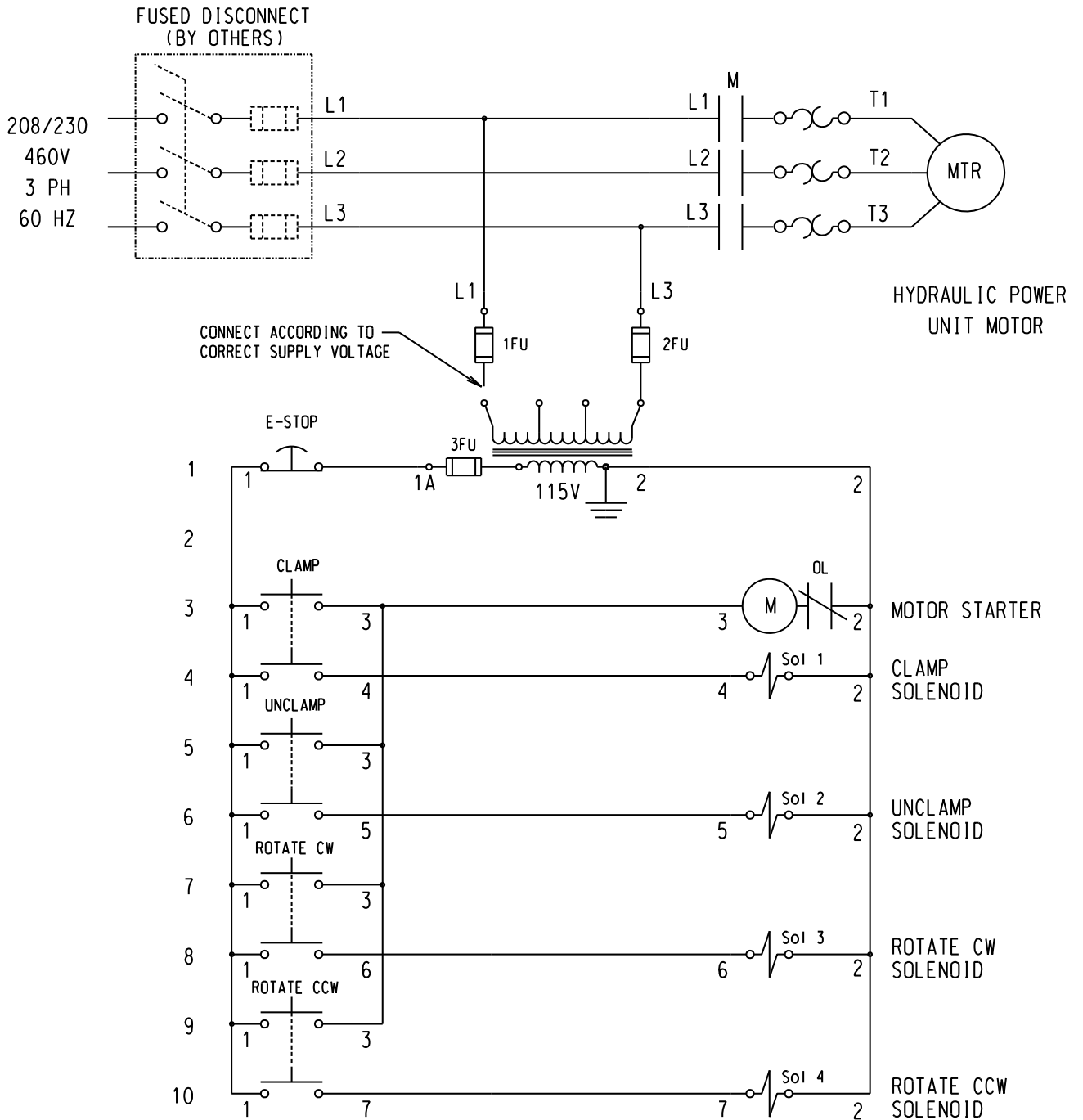

### NOTES:

- SUPPLY PHASES CONNECT TO 1L1, 3L2, 5L3 AT TOP OF MOTOR CONTACTOR
- SUPPLY GROUND CONNECTS TO GROUNDING TERMINAL IN CONTROL PANEL

## 9. Hydraulics

Pump Capacity: 1.7GPM

Tank Capacity: 2.4 Gal

Fluid Type: Conoco AW32 (Or equivalent)

Fluid Filter: Zinga BE-10-18 (Or equivalent)

Fluid to be approximately one inch from top of tank when machine is in the maintenance position with maintenance chains engaged and clamp mechanism fully opened.

When adding fluid cycle the machine through a full clockwise and counterclockwise rotation, and full clamp and unclamp functions. Recheck fluid, refill as necessary. Repeat until fluid level is consistently one inch from the top of the tank.

### 9.1 Hydraulic Power Unit

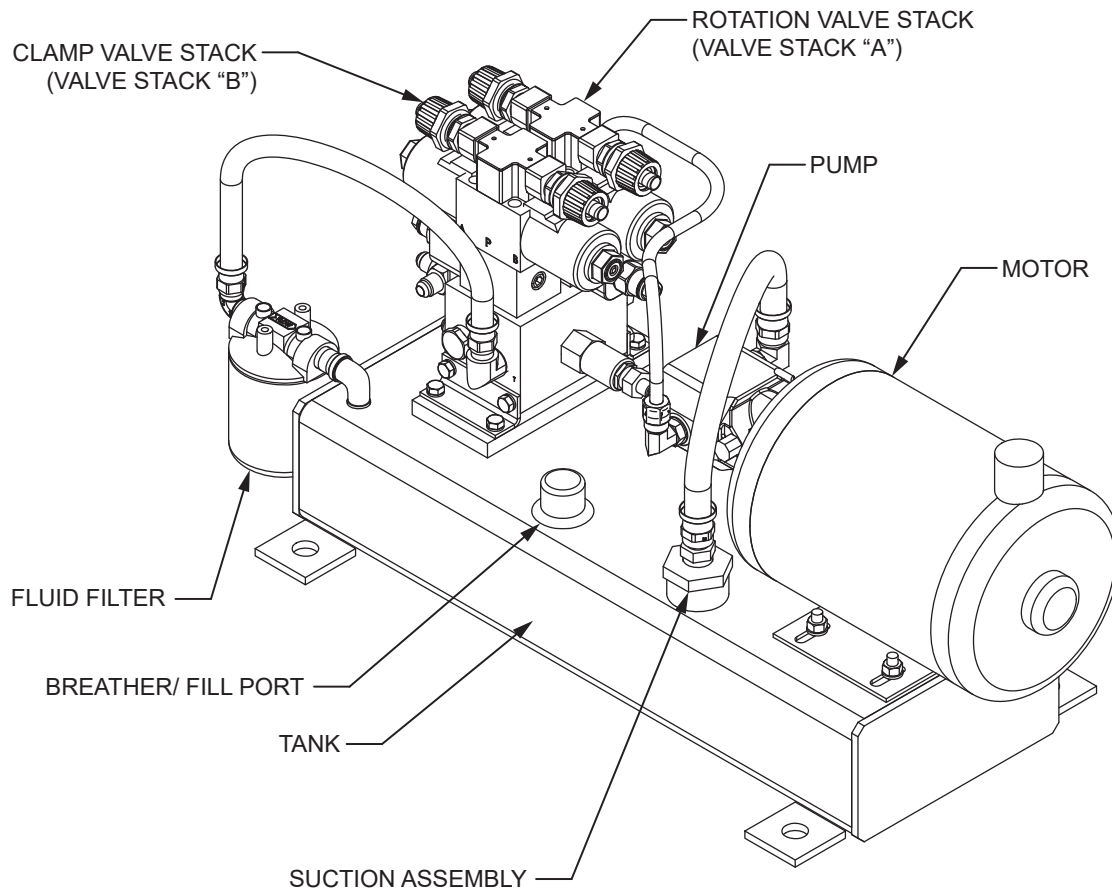

## 9.2 Hydraulic Schematic

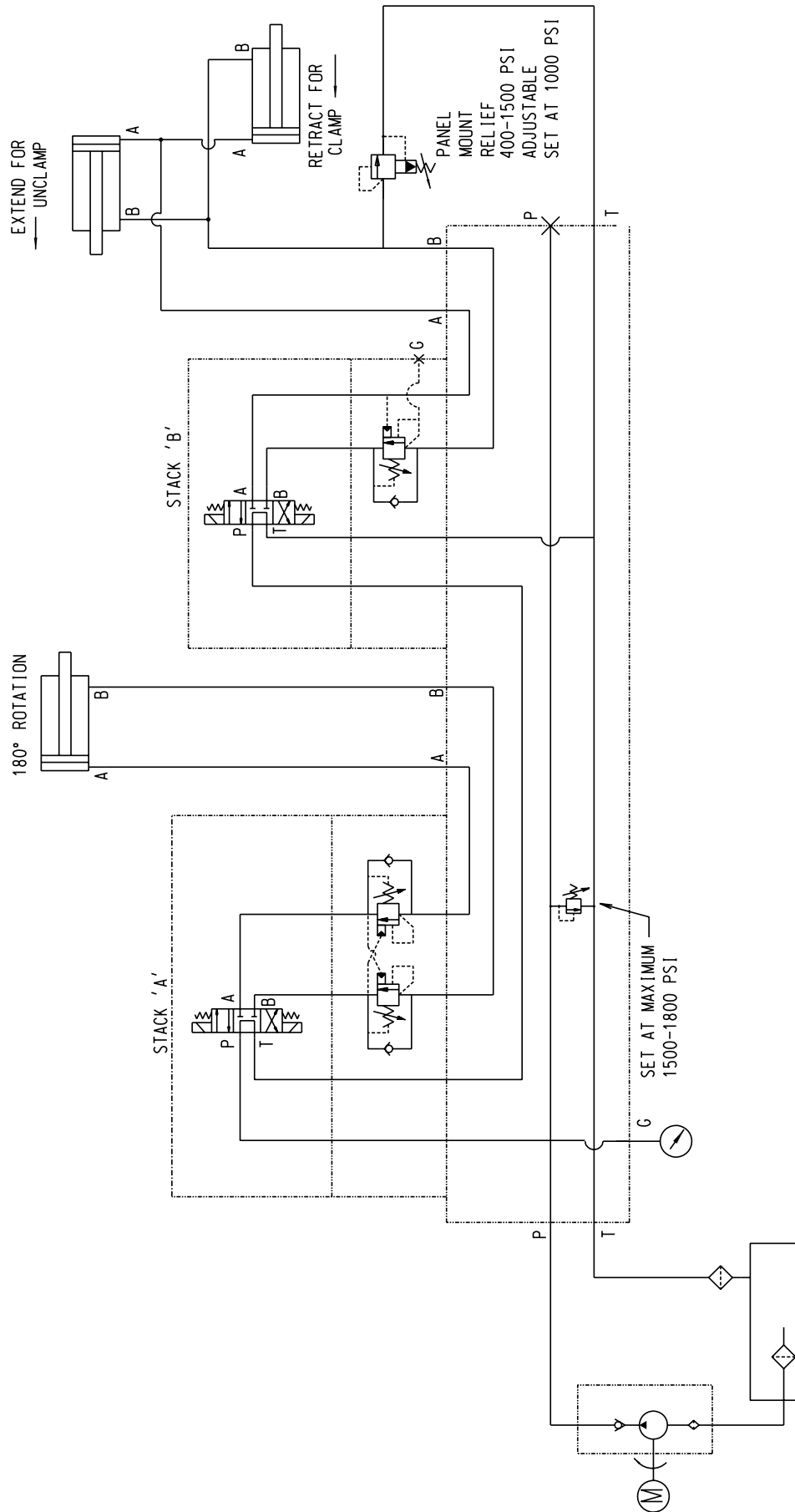

## 10. Warranty & Contact Information

Southworth Products Corp. warrants this product to be free from defects in material or workmanship for the duration of the warranty period. Warranty periods vary and begin on the date of shipment. For specific warranty information, contact Southworth Products with the machine's serial number.

Any claim for breach of this warranty must be received in writing by Southworth within the warranty period. Warranties shall not cover failure or defective operation, caused by misuse, misapplication, negligence or accident, exceeding recommended capacities, or any alteration or repair of the item purchased which has not been authorized by Southworth. Except as set forth herein, Southworth makes no other warranties, express or implied, including THE WARRANTIES OF MERCHANTABILITY AND OF FITNESS FOR A PARTICULAR PURPOSE, all of which ARE HEREBY EXCLUDED.

Southworth meets the labeling requirements of California's Proposition 65. Southworth makes no warranty or representation with respect to the compliance of any product with other State or local safety or product standard codes and any failure to comply with such codes shall not be considered a defect of material or workmanship under this warranty. Southworth shall not be liable for any direct or consequential damages arising out of such non-compliance.

Southworth's obligations under any warranty or for any other damages which may arise under any sale, agreement, or contract, are limited to the replacement or repair of defective components at its factory or another location at Southworth's discretion. This is buyer's sole remedy under any such warranty, sale, agreement, or contract. Southworth will not be liable for consequential, incidental, exemplary, or punitive damages of any kind resulting from a breach of any warranty that it has provided or for breach of any term of any sale, agreement, or contract. Any warranty may be altered only in writing by Southworth.

All commodities, software, or technology purchased from Southworth are subject to the export and re-export control laws and regulations of the United States, including but not limited to the Export Administration Regulations ("EAR") and Department of the Treasury Office of Foreign Asset Controls ("OFAC") Regulations. Southworth expects all distributors and customers to comply with these laws and regulations. Without limiting the foregoing, the distributor/customer cannot, without proper authorization from the applicable United States Government Agency, export, re-export, or transfer any commodity, software, or technology purchased from Southworth, either directly or indirectly, to any entity, country, or national of any country in breach of such laws and regulations. Furthermore, Southworth expects that the distributor/customer shall indemnify and hold harmless Southworth from and against any claim, proceeding, action, fine, loss, cost and damages arising out of or relating to any noncompliance with export control regulations by distributor/customer, and distributor/customer are expected to compensate Southworth for all losses and expenses resulting thereof, unless such noncompliance was clearly not caused by fault of the distributor/customer.

# **SOUTHWORTH**

SOUTHWORTH PRODUCTS CORP.  
P.O. Box 1380, Portland, ME 04104-1380  
Telephone: 800-743-1000 • 207-878-0700  
Fax: 207-797-4734  
[www.SouthworthProducts.com](http://www.SouthworthProducts.com)