

SOUTHWORTH

Hydraulic Lift & Tilt Owner's Manual



SOUTHWORTH PRODUCTS CORP

PO Box 1380, Portland, ME 04104-1380

Telephone: 1-800-743-1000 or 207-878-0700

Fax: 207-797-4734

www.SouthworthProducts.com

service@SouthworthProducts.com

June 2015

Please note: This manual was current at the time of printing. To obtain the latest, most updated version, please contact Southworth's Customer Service Department or go to our website: www.SouthworthProducts.com, under Parts & Service you will find a complete list of current owner's manuals to print.

Contents

INTRODUCTION	4
RESPONSIBILITY OF OWNERS AND USERS	5
SAFETY	6
Safety Considerations	6
Safe Servicing of the Lift	7
INSTALLATION & OPERATING INSTRUCTIONS	8
Positioning the Lift.....	8
Hydraulic Connections	8
Electrical Connections.....	9
Testing.....	9
Completing Installation.....	9
Safety Alert Symbols and Signal Words.....	10
MAINTENANCE.....	12
Hazards.....	12
Routine periodic maintenance.....	12
Maintenance for machines with high cycle pkg.....	13
Maintenance for units with air motors	13
TROUBLESHOOTING.....	14
If the machine will not raise.....	15
The machine elevates but fails to hold a load	15
The machine fails to lower	15
ORDERING REPLACEMENT PARTS.....	16
WARRANTY	34

List of Figures

Fig. 1. Safe Servicing of Lift.....	7
Fig. 2. Hydraulic Pump and Down Valve	9
Fig. 3. Labels and Precautionary Markings	11
Fig. 4. Units with Air Motors.....	13
Part I: Single Acting Tilter	
Fig. 5. Electrical connections for single phase AC.....	18
Fig. 6. Electrical connections for three phase AC.....	19
Fig. 7. Electrical connections for single phase AC.....	20
Fig. 8. Electrical connections for three phase AC.....	21
Part II: Double Acting Tilter	
Fig. 9. Electrical connections for single phase AC.....	23
Fig. 10. Electrical connections for three phase AC.....	24
Fig. 11. Hydraulic connections for single phase AC & three phase AC	25
Part III: Upender	
Fig. 12. Electrical connections for single phase AC.....	27
Fig. 13. Electrical connections for three phase AC.....	28
Fig. 14. Hydraulic schematic for single phase AC & three phase AC	29
Part IV: Lift / Tilt	
Fig. 15. Electrical connections for single phase AC.....	31
Fig. 16. Electrical connections for three phase AC.....	32
Fig. 17. Hydraulic schematic for single phase AC & three phase AC	33

INTRODUCTION

This manual contains information to acquaint you with the safe and proper installation, use and upkeep of the machine. You should ensure that this manual is available to personnel working with the machine and require its use by these personnel.

In the interest of safety, please read this entire manual carefully and be familiar with its contents before you install, use or service the machine. If you have any questions about any instructions in this manual, please contact your dealer or Southworth Products Corp.

Southworth's product warranty is provided in the back of this manual. This instruction manual is not intended to be or to create any other warranty, expressed or implied, including any implied warranty of merchantability or fitness for a particular purpose, all of which are hereby expressly excluded.

As set forth more specifically in the product warranty, Southworth's obligation under that warranty is limited to the repair or replacement of defective components, which shall be the buyer's sole remedy. Southworth shall not be liable for any loss, injury or damage to persons or property, nor for any direct, indirect or consequential damage of any kind resulting from the lift table.

Responsibility of Owners and Users

Inspection and Maintenance

The device shall be inspected and maintained in proper working order in accordance with Southworth's owner's manual.

Removal from Service

Any device not in safe operating condition such as, but not limited to, excessive leakage, missing rollers, pins, or fasteners, any bent or cracked structural members, cut or frayed electric, hydraulic, or pneumatic lines, damaged or malfunctioning controls or safety devices, etc. shall be removed from service until it is repaired to the original manufacturer's standards.

Deflection

It is the responsibility of the user/purchaser to advise the manufacturer where deflection may be critical to the application.

Repairs

All repairs shall be made by qualified personnel in conformance with Southworth's instructions.

Operators

Only trained personnel and authorized personnel shall be permitted to operate the lift.

Before Operation

Before using the device, the operator shall have:

- Read and/or had explained, and understood, the manufacturer's operating instructions and safety rules.
- Inspected the device for proper operation and condition. Any suspect item shall be carefully examined and a determination made by a qualified person as to whether it constitutes a hazard. All items not in conformance with Southworth's specification shall be corrected before further use of the equipment.

During Operation

The device shall only be used in accordance with this owner's manual.

- Do not overload.
- Ensure that all safety devices are operational and in place.

Modifications or Alterations

Modifications or alterations to any Southworth industrial positioning equipment shall be made only with written permission from Southworth.

SAFETY

The safety of all persons operating, maintaining, repairing or in the vicinity of the machine is of paramount concern to Southworth. This is a powerful machine with moving parts and is capable of causing personal injury if proper precautions are not taken. Therefore, throughout this manual, Southworth has identified certain hazards that may occur in the use of this machine and provided appropriate instruction or precautions that should be taken to avoid these hazards. In some cases, Southworth has also pointed out the consequences that may occur if Southworth's instructions or precautions are not followed. Southworth uses the following system of identifying the severity of the hazards associated with its products

SIGNAL WORD

The word or words that designates a degree or level of hazard seriousness. The signal words for product safety signs are "**DANGER, WARNING** and **CAUTION.**"



Immediate hazard which will result in severe personal injury or death.



Hazardous or unsafe practice which could result in severe personal injury or death.



Hazardous or unsafe practice that could result in minor personal injury or property damage.

Please read and follow the instructions in this manual, including all safety instructions and precautions carefully and completely.

SAFETY CONSIDERATIONS

Southworth Hydraulic Lift tables are designed and manufactured to meet the safety requirements of the *ANSI Standard MH29.2-2000, Industrial Tilters*.

Southworth Hydraulic Lift Tables are equipped with a pressure safety relief valve so overloading will not "burst" the air bag.

Southworth Hydraulic Lift Tables have a safety orifice speed control. This regulates the down speed. Should an air line rupture, the unit will descend at about the normal rate. This orifice is not adjustable.

All Southworth Hydraulic Lift Tables can be fitted (optional) with industrial, high quality dampers to provide smooth movement even when loads are abruptly introduced to the platform.

Southworth units are also equipped with safe, reliable Firestone air spring actuators rather than vinyl air bags.

All Southworth models are designed with a generous safety factor of three to one.

SAFE SERVICING OF THE LIFT

⚠️ WARNING

Only authorized personnel should perform inspection or maintenance and service procedures. Unauthorized personnel attempting these procedures do so at the risk of severe injury or death.

⚠️ DANGER

Failure to properly adhere to lift blocking procedures is to risk the sudden and uncontrolled descent of the lift during maintenance or inspection. A falling lift can cause severe injury or death.

This procedure describes the only factory-approved method of working under a lift. Follow these instructions **EVERY** time you plan to reach or crawl beneath the lift to perform service or maintenance – no matter how momentary that might be.

If the factory-provided maintenance device is damaged or missing, stop immediately and consult the factory for assistance. The manufacturer is not liable for your failure to use the approved maintenance device(s) and procedures that have been provided.

1. Any load must be removed from the lift prior to engaging the maintenance device(s). These devices are designed to support an unloaded lift only. Failure to remove the load from the lift prior to blocking could cause the failure of the maintenance device(s) and allow the lift to fall unexpectedly. This can result in personal injury or death, or permanent damage to the maintenance device(s) and/or the lift.
2. Raise the lift to its fully raised position. If you do not, the maintenance device(s) may not be able to be placed properly in its/their designed blocking position.
3. Remove the maintenance device(s) from its/their storage location and place it/them into the engaged position as shown in Figure 1. (Note: further information may be useful here to provide additional instructions as to the location and method of storage and engaged positions).
4. Lower the lift until it makes complete contact with the maintenance device(s). Re-check to ensure that all provided devices are fully and securely engaged. If the device(s) is/are not fully engaged the lift could fall unexpectedly, resulting in permanent damage to the device(s) or the lift.

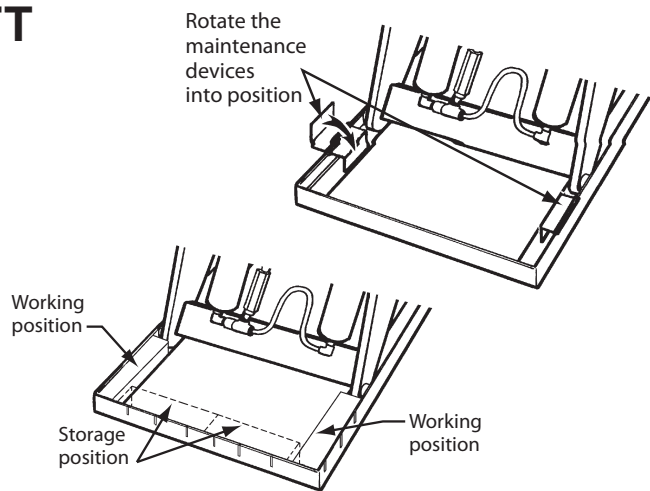

Figure 1 – Safe Servicing of Lift

⚠️ DANGER

If for any reason you are unable to lower the lift completely onto the maintenance device(s), stop immediately and consult the factory. Failure to properly use the factory approved maintenance device(s) could result in severe injury or death.

5. (For single-acting hydraulic, and pneumatic lifts) Once the maintenance device(s) is/are properly and securely engaged, continue to press the down button, valve or switch for an additional 5-10 seconds to relieve all pressure in the operating system (add more specifics here as required for pneumatic lifts).

⚠️ WARNING

Failure to relieve operating system pressure could result in the sudden and unexpected release of high pressure fluids (or air) during maintenance and/or repair of the lift and result in severe injury or death.

6. Follow OSHA electrical lock-out/tag-out procedures. Disconnect and tag all electrical and/or other power sources to prevent an unplanned or unexpected actuation of the lift.
7. Once inspection or work is complete, reverse the performance of the steps above to raise the lift off the maintenance device(s) and place the device(s) back into its/their designated storage position(s).

⚠️ DANGER

HIGH VOLTAGE ! – Disconnect and/or lock out the electrical supply to the power unit prior to any installation or maintenance being performed.

INSTALLATION & OPERATING INSTRUCTIONS

1. Before you start to install the machine, check for local codes and ordinances, which may apply in your area. It is your responsibility to obtain any necessary permits.
2. Read all of these installation instructions carefully. Be sure to read and understand all of the warnings!
3. If the hydraulic power unit will be mounted away from the machine, the power unit should be sheltered from the weather. It should be mounted within 30 feet of the machine to minimize the pressure drop in the hydraulic system. Be sure the hydraulic lines have been installed properly.

WARNING

Protect the hydraulic power unit from rain or moisture. If the electrical parts in the power unit get wet, workers may be hurt by electrical shock or the electrical parts may fail.

WARNING

The electric motor in the lift can create sparks. Do not install the hydraulic power unit in an area where flammable gases may be present.

POSITIONING THE LIFT

1. Remove the shipping material and unskid the machine.
2. Move the machine into position, supporting the base frame of the machine. Mount the machine on a firm level surface, if necessary, insert shims to level the machine. Install lag bolts to hold the machine in place. **Make sure to shim or grout under the base frame to prevent any flexing.**

WARNING

If the machine is mounted on an unstable surface, it may tip over when in use. You may be hurt, and the machine or the load may be damaged.

HYDRAULIC CONNECTIONS

(External Power Units Only.)

1. Install the power unit. Install the hydraulic line between the power unit and the lift as shown on the pit plan.
2. Blow out the hydraulic line with compressed air before connecting it to the power unit. Replace the solid plug on the hydraulic fluid tank with the vented plug supplied, then attach the vent line to the vented plug.

WARNING

Be sure that the hydraulic line will not be pinched by the lift as it raises or lowers. If you allow the line to be pinched, the lift may not work properly. A hose may break, the lift table may drop suddenly, and someone may be hurt.

NOTICE

It is very important to keep the hydraulic oil free of dirt, dust, metal chips, water, and other contamination. Most of the problems with hydraulic systems are caused by contamination in the oil. Be sure to flush all hydraulic lines before connecting remote power units.

NOTICE

If you do not install the vented plug in the tank, the pump may be damaged.

Table 1 – Hydraulic Oil Specifications

If the lift will be used at normal ambient temperatures, Southworth supplies the unit with Conoco AW 32 oil. This may be replaced by any other good quality oil with 150 SSU at 100° F and rust and oxidation inhibitors and anti-wear properties.

If the lift will be used at ambient temperatures below 0°F, use aircraft hydraulic oil. Use Type 15 aircraft hydraulic oil.

The following are equivalent to CONOCO 32:

TYPE	MANUFACTURER
DTE 24	EXXON/MOBIL
NUTO H32	EXXON/MOBIL
AMOCO AW32	CHEVRON (AMOCO CO.)
AW32.....	CITGO

ELECTRICAL CONNECTIONS

⚠ DANGER

The lift may use a power supply of up to 460 Volt AC. This voltage can kill you. Do not work with the electrical parts unless you are a qualified electrician.

1. A machine with a 115 Volt power unit needs to have a designated outlet and breaker of at least 20 AMP.
2. A machine designed for three phase AC, you must be sure the pump and motor is turning in the right direction. The machine should start to move quickly when you press the up or down button. If the machine does not move in 2 or 3 seconds, do not try to operate the machine! Exchange any two of the three phase leads. If this does not correct the problem, please contact Southworth 's Customer Service Department.

TESTING

1. Check the level of the hydraulic oil. With the machine in the lowered position the tank should be full, add oil if necessary.
2. Clear the area around the machine. Remove any loose wires, lumber or other material that might get in the way of the machine as it is in use.

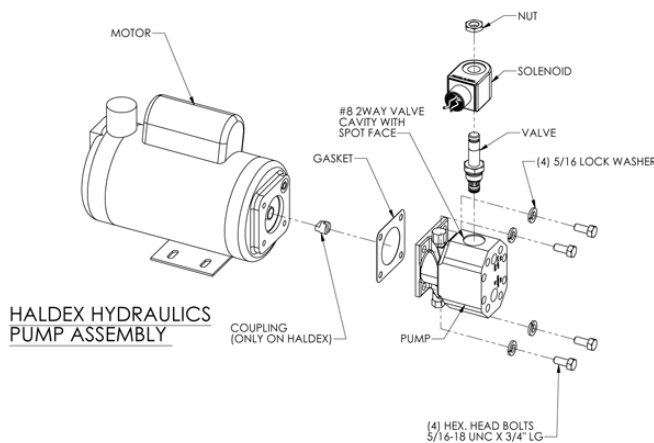

Pre 8/22/2012

Figure 2 – Hydraulic Pump and Down Valve

3. Operate the machine through its full range of travel. The machine should rise smoothly with a quiet humming sound and lower smoothly and quietly. Raise and lower the lift a few times to check the clearances around the lift table.

⚠ WARNING

As the machine moves, “pinch points” are created. If you are standing too close to the machine when it is moving, your arm or leg may be caught in the moving parts and you may be hurt. Stay away from the pinch points when the lift is moving.

COMPLETING INSTALLATION

1. Test the machine with the rated load. If the machine does not move and you hear a loud squealing noise, this means the pressure relief valve is operating. Contact Southworth for instructions.

⚠ WARNING

Do not continue to use the machine if this happens. The pump will overheat very quickly and may be permanently damaged. Do not try to adjust the relief valve. You may overwork the machine. This can cause the machine to fail suddenly and you may be hurt.

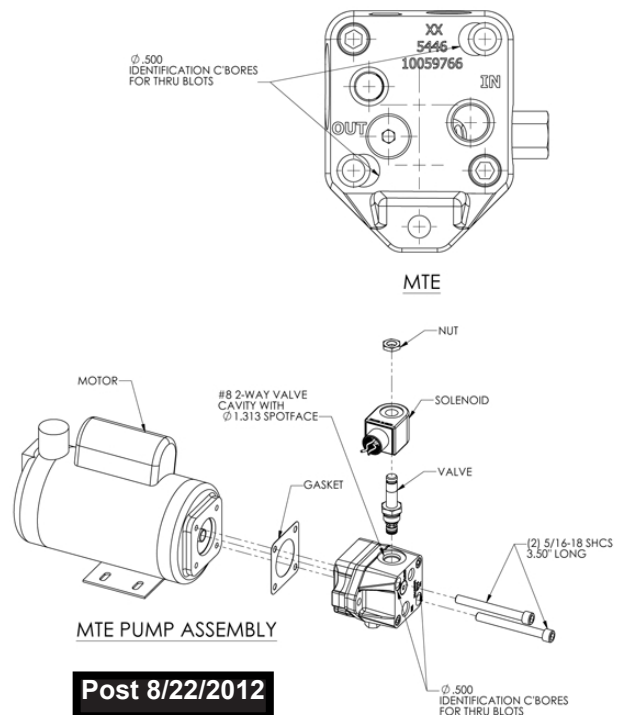

Post 8/22/2012

SAFETY ALERT SYMBOLS AND SIGNAL WORDS

The safety of all persons operating, maintaining, repairing, or in the vicinity of this equipment is of paramount concern. This is a powerful machine with moving parts, and is capable of causing personal injury if proper precautions are not taken. Therefore, throughout this manual, certain hazards have been identified which may occur in the use of the machine, and there are appropriate instructions or precautions which should be taken to avoid these hazards. In some cases, there are consequences which may occur if instructions or precautions are not followed. Below are the symbols and signal words along with their definitions referenced from ANSI Z535.4 - Product Safety Signs and Labels.

Safety Alert Symbols

These are the safety alert symbols.. They are used to alert you to potential physical injury hazards. Obey all safety messages that follow this symbol to avoid possible injury or death.



For use with **DANGER** signal word
(Red Background)



For use with **WARNING** signal word
(Orange Background)



For use with **CAUTION** signal word
(Yellow Background)

Signal Words

The meaning of different signal words as defined by ANSI Standard Z535.4 indicates the relative seriousness of the hazardous situation.



(Red Background)

DANGER indicates a hazardous situation which, if not avoided, will result in death or serious injury.



(Orange Background)

WARNING indicates a hazardous situation which, if not avoided, could result in death or serious injury.



(Yellow Background)

CAUTION, used with the safety alert symbol, indicates a hazardous situation which, if not avoided, could result in minor or moderate injury.



(Blue Background)

NOTICE is used to address practices not related to personal injury.



(Green Background)

SAFETY INSTRUCTIONS (or equivalent) signs indicate safety-related instructions or procedures.

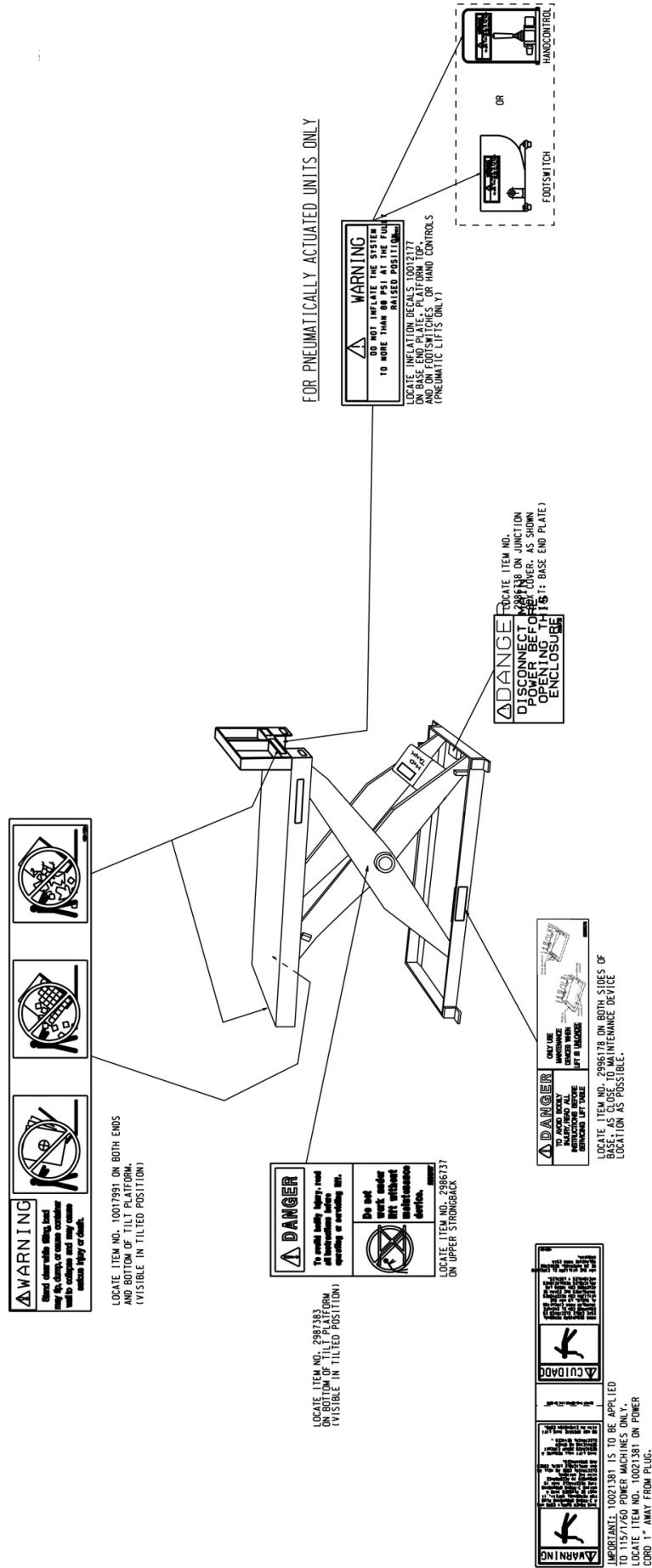

Figure 3 – Labels and Precautionary Markings

MAINTENANCE

All service should be done by qualified personnel. Qualified personnel should be able to read and understand wiring and hydraulic diagrams. They should be able to troubleshoot live electrical circuits safely and in accordance with accepted practice.

FOR SAFETY'S SAKE, if in doubt, please contact your dealer of Southworth Products Corporation Customer Service Department at (207)878-0700 or (800)743-1000.

Before servicing the lift, read and understand this entire section and the section entitled "Operating Instructions."

HAZARDS

There are several hazards you should be aware of as you service the lift:

Before working on the machine be sure to insert any and all maintenance devices.

DANGER

The machine may use a power supply of up to 575 Volts. This voltage can kill you. Do not work with the electrical parts unless you are a qualified electrician.

WARNING

As the machine moves, "pinch points" are created. Keep hands, feet and loose clothing away from these pinch points. If your arms, hands or your clothing is caught, you may be hurt.

WARNING

Do not change the setting on the relief valve in the pump. If you do, this may damage the machine and you may be hurt. The relief valve has been included for the protection of all of the workers who use the machine.

WARNING

Before working on the machine, be sure to release pressure on the hydraulic system.

CAUTION

The warning labels on the machine are there for the safety of the operator. If the labels are worn or missing, replace them.

ROUTINE PERIODIC MAINTENANCE

Every month:

1. Visually inspect the center pivot bushing and pins, cylinder clevis pins and bushings. Apply oil or WD-40 to all parts listed above.

Note: Although the bearings are "lifetime lubricated" their performance may be extended by additional periodic lubrication (WD-40).

2. Check the level and appearance of the hydraulic fluid. With the machine in the lowered position, there should be about $\frac{3}{4}$ of an inch of air space in the tank or with the machine fully elevated, there should be about $\frac{3}{4}$ of an inch of oil left in the tank. Use a dipstick to check the oil level and add oil if necessary. Change the oil if it has darkened from its original color, turned milky white or if it feels gritty or sticky.

CAUTION

It is important to use hydraulic fluid with the correct grade and properties. The hydraulic fluid the machine is provided with is Texaco Rando HD-32

Every six months:

1. Check all of the hydraulic fittings and hoses and repair the connections if necessary. Occasionally, the fittings can be worked loose by vibrations from the machine.

WARNING

If a hydraulic fitting becomes loose or if a hydraulic hose breaks, the hydraulic fluid will escape from the system under pressure. If the machine is elevated when this happens, it will drop very quickly. Someone may be hurt or the product or the machine may be damaged.

2. Remove the down valve from the pump and the solenoid. Disassemble and clean using compressed air. Reassemble and reinstall.

3. Drain all of the hydraulic fluid from the tank and cylinders and discard it.

4. Remove the suction filter from the tank. Clean by using compressed air. Reinstall and tighten all fittings.

5. Refill the tank with new hydraulic fluid.

Maintenance for machines with high cycle package:

1. Every 10,000 cycles or every month, visually inspect the entire lift. Replace all worn or broken parts. Change the hydraulic fluid. Lubricate all pivot points and clean the roller tracks.
2. Every 30,000 cycles or every three months, visually inspect the entire lift. Check the motor starter contacts and limit switch. Clean and lubricate all pivot points. Replace all worn or broken parts. Replace all hydraulic filters and change the hydraulic fluid.

Maintenance for units with Air Motors:

On this type of unit, the air motor is used to power the hydraulic pump (see figure 1). When the lift is raised, a valve sends compressed air to the air motor. The air motor powers the pump and provides hydraulic power for the unit. When the lift is lowered, an air operated down valve allows the hydraulic fluid to escape from the cylinders.

The vanes in the rotary type air motor take up their own wear and will last 5,000 to 15,000 hours of operation. (The actual service lift depends on the operating speed, method of oiling, operating pressure, and the precautions taken in maintaining the machine.) The type of shaft seal used will not withstand pressures of more than 100 psi.

An automatic airline lubricator must be installed in the airline just ahead of the motor. (The filter, regulator,

and lubricator are not supplied by Southworth.) The lubricator must be adjusted to feed on drop of oil for every 50 to 75 cfm of air going through the motor. This lubrication is necessary to reduce friction on all internal moving parts and to prevent rust.

The starting torque of the air motor is greater than the running torque. This could vary depending on the position at which the vanes stop in relation to the air intake port. It is advisable to use a pressure regulator or a simple shut off valve to obtain the desired power, speed, and torque; and to conserve air.



Do not allow the air motor to "run free" at high speed with no load. This can cause buildup of excessive heat and loss of internal clearances and can damage the motor quickly.

If the motor is sluggish or inefficient, try flushing it with solvent. To flush a motor, disconnect the airline and muffler. Add several teaspoons of solvent directly into the motor. (Southworth recommends the following solvents for this purpose: Gast Flushing Solvent AH255, Dem Kote 2X726 and Loctite Safety Solvent.) Rotate the shafts by hand in both directions for a few minutes. Reconnect the airline and gradually increase the air pressure and flow until there is no trace of the solvent in the exhaust air. Re-lubricate the motor with a squirt of oil in the chamber.

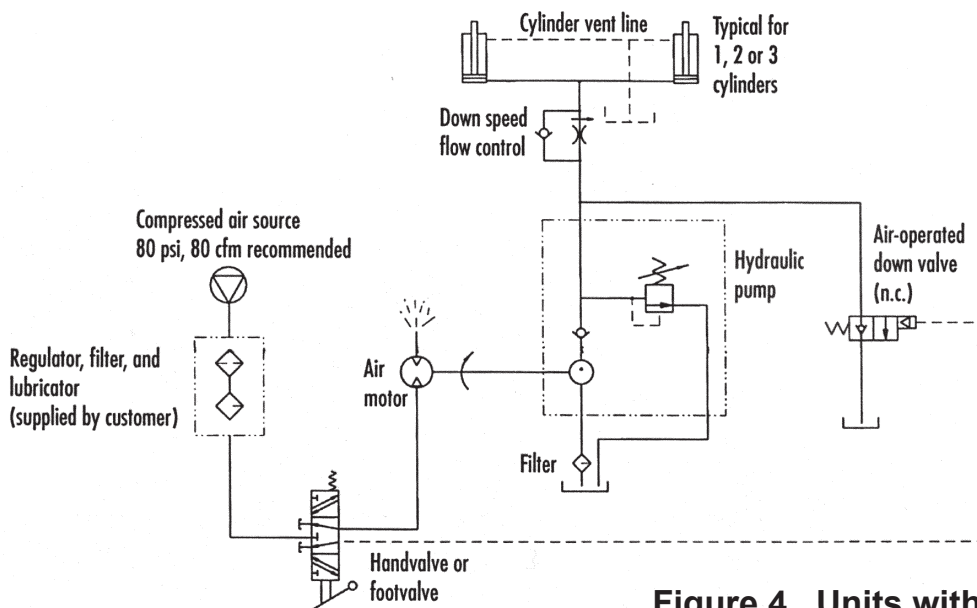

Figure 4. Units with Air Motors

TROUBLESHOOTING

PROBLEM	POSSIBLE CAUSE	CHECK THIS
Lift will not raise	Weight of load too heavy	Check the actual weight of the load
	Motor not running	Check the main disconnect switch, fuses, and wiring to the motor. A 20 amp, designated braker must be supplied for 110V
	Hydraulic oil level low	When lift is raised as far as possible, oil level should be 3/4" from bottom of tank. When lift is down, 3/4" from top
	Lift has reached its upper limit	Upper limit switch may need to be adjusted
	Motor may be "single phasing"	If motor hums but does not turn, check motor wiring and line fuses.
	Motor voltage too low	Supply voltage should be +/- 10% of the rating at the motor terminals.
	Tank vent plugged	If supplied, remove solid plug from tank, insert vent plug.
	Suction filter clogged	Clean suction filter as described in periodic maintenance
	Vacuum leak in suction line	Check all fittings in suction line
	Down valve may be energized	Check wiring to down valve, and solenoid in the valve
	Missing coupling	Check to insure the coupling has been installed between the pump and motor
The lift fails to hold	Down valve may be leaking	Remove down valve and inspect for debris which may be preventing it from closing.
	Down valve may be energized	Check the solenoid in the valve with a volt meter.
	Cylinder may be leaking	Check for oil in cylinder in the vent line.
Lift will not lower	Down valve may be de-energized	Check the solenoid in the valve with a volt meter
	Flow control needs adjustment	Adjust flow control as needed
Lift raises too slowly	Voltage may be low	Check voltage at motor to ensure proper voltage is being supplied
	Foreign material clogging suction filter, breather cap or pressure line	Remove necessary components and clean
	Pump may be overheating due to insufficient oil	Check oil level and oil viscosity
Lift lowers too slowly	Down valve may not be fully open or stuck closed	Remove down valve and clean
	Flow control may need adjustment	Adjust flow control as needed

If the steps listed above do not solve the problem, please call the Southworth's Customer Service Department

TROUBLESHOOTING WARNINGS

All servicing should be done by qualified personnel. Qualified personnel should be able to read and understand wiring and hydraulic diagrams. They should be able to troubleshoot live electrical circuits safely and in accordance with accepted practice. **For safety's sake**, if in doubt, please contact your dealer or Southworth Products Corp.

Before servicing the lift, **read and understand this entire section and the section entitled "Operating Instructions."**

WARNING

Before working underneath the lift, always raise the lift and insert the maintenance devices, as shown in Figure 1. Failure to do so may result in damage to the lift and severe personal injury!

If the lift will not raise:

CAUTION

Do not continue to hold the "up" button for more than 2 or 3 seconds. You may damage the pump.

WARNING

Do not change the relief valve setting. This valve has been included for the protection of workers who install, use, or service the lift. If it is ever necessary to repair or reset the valve, contact Southworth Products Corp. for instructions.

WARNING

Do not disconnect the up limit switch. Instead, loosen the adjusting screw, and change the position of the arm. If you do disconnect the switch, when the lift platform moves up, it may not stop at the correct point. If the platform rises above the normal stopping point, the frame of the unit may be damaged. People working nearby may be hurt.

CAUTION

If cavitation is allowed to continue, the pump may be damaged, and may have to be replaced.

If the lift elevates, but fails to hold a load:

WARNING

Failure to insert the maintenance devices may result in damage to the lift and severe personal injury!

If the lift fails to lower:

WARNING

Failure to insert the maintenance devices may result in damage to the lift and severe personal injury!

DANGER

Do not try to adjust the flow control while pressing the "down" button. If you try this, the lift table may drop suddenly, and you may be hurt.

ORDERING REPLACEMENT PARTS

Southworth has carefully chosen the components in your unit to be the best available for the purpose. Replacement parts should be identical to the original equipment. **Southworth will not be responsible for equipment failures resulting from the use of incorrect replacement parts or from unauthorized modifications to the machine.**

Southworth can supply all replacement parts for your Southworth lift. We have identified key replacement parts for your lift. With your order, please include the model number and the serial number of the unit. You will find these numbers on the name plate.

To order replacement parts, please call the Parts Department at (207) 878-0700. Parts are shipped subject to the following terms:

- FOB factory.
- Returns only with the approval of our parts department.
- Payment net 30 days (except parts covered by warranty).
- Freight collect (except parts covered by warranty).
- The warranty for repair parts is 30 days from date of shipment.

Parts replaced under warranty are on a "charge-credit" basis. We will invoice you when we ship the replacement part, then credit you when you return the worn or damaged part, and we verify that it is covered by our warranty. Labor is not covered under warranty for Parts orders.

Parts Department
Southworth Products Corp
P.O. Box 1380
Portland, ME 04104-1380
Telephone: (207) 878-0700
FAX: (207) 797-4734
repairparts@SouthworthProducts.com

FIGURES & DIAGRAMS

***PART I:
SINGLE ACTING TILTER***

OPERATING AND MAINTENANCE MANUAL

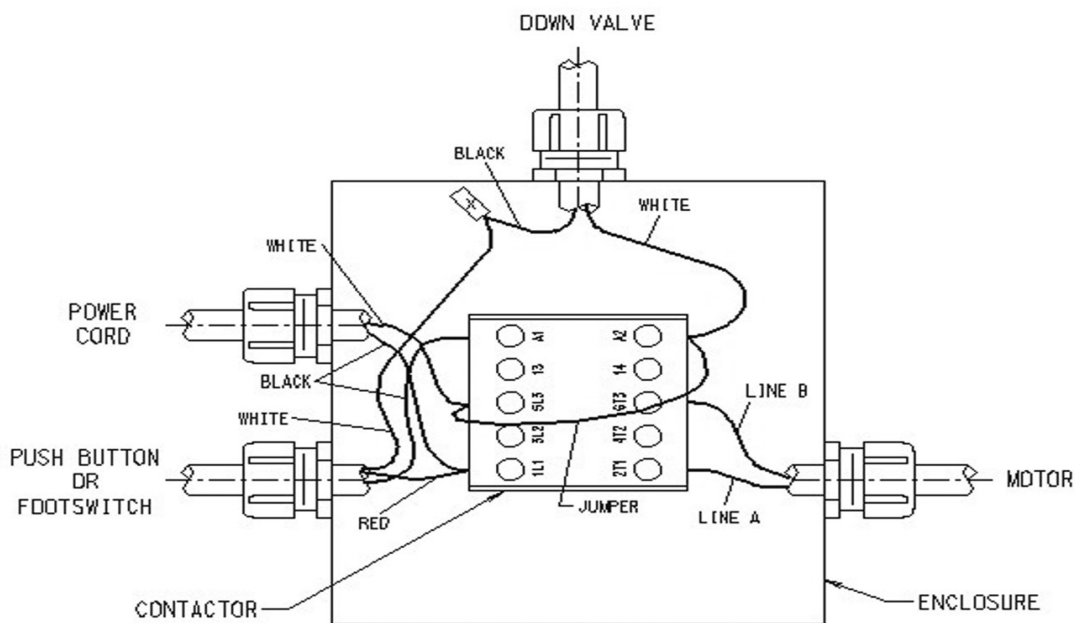
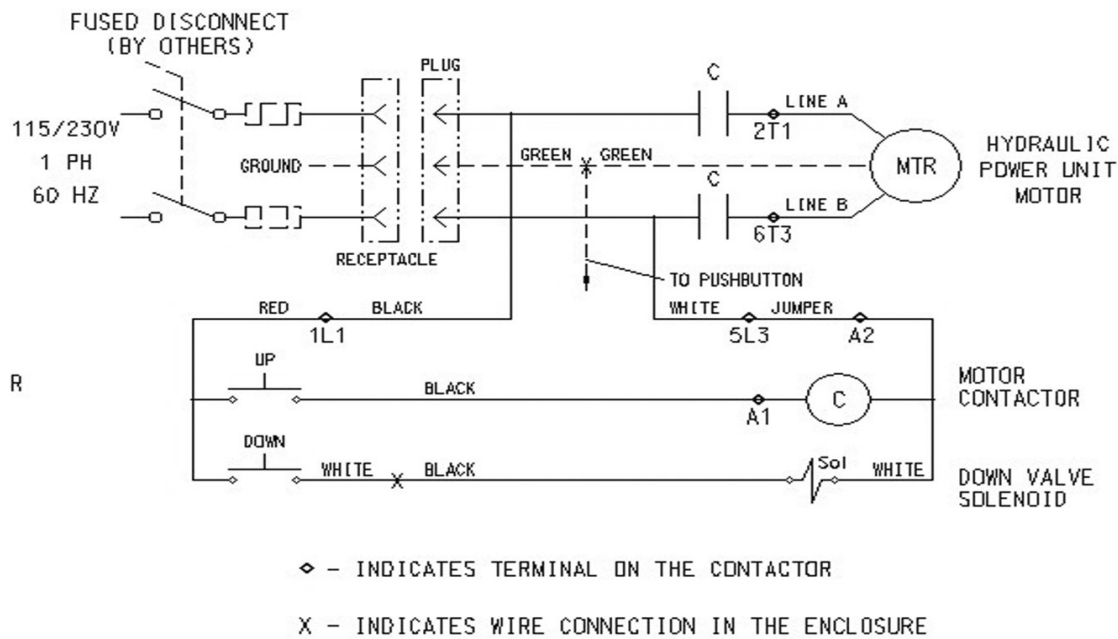

NOTE:
- ENTRY LOCATIONS MAY DIFFER FROM THOSE SHOWN.
- GROUND CONNECTIONS, ALTHOUGH NOT SHOWN, ARE REQUIRED.

- REFERENCE:
B-3032834 STANDARD 1 PHASE
B-3032835 WITH UP LIMIT
B-3039865 WITH DOWN LIMIT
B-3032836 WITH UP/DOWN LIMITS
B-60012199 WITH INTERMEDIATE UP (N.O. HELD CLOSED)
B-3060340 WITH UP PROXIMITY (N.C.)
B-60003103 WITH UP PROXIMITY (N.O.)
B-3034986 WITH TURNTABLE LIMIT
B-3058886 WITH UP LIMIT & TURNTABLE LIMIT
B-3031360 WITH MOTORSTARTER & O.L.
B-3060468 WITH CONTROLS BY OTHERS & NO LIMITS
B-3042174 WITH CONTROLS BY OTHERS & UP/DOWN LIMITS
B-3062437 FOR MAINTAINED UP WITH UP LIMIT
B-3060356 FOR MAINTAINED DOWN WITH DOWN LIMIT
B-3045005 FOR MAINTAINED UP/DOWN (N.C. UP/DN LIMITS)
B-60006251 FOR MAINTAINED UP/DOWN (N.O. UP / N.C. DN LIMITS)
B-3038842 FOR DOUBLE-ACTING WITH UP/DN LIMITS

Figure 5. Electrical connections for Single Phase AC

WIRING DIAGRAM

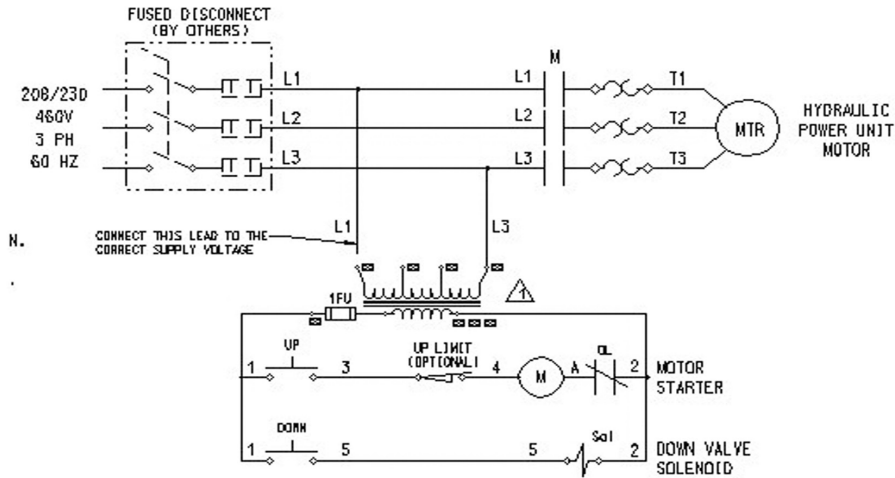

NOTE: UPPER TRAVEL LIMIT SWITCH IS OPTIONAL.
IF LIMIT SWITCH IS ABSENT, MOVE WIRE 4
IN PANEL FROM TERMINAL 4 TO TERMINAL 3
AND RENUMBER AS WIRE 3.

CONTROL PANEL

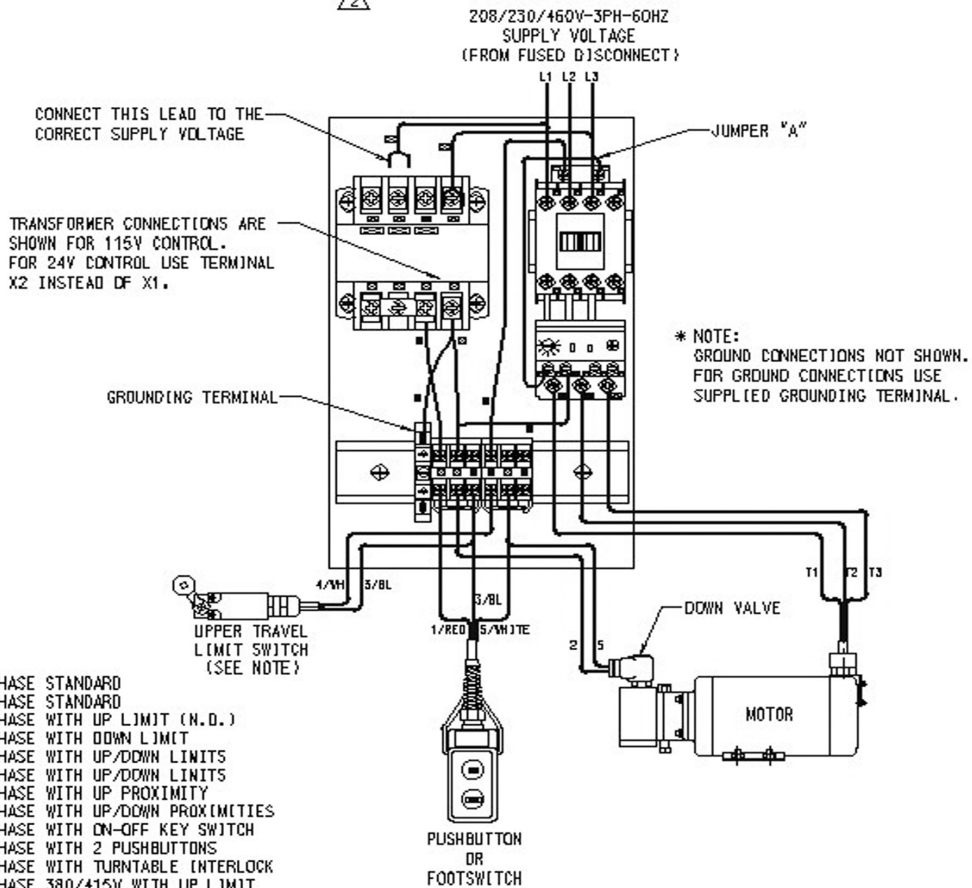

REFERENCE:

B-3040491	3	PHASE STANDARD
B-3040492	1	PHASE STANDARD
B-60011651	3	PHASE WITH UP LIMIT (N.D.)
B-3046011	3	PHASE WITH DOWN LIMIT
B-3041700	3	PHASE WITH UP/DOWN LIMITS
B-60009265	1	PHASE WITH UP/DOWN LIMITS
B-3052502	3	PHASE WITH UP PROXIMITY
B-60004901	3	PHASE WITH UP/DOWN PROXIMITIES
B-3043763	3	PHASE WITH ON-OFF KEY SWITCH
B-3035003	3	PHASE WITH 2 PUSHBUTTONS
A-3025366	3	PHASE WITH TURNTABLE INTERLOCK
B-3049481	3	PHASE 380/415V WITH UP LIMIT
B-3041740	3	PHASE 575/600V WITH UP LIMIT
B-3045661	3	PHASE 575/600V WITH UP/DOWN LIMITS
B-3003755	3	PHASE WITH PRIMARY FUSES
B-3041753	3	PHASE WITH FUSED DISCONNECT
B-3045046	3	PHASE WITH MAINTAINED UP
B-3045151	3	PHASE WITH MAINTAINED DOWN
B-3057068	3	PHASE WITH MAINTAINED UP/DOWN
C-3051986	3	PHASE WITH REMOTE RADIO CONTROL
B-3039373	3	PHASE WITH CONTROLS BY OTHERS & UP LIMIT
B-3051859	3	PHASE WITH CONTROLS BY OTHERS & UP/DOWN LIMITS

Figure 6. Electrical connections for Three Phase AC

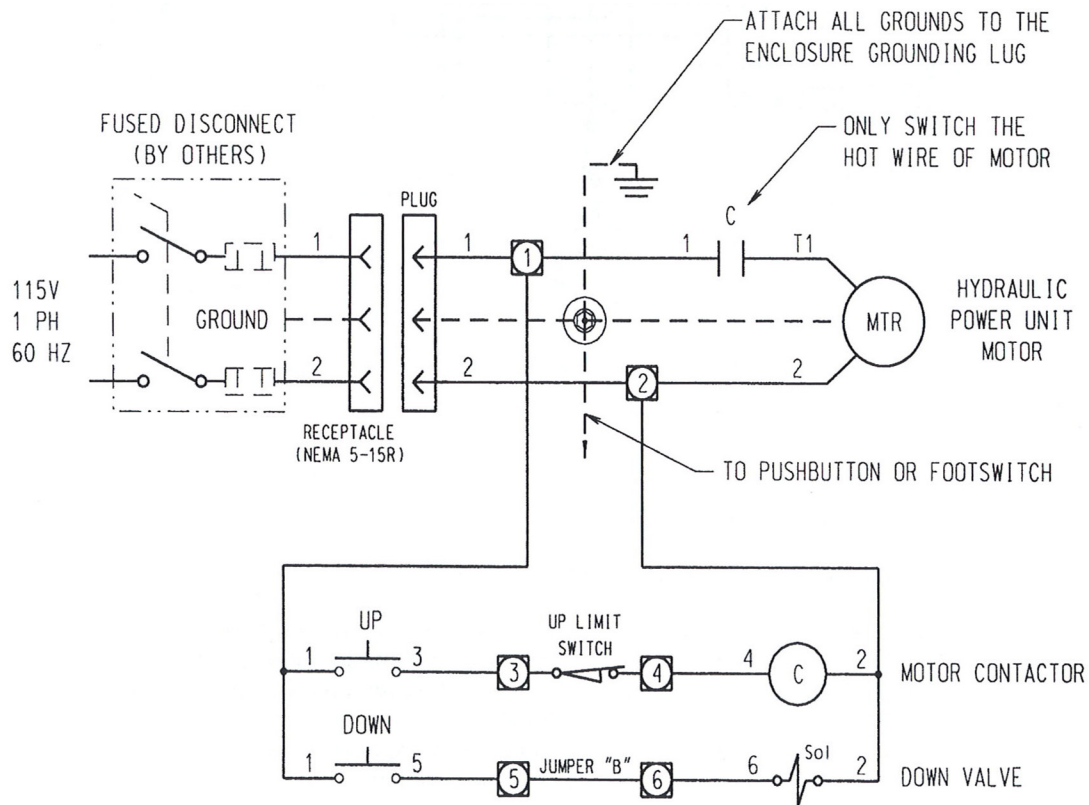

Figure 7. Electrical connections for Single Phase AC

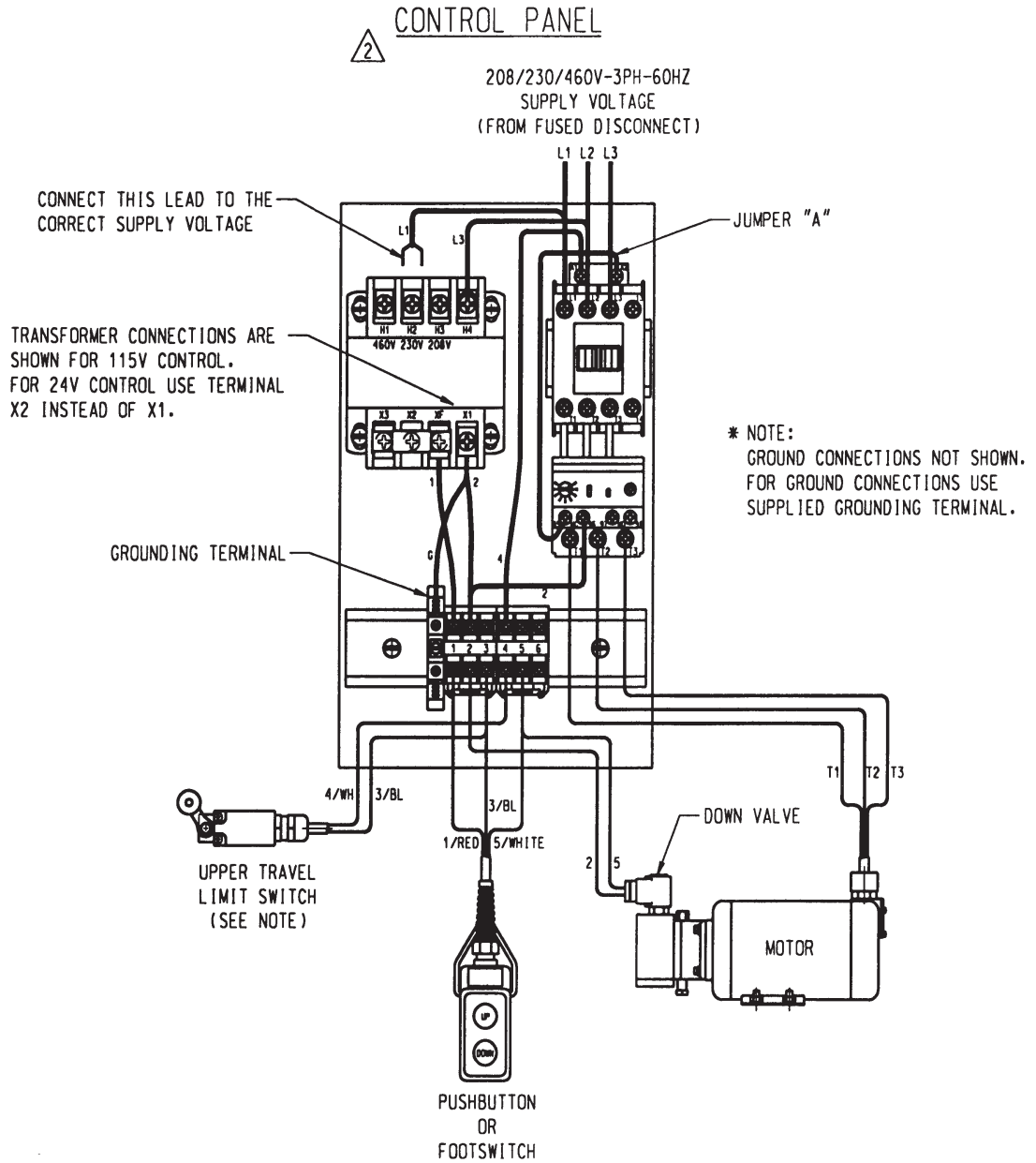

Figure 8. Electrical connections for Three Phase AC

FIGURES & DIAGRAMS

PART II: DOUBLE ACTING TILTER

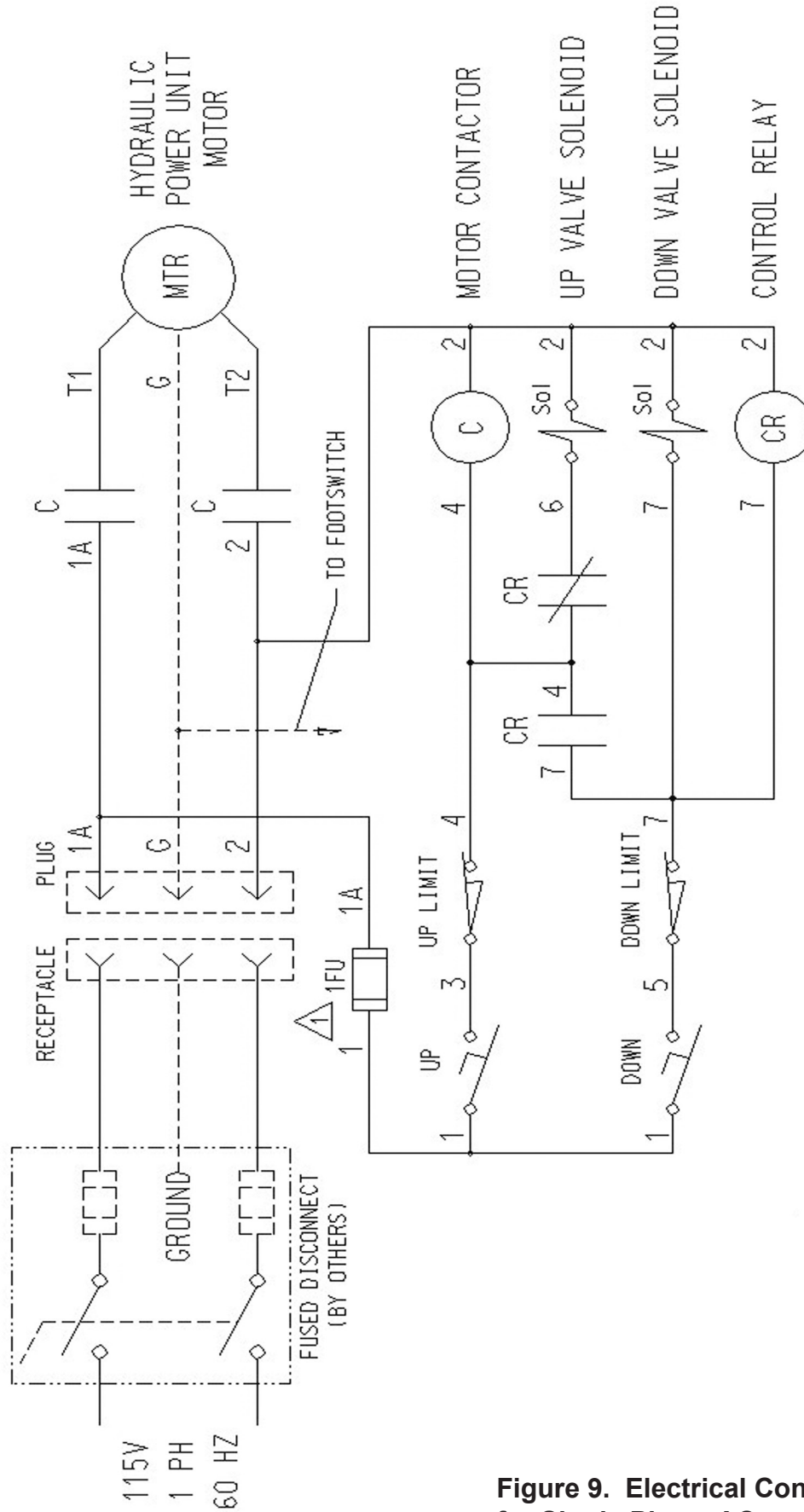
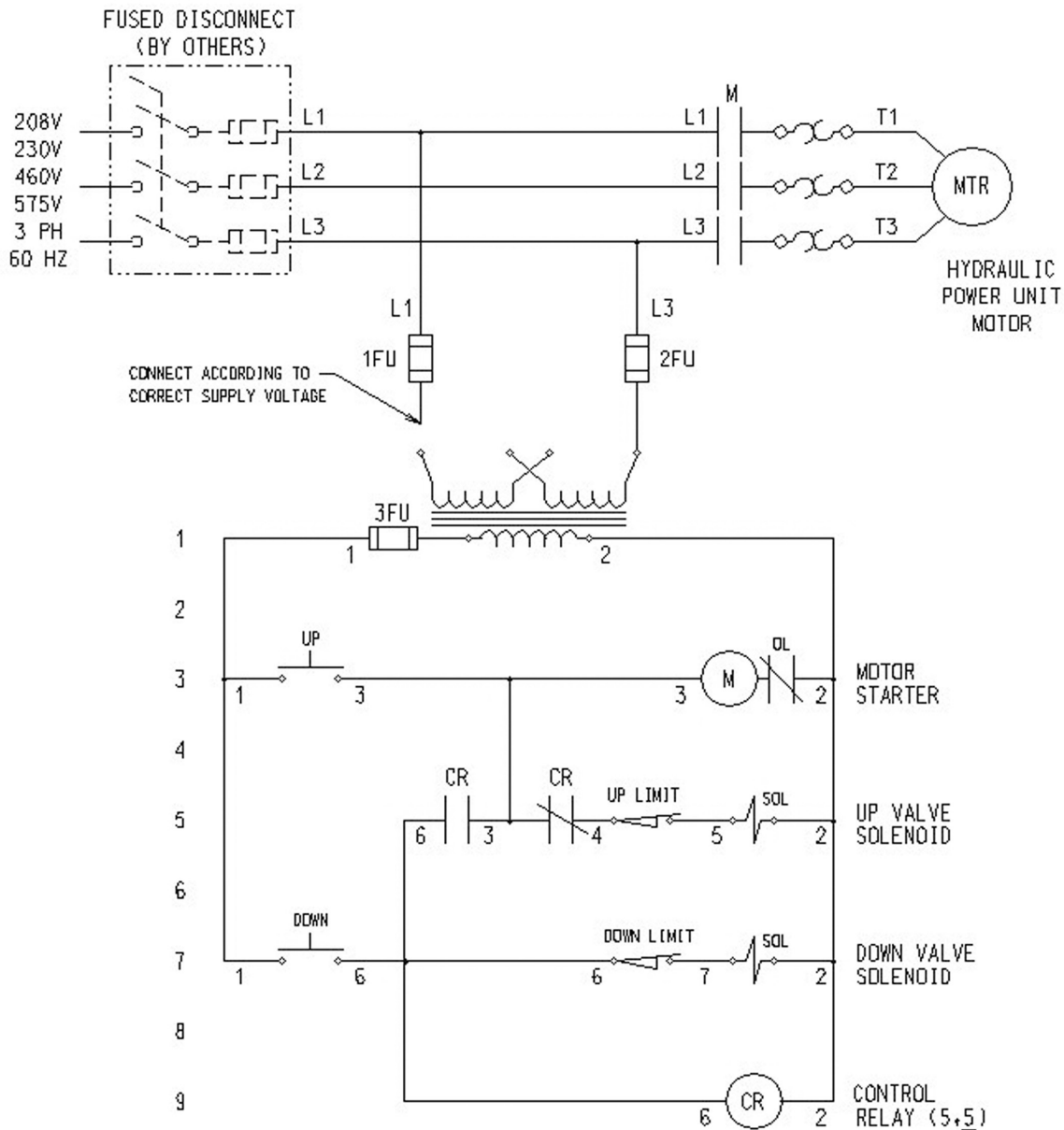

Figure 9. Electrical Connections for Single Phase AC

OPERATING AND MAINTENANCE MANUAL



THE FOLLOWING WIRING DIAGRAMS CAN BE USED FOR MACHINES WITH NO COAST/NO DRIFT VALVING OR DOUBLE-ACTING CYLINDERS.

- SEE B-3046184 FOR 3 PHASE, RELAY, NO LIMITS
- SEE B-3048T01 FOR 3 PHASE, RELAY, UP LIMIT
- SEE B-3032618 FOR 3 PHASE, RELAY, UP/DOWN LIMITS
- SEE B-3062462 FOR 3 PHASE, RELAY, NO LIMITS, CONTROLS BY OTHERS
- SEE A-3046872 FOR 115-1-60, RELAY, UP/DOWN LIMITS
- SEE B-3048376 FOR 230-1-60, RELAY, UP/DOWN LIMITS
- SEE B-3058794 FOR 3 PHASE, NO RELAY, NO LIMITS
- SEE B-3027603 FOR 3 PHASE, NO RELAY, UP LIMIT
- SEE B-3035961 FOR 3 PHASE, NO RELAY, UP/DOWN LIMITS
- SEE A-3051890 FOR 115V, NO RELAY, NO LIMITS
- SEE A-3042T25 FOR 115V, NO RELAY, UP LIMIT
- SEE A-3038032 FOR 115V, NO RELAY, UP/DOWN LIMITS
- SEE B-3058T83 FOR 3 PHASE, MAINTAINED OPERATION
- SEE B-3046897 FOR 1 PHASE, MAINTAINED OPERATION
- SEE B-3059199 FOR 3 PHASE, DEADMAN OPERATION w/E-STOP
- SEE B-3062159 FOR 3 PHASE, RELAY, LIMITS, SLOW-UP VALVE
- SEE B-60014267 FOR 3 PHASE, RELAY, LIMITS, DUAL SERIES CONTROLS
- SEE B-60014299 FOR 3 PHASE, RELAY, LIMITS, KEY ON/OFF

Figure 10. Electrical Connections for Three Phase AC

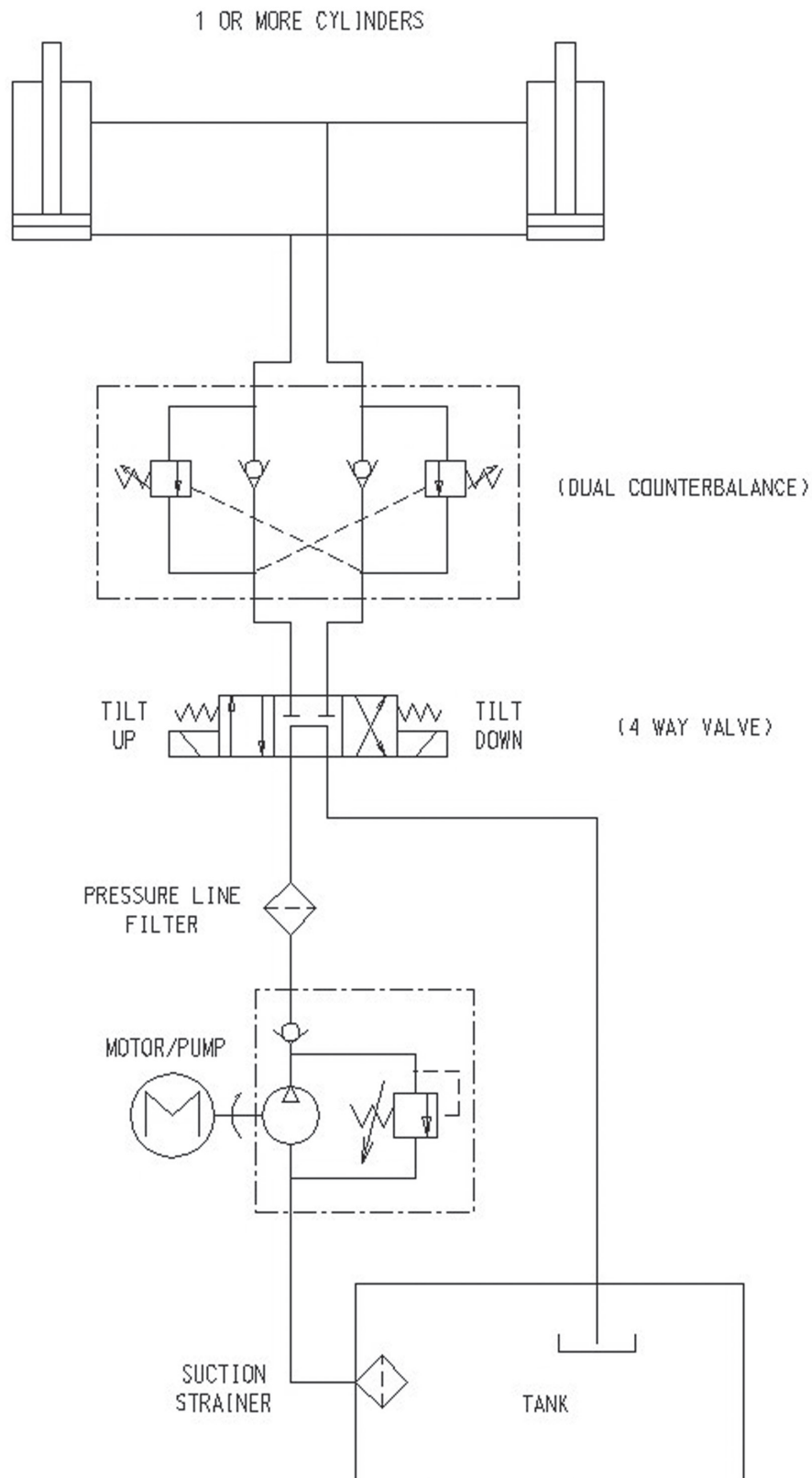

- REFERENCE:
- SEE B-3045535 FOR RETURN LINE FILTER
 - SEE B-3047820 FOR PRESSURE LINE FILTER
 - SEE B-3050024 FOR PRESSURE LINE FILTER & VELOCITY FUSES
 - SEE B-3055204 FOR PRESSURE LINE FILTER & (2) FLOW CONTROLS
 - SEE B-3060988 FOR RETURN LINE FILTER & (2) FLOW CONTROLS
 - SEE B-60003851 FOR RETURN LINE FILTER & (1) FLOW CONTROL
 - SEE B-3062158 FOR RETURN FILTER, FLOW CONTROLS, & SLOW-UP VALVE

Figure 11. Hydraulic Connections for Single Phase AC & Three Phase AC

FIGURES & DIAGRAMS

PART III: UPENDER

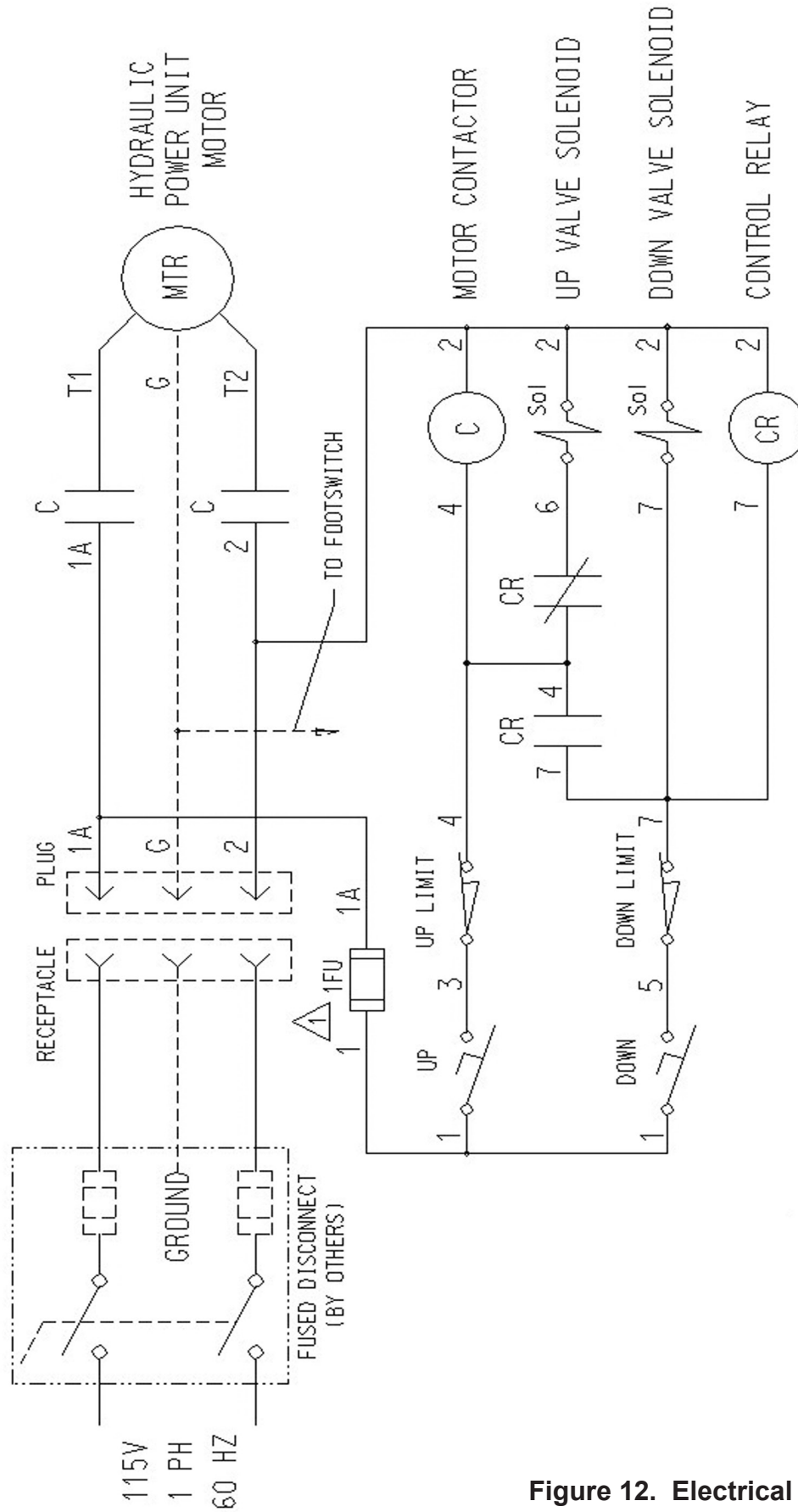
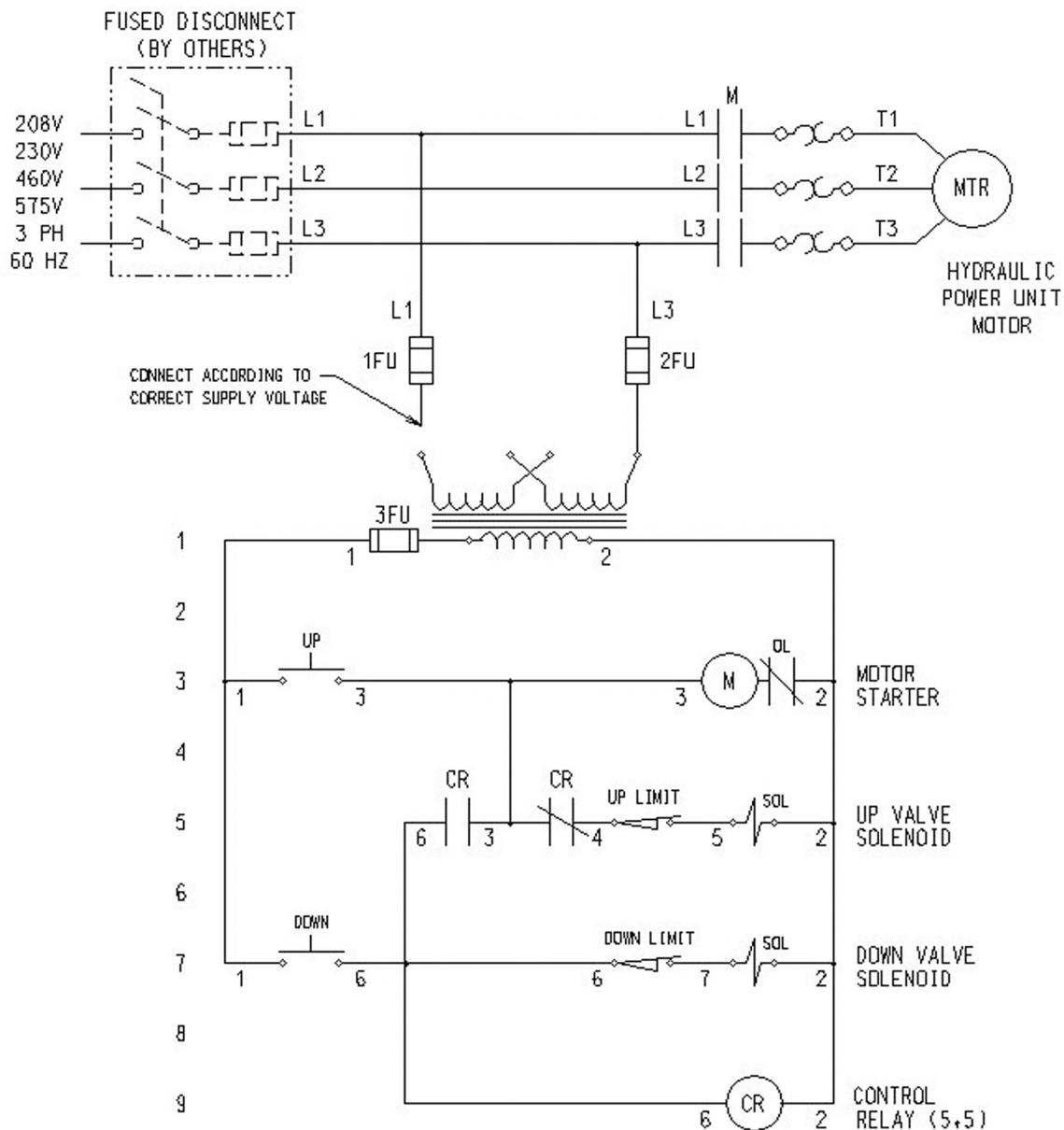

Figure 12. Electrical Connections for Single Phase AC

OPERATING AND MAINTENANCE MANUAL



THE FOLLOWING WIRING DIAGRAMS CAN BE USED FOR MACHINES WITH NO COAST/NO DRIFT VALVING OR DOUBLE-ACTING CYLINDERS.

- SEE B-3046184 FOR 3 PHASE, RELAY, NO LIMITS
- SEE B-3048T01 FOR 3 PHASE, RELAY, UP LIMIT
- SEE B-3032618 FOR 3 PHASE, RELAY, UP/DOWN LIMITS
- SEE B-3062462 FOR 3 PHASE, RELAY, NO LIMITS, CONTROLS BY OTHERS
- SEE A-3046872 FOR 115-1-60, RELAY, UP/DOWN LIMITS
- SEE B-3048376 FOR 230-1-60, RELAY, UP/DOWN LIMITS
- SEE B-3058794 FOR 3 PHASE, NO RELAY, NO LIMITS
- SEE B-3027603 FOR 3 PHASE, NO RELAY, UP LIMIT
- SEE B-3035961 FOR 3 PHASE, NO RELAY, UP/DOWN LIMITS
- SEE A-3051890 FOR 115V, NO RELAY, NO LIMITS
- SEE A-3042T25 FOR 115V, NO RELAY, UP LIMIT
- SEE A-3038032 FOR 115V, NO RELAY, UP/DOWN LIMITS
- SEE B-3058T83 FOR 3 PHASE, MAINTAINED OPERATION
- SEE B-3046897 FOR 1 PHASE, MAINTAINED OPERATION
- SEE B-3059199 FOR 3 PHASE, DEADMAN OPERATION w/E-STOP
- SEE B-3062159 FOR 3 PHASE, RELAY, LIMITS, SLOW-UP VALVE
- SEE B-60014267 FOR 3 PHASE, RELAY, LIMITS, DUAL SERIES CONTROLS
- SEE B-60014299 FOR 3 PHASE, RELAY, LIMITS, KEY ON/OFF

Figure 13. Electrical connections for Three Phase AC

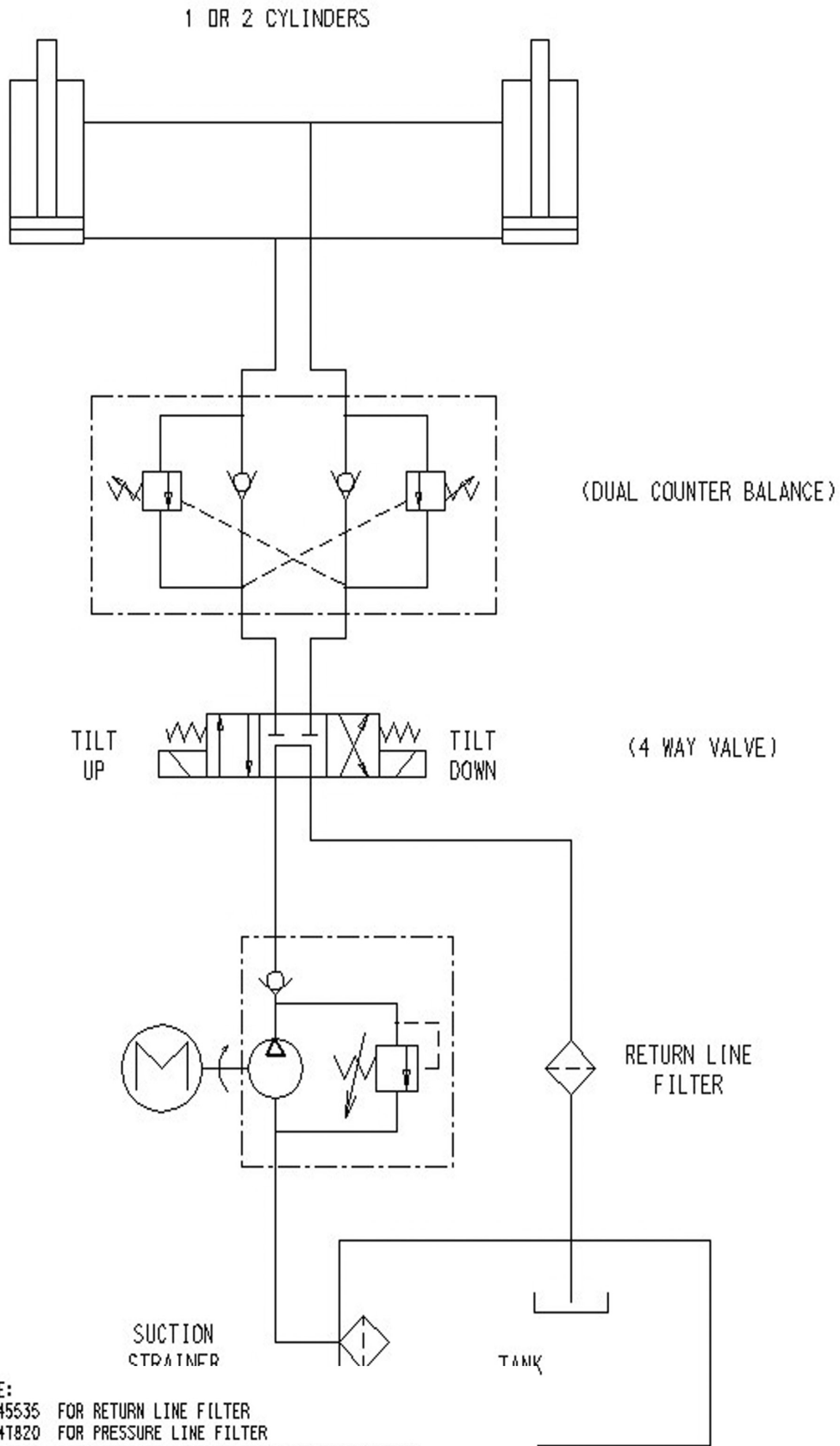

- REFERENCE:**
- SEE B-3045535 FOR RETURN LINE FILTER
 - SEE B-3047820 FOR PRESSURE LINE FILTER
 - SEE B-3050024 FOR PRESSURE LINE FILTER & VELOCITY FUSES
 - SEE B-3055204 FOR PRESSURE LINE FILTER & (2) FLOW CONTROLS
 - SEE B-3060908 FOR RETURN LINE FILTER & (2) FLOW CONTROLS
 - SEE B-60003051 FOR RETURN LINE FILTER & (1) FLOW CONTROL
 - SEE B-3062150 FOR RETURN FILTER, FLOW CONTROLS, & SLOW-UP VALVE

Figure 14. Hydraulic schematic for Single Phase AC & Three Phase AC

FIGURES & DIAGRAMS

PART IV: LIFT / TILT

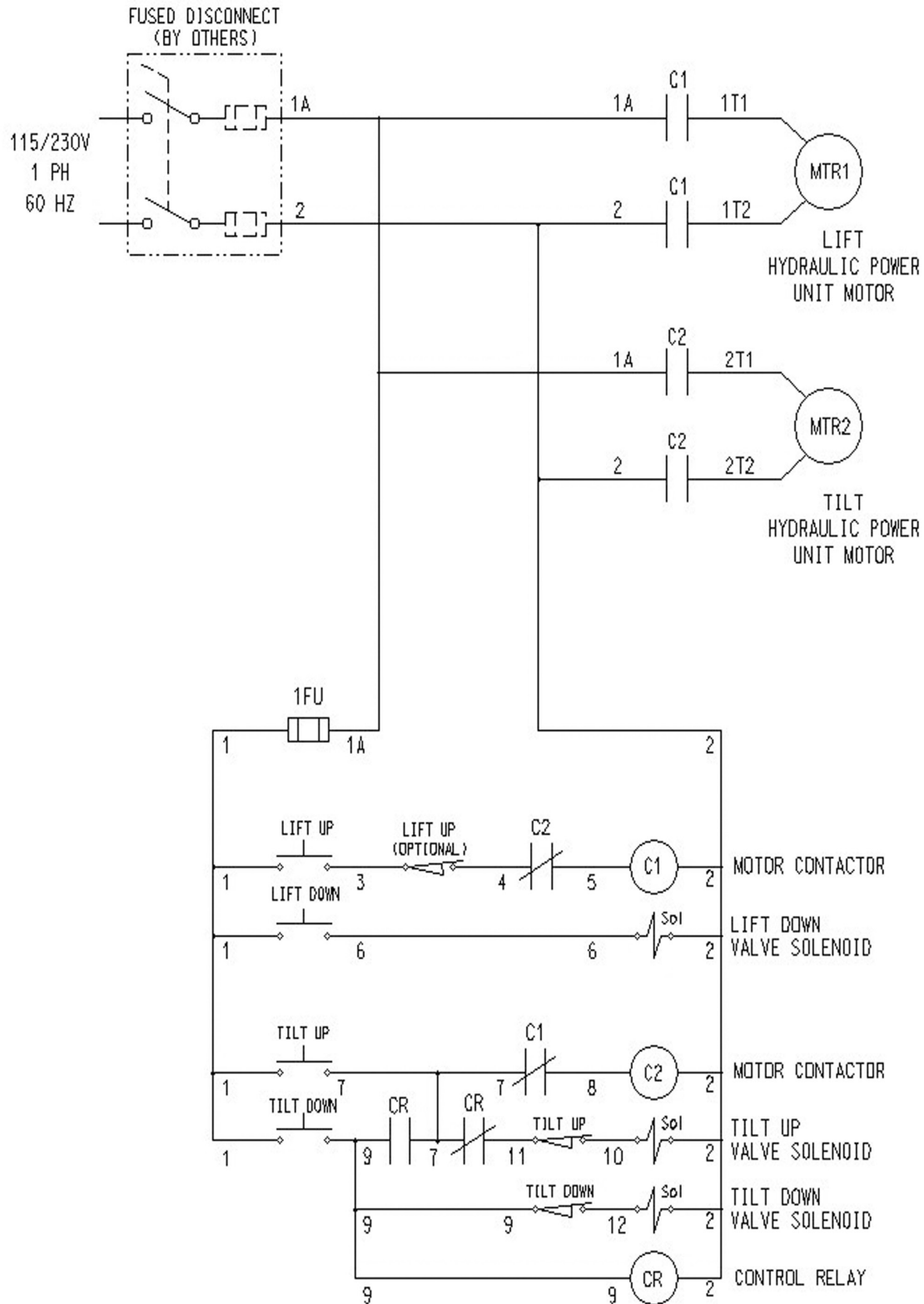

NOTE:

- 1.) THIS DIAGRAM MAY ALSO BE USED WHEN FOOTSWITCHES ARE USED IN PLACE OF PUSHBUTTONS.
- 2.) IF UP LIMIT SWITCH (OPTIONAL) IS ABSENT RUN WIRE #3 TO THE AUXILIARY CONTACT ON TILT MOTOR CONTACTOR.

Figure 15. Electrical Connections for Single Phase AC

OPERATING AND MAINTENANCE MANUAL

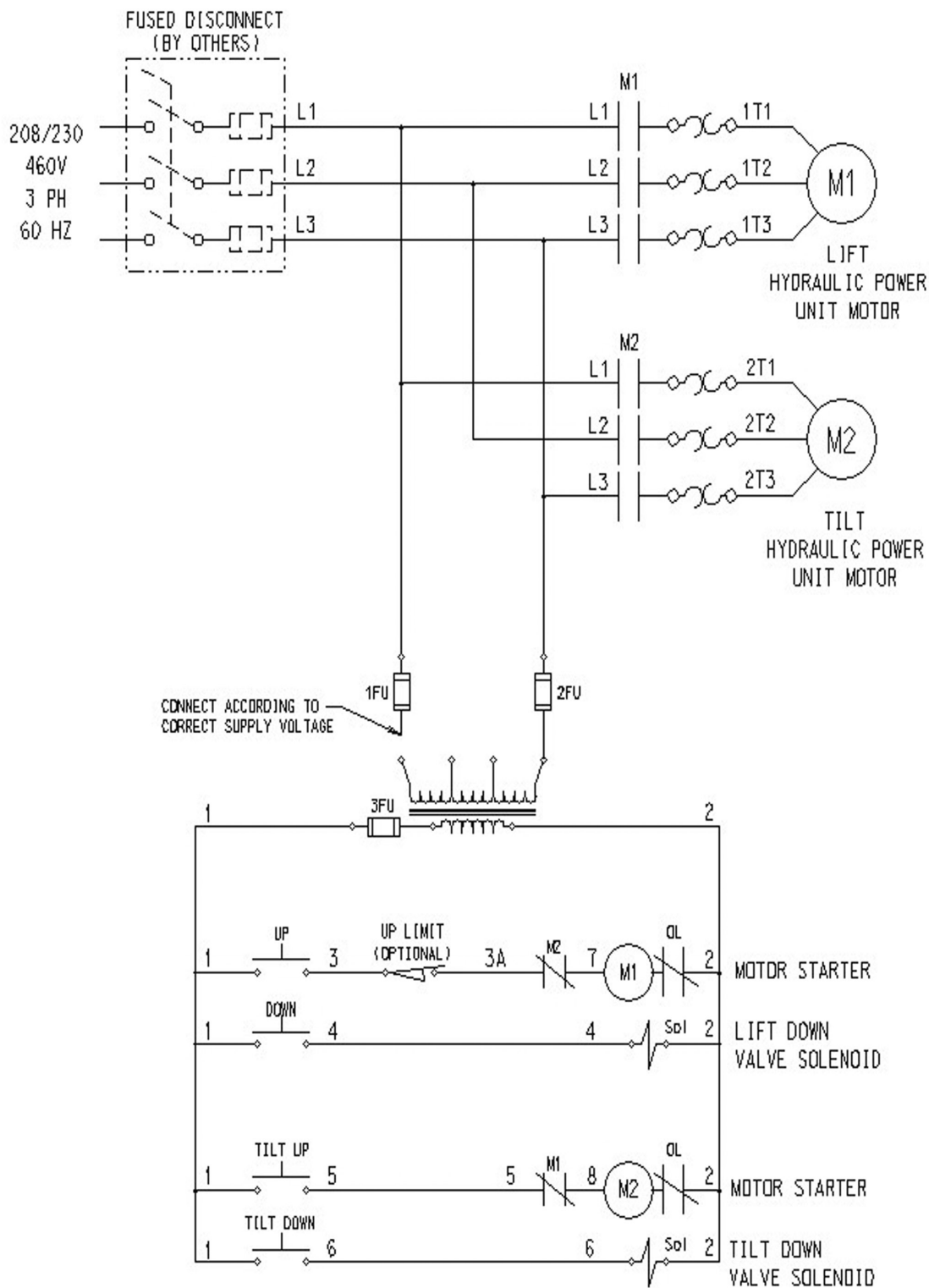

NOTE:
UPPER TRAVEL LIMITSWITCH IS OPTIONAL.
IF UP LIMIT IS ABSENT, CONNECT WIRE 3
DIRECTLY TO NC CONTACT ON MOTORSTARTER.

Figure 16. Electrical connections for Three Phase AC

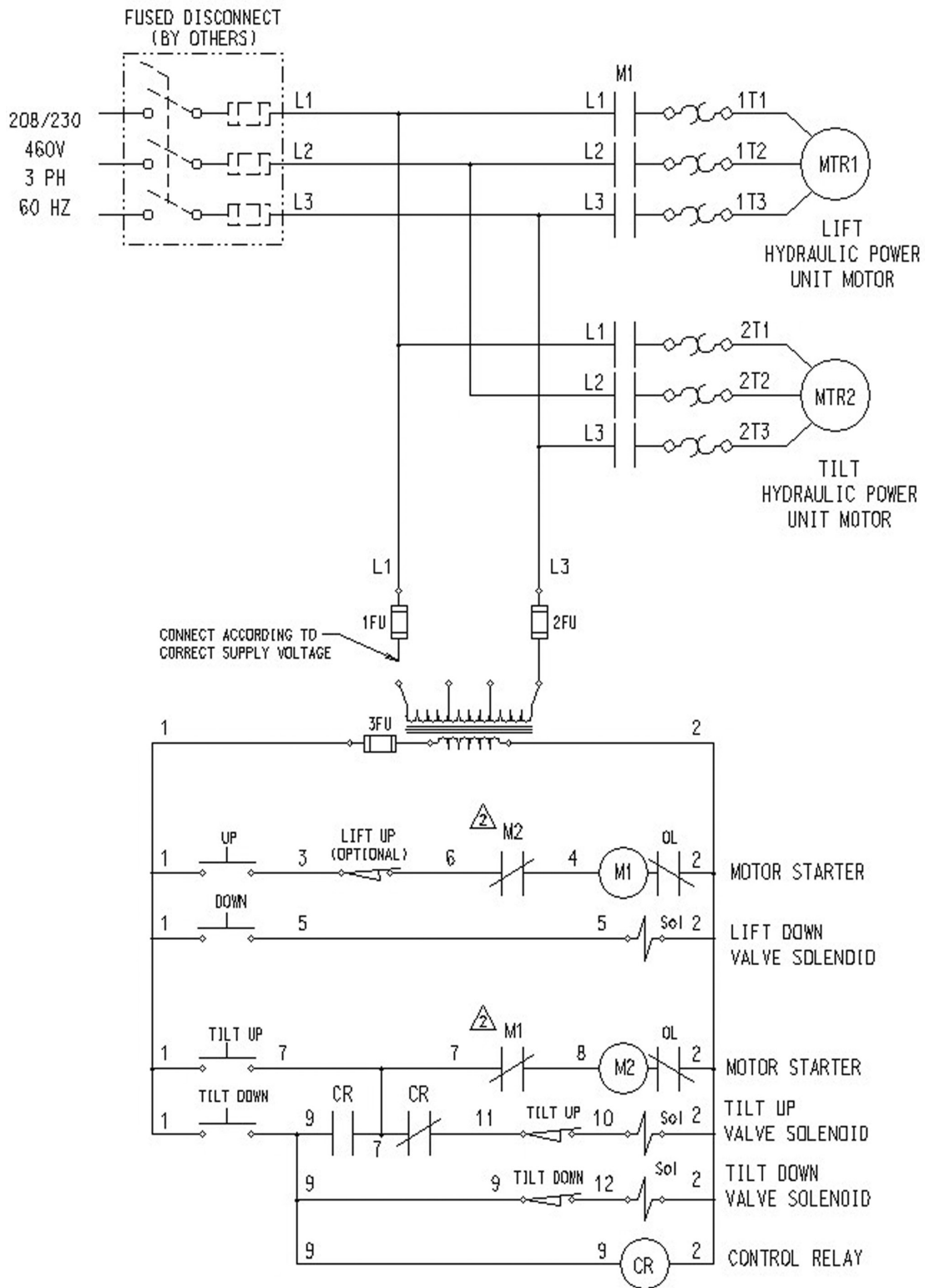

NOTE:

- 1.) THIS DIAGRAM MAY ALSO BE USED WHEN FOOT SWITCHES ARE USED IN PLACE OF PUSHBUTTONS.
- 2.) IF LIFT UP LIMIT SWITCH IS ABSENT RUN WIRE #3 DIRECTLY TO THE N.C. CONTACT ON M2 MOTOR STARTER.

Figure 17. Hydraulic Schematics for Single Phase AC & Three Phase AC

2 YEAR WARRANTY

Southworth Products Corp warrants this product to be free from defects in material or workmanship for a period of 2 years of single shift usage from date of shipment, providing claim is made in writing within that time period. This warranty shall not cover modified designs for special applications, failure or defective operation caused by misuse, misapplication, negligence or accident, exceeding recommended capacities, failure to perform required maintenance or altering or repairing, unless alteration is authorized by Southworth Products Corp. Except as set forth herein, there are no other warranties, express or implied, including the warranties of merchantability and fitness for a particular purpose, all of which are hereby excluded.

Southworth Products Corp makes no warranty or representation with respect to the compliance of any product with state or local safety or product standard codes, and any failure to comply with such codes shall not be considered a defect of material or workmanship under this warranty. Southworth Products Corp shall not be liable for any direct or consequential damages arising out of such noncompliance.

Southworth Products Corp's obligation under this warranty is limited to the replacement or repair of defective components at its factory or another location at Southworth Products Corp's discretion. The Southworth Warranty is for product sold with in North America. For products shipped outside of North America the warranty will be for replacement of defective parts only. Labor is not included. This is buyer's sole remedy. Except as stated herein, Southworth Products Corp will not be liable for any loss, injury or damage to persons or property, nor for direct, indirect, or consequential damage of any kind, resulting from failure or defective operation of said product.

This warranty may be altered only in writing by Southworth Products Corp, Portland, Maine.

SOUTHWORTH

SOUTHWORTH PRODUCTS CORP
P.O. Box 1380, Portland, ME 04104-1380
Telephone: (800) 743-1000 • (207) 878-0700
Fax: (207) 797-4734
www.SouthworthProducts.com

SOUTHWORTH

making work faster, safer, and easier

Southworth is the world class supplier of products designed to improve productivity and enhance safety. Our staff has over 400 years of engineering experience. If one of our standard products does not meet your needs, our engineers can custom design equipment specifically suited to your material handling application.



Spring PalletPal Load Leveler



Lift with Flush Mount Turntable



Portable Container Tilters



Dock Lifts



Roll on Level Loaders



Portable Lifts



Stack-n-Go Powered Stacker



**Floor Height Lifts
Roll-E**

**Floor to
Mezzanine Lifts**



Pallet Rotators



For more information, contact Southworth Products
Telephone (800) 743-1000 Fax (207) 797-4734
Email: salesinfo@SouthworthProducts.com