

SOUTHWORTH

ROLLCTT 2.5-28 Owner's Manual



Model: _____
Serial Number: _____
Date placed in
service: _____

SOUTHWORTH PRODUCTS CORP.
P.O. Box 1380, Portland, ME 04104-1380
Telephone: 800-743-1000 • 207-878-0700
Fax: 207-797-4734
www.SouthworthProducts.com

Contents

1	Introduction.....	4
1.1	Responsibilities of Owner and Users.....	4
1.2	Responsibilities of Operators.....	5
2	Safety.....	7
2.1	Safety Alert Symbols	7
2.2	Signal Words	7
2.3	Safety Devices.....	7
3	Labeling.....	8
3.1	Label Location Diagram	8
4	Installation.....	9
5	Operation.....	11
5.1	Loading	12
5.2	Raising & Lowering the Platform.....	12
5.3	Status Indicator	12
6	Maintenance & Repair	13
6.1	Periodic Maintenance	13
6.2.2	Every Month	13
6.3.3	Every Six Months`	13
6.4	Relieving Hydraulic System Pressure.....	14
6.5	Ordering Replacement Parts.....	15
7	Troubleshooting	15
8	Procedures.....	17
8.1	Cleaning the Down Valve.....	17
9	Electrical	17
9.1	Wiring Schematics	17
9.2.2	Prior to February 2019.....	17
9.3.3	February 2019 to Present.....	18
10	Hydraulics	19
10.1	Hydraulic Power Unit.....	19
10.2	Hydraulic Schematic.....	19
11	Components.....	20
12	Warranty & Contact Information	21



**This label (part # 10095524)
is required by California law.
For more information visit
www.P65Warnings.ca.gov.**

1. Introduction

1.1 Responsibilities of Owner and Users

Basic Principles - Owners/users shall apply sound principles of safety, training, inspection, maintenance, and expected operating environment. It shall be the responsibility of the owner/user to advise the manufacturer where deflection may be critical to the application.

Manuals - Owners/users shall keep and maintain a copy of the operating and maintenance manual(s) and ensure its availability to operating and maintenance personnel.

Inspection and Maintenance - It shall be the responsibility of the users to inspect and maintain the machine as required to ensure proper operation. The frequency of inspection and maintenance shall be based upon the manufacturer's recommendations and be compatible with operating conditions and the severity of the operating environment. Machinery that is not in proper operating condition shall be immediately removed from service until repaired. Maintenance and repairs shall be made by a qualified person and the repairs shall be in conformance with the manufacturer's recommendations.

Maintenance Safety Precautions - Before adjustments and repairs are started on the machine, the following precautions shall be taken as applicable:

1. Remove the load from the load enclosure.
2. Lower platform to the full down position.
3. Relieve system pressure from all circuits before loosening or removing any components.
4. All controls in the "off" position and all operating features secured from inadvertent motion by brakes, blocks, or other means.
5. Disconnect power and follow established owner/user lockout/tag out policies.
6. Follow precautions and directions as specified by the manufacturer.

Replacement Parts - When parts or components are replaced, they shall be replaced with parts or components approved by the original manufacturer.

Maintenance Training - The user shall ensure only qualified personnel inspect and maintain the machine in accordance with the manufacturers recommendations.

Operator Training - An owner/user, who directs or authorizes an individual to operate the machine shall ensure that the individual has been:

1. Trained in accordance with the manufacturer's operating manual.
2. Made aware of the responsibilities of operators as outlined in section 1.4 of this manual.
3. Retrained, if necessary, based on the owners/user's observation and evaluation of the operator.

Modifications and additions shall not be performed without the manufacturer's prior written approval. Where such authorization is granted, capacity, operation, and maintenance instruction plates, tags, or decals shall be changed accordingly.

1.2 Responsibilities of Operators

Basic Principles - Operators shall apply sound principles of safety and good judgment in the application and operation of the machine with consideration given to its intended use and expected operating environment. Since the operator is in direct control of the machine, conformance with good safety practices is the responsibility of the operator. The operator shall make decisions on the use and operation with due consideration for the fact that his or her own safety as well as the safety of other personnel on or near the machine is dependent on those decisions.

General Training - Only personnel who have received general instructions regarding the inspection, application and operation of machine, including recognition and avoidance of hazards associated with their operation, shall operate the machine. Such topics covered shall include, but not necessarily be limited to, the following issues and requirements:

1. A pre-start inspection
2. Responsibilities associated with problems or malfunctions affecting the operation of the machine.
3. Factors affecting stability
4. The purpose of placards and decals
5. Workplace inspection
6. Safety rules and regulations
7. Authorization to operate
8. Operator warnings and instructions
9. Actual operation of the machine. Under the direction of a qualified person, the trainee shall operate the machine for a sufficient period of time to demonstrate proficiency in actual operation of the machine.

Pre-start Inspection - Before use each day or at the beginning of each shift, the machine shall be given a visual inspection and functional test including but not limited to the following:

1. Operating and emergency controls
2. Safety devices
3. Hydraulic system leaks
4. Electrical cables and wiring harness
5. Loose or missing parts
6. Nameplates, precautionary and instructional markings and/or labeling
7. Guarding system
8. Items specified by the manufacturer

Problem or Malfunctions - Any problems or malfunctions that affect the safety of operations shall be repaired prior to the use of the machine.

Before Operations - The operator shall:

1. Read and understand the manufacturer's operating instruction(s) and user's safety rules or have them explained
2. Understand all labels, warnings, and instructions displayed on the machine or have them explained.

Workplace Inspections - Before the machine is used and during use, the operator shall check the area in which the machine is to be used for possible hazards such as, but not limited to:

1. Bumps, floor obstructions and uneven surfaces
2. Overhead obstructions and electrical hazards
3. Presence of unauthorized persons
4. Other possible unsafe conditions as noted in the operating manual.

Operator Warnings and Instructions - The operator shall ensure the operation of the machine is in compliance with the following:

Guarding system - Guarding shall be installed and positioned, and access gates or openings shall be secured per the manufacturer's instructions.

Distribution of load - The load and its distribution on the platform shall be in accordance with the manufacturer's rated capacity for that specific configuration.

Maintaining overhead clearance - The operator shall ensure that adequate clearance is maintained from overhead obstructions and energized electrical conductors and parts.

Point of Operation - The operator shall not place any part of their body under the platform.

Precaution for moving equipment - When other moving equipment or vehicles are present, special precautions shall be taken to comply with the safety standards established for the workplace.

Reporting problems or malfunctions - The operator shall immediately report to a supervisor any problem(s) or malfunction(s) that become evident during operation. The operator shall ensure all problems and malfunctions that affect the safety of operations are repaired prior to continued use.

Capacity limitation - Rated capacity shall not be exceeded when loads are transferred to the load enclosure.

Work area - The operator shall ensure the area surrounding the machine is clear of personnel and equipment before lowering the load enclosure.

Securing the machine - The operator shall comply with the means and procedures provided to protect against use by an unauthorized person(s).

Altering safety devices - Safety devices shall not be altered or disabled.

Modifications or alterations of the machine or the fabrication and attaching of frameworks or the mounting of attachments to the machine or the guarding system shall only be accomplished with prior written permission of the manufacturer.

Assistance to the operator - If an operator encounters any suspected malfunction or any hazard or potentially unsafe condition relating to capacity, intended use or safe operation the operator shall cease operation of the machine and request further instruction from the owner/user.

Problems or malfunctions - Any problem(s) or malfunction(s) that affect the safety of operations shall be repaired prior to the use of the machine.

2. Safety

All personnel installing, operating, and maintaining this machine shall read and understand this manual. For questions or concerns contact the manufacturer.

This machine shall be installed, operated, and maintained by trained and/or qualified personnel only.



2.1 Safety Alert Symbols

A symbol that indicates a hazard. It is composed of an equilateral triangle surrounding an exclamation mark. The safety alert symbol is only used on hazard alerting signs. It is not used on safety notice and safety instructions signs.

A – For use with **DANGER** signal word; (safety white triangle, safety red exclamation mark, safety red background)

B – For use with **WARNING** signal word; (safety black triangle, safety orange exclamation mark)

C – For use with **CAUTION** signal word; (safety black triangle, safety yellow exclamation mark)

D – For use with **DANGER, WARNING, or CAUTION** signal words; (**D** is a safety yellow triangle with a safety black border and safety black exclamation mark;

2.2 Signal Words



DANGER Indicates a hazardous situation that, if not avoided, will result in death or serious injury.



WARNING Indicates a hazardous situation that, if not avoided, could result in death or serious injury.



CAUTION Indicates a hazardous situation that, if not avoided, could result in minor or moderate injury.



NOTICE Indicates information considered important, but not hazard-related (e.g., messages relating to property damage).

2.3 Safety Devices

This machine is equipped with devices and features to protect the operator and nearby personnel from severe injury or death. These features and devices shall be installed and functioning correctly during operation.

Photo-eye toe protection – This machine has three sets of photo eyes providing protection for the operator's toes while the platform is lowering. These are located along the front load-edge, and the along the base rails (both sides). If the beams of any of the photo eyes are obstructed, the lift will not lower. The obstruction must be cleared before operation can proceed.

One additional photo eye is located in the mast of the machine that is activated when the platform is approximately eight inches from the floor and the turntable position switch is opened. If the turntable length and width is not aligned with the outriggers and the load edge aligned with the edge of the ramp, this photo eye prevents the platform from lowering below seven inches.

The photo eye emitters have two LEDs on them. The yellow LED indicates output power. The green LED indicates that the photo eyes are properly aligned. These lights will be on if the photo eyes are functioning properly.

3. Labeling

This machine has labeling to indicate potential hazards this machine may pose when operating and/or maintaining the machine. All labels must be legible. If any label is missing, damaged, or otherwise illegible contact the manufacturer for replacement labels.

NOTICE

Items 12-14 apply machines manufactured after February 2019 only.

3.1 Label Location Diagram

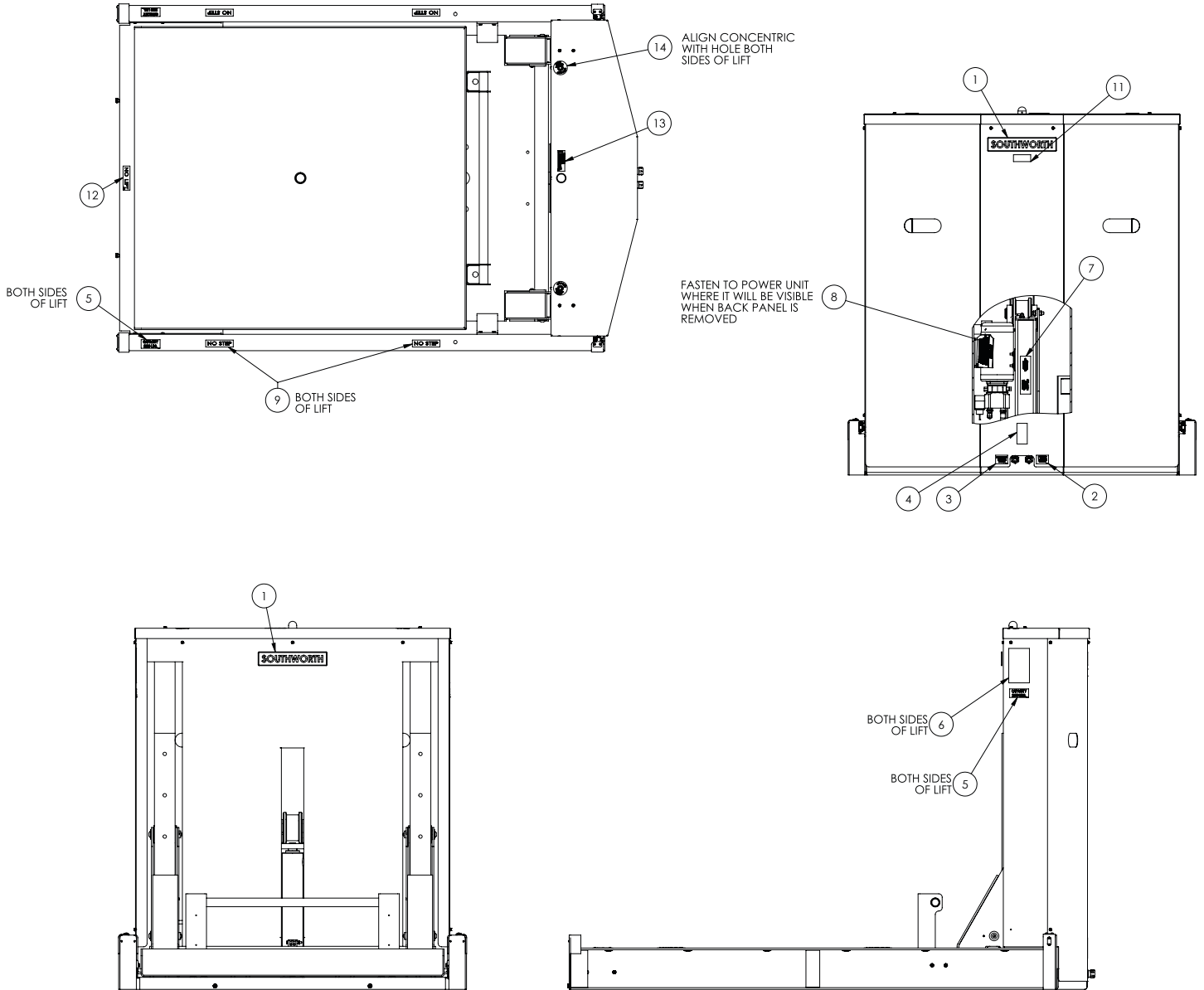

14	2	EA	LD DCL 2.00 LIFT POINT	10098843
13	1	EA	LD DCL 1.00X3.00 GREEN YELLOW RED	10098834
12	1	EA	LD DCL 1.00X3.50 NO LIFT	10098832
11	1	EA	LD WARNING CANCER AND REPRODUCTIVE	10095524
10	2	EA	LD DCL 2.00X3.00 SOUTHWORTH SERIAL ID BL	10079929
9	4	EA	BK-LD DCL 1.00X4.00 NO STEP	2990768
8	1	EA	LD DCL 2.50X5.00 PROPER INSTALLATION IS	2998365
7	1	EA	BK-LD DCL 1.50X5.50 TANK TO BE FULL ONLY	2986997
6	2	EA	LD DCL 3.00X6.00 DANGER MAST LIFT & STAC	10098025
5	4	EA	LD DCL 1.25X2.75 CAPACITY 2500 LBS	2998435
4	1	EA	BK-LD DCL 3.00X1.50 ARC FLASH AND SHOCK	10047672
3	1	EA	BK-LD DCL 1.25X1.75 CONTROL, 115V 1 PHAS	2986999
2	1	EA	BK-LD DCL 1.25X1.75 POWER	2987000
1	2	EA	BK-LD TAG 2.00X10.00 SOUTHWORTH	5900158
ITEM NO.	QTY.	U/M	DESCRIPTION	PART NO.

4. Installation

Before Installation read and understand this manual. **Only trained and/ or qualified personnel shall install this machine.** Remove all packaging and inspect the machine for damage and/ or missing components. Contact the manufacturer if damage is found or components are missing.

The owner/ installer is responsible for ensuring all codes and ordinances are met and any necessary permits are obtained prior to installation.

Anchoring this machine is optional. Four anchor holes are provided if anchoring the machine is preferred.

⚠ DANGER

Electric motors can create sparking, do not install in an area where flammable materials are present.

This machine must be installed in an area protected from rain and moisture.

This machine must be installed and operated on a solid, level surface capable of supporting the machine at it's rated capacity.

Do not sit, stand, or ride on the platform.

NOTICE

This machine is powered by a 115/1/60 one horse power motor and requires a dedicated 20 amp circuit. Extension cords must not be used.

To remove the machine from shipping pallet and into the desired position two 1/2-13 UNC eye bolts are required (not provided). Insert these into the two lift point holes on top of the mast. Always use two lifting eyes. Machine weight is approximately 1,600 Lb.

Do not lift the machine from the platform, outriggers, or cross member between the outriggers or damage will occur.

Platform stops must be removed before operation.

To move the machine into position:

1. Thread a 1/2-13 UNC eye bolt into each of the lift point holes. Holes are located on top of the mast.
2. Attach a load spreader to the eye bolts. Chains/cables/straps should lift vertically on the eye bolts.
3. Using a crane or other appropriate lifting device carefully raise the machine off the pallet.
4. Slowly and carefully move the machine to the desired position.

NOTICE

The machine may not hang level. Do not drag outriggers when moving the machine.

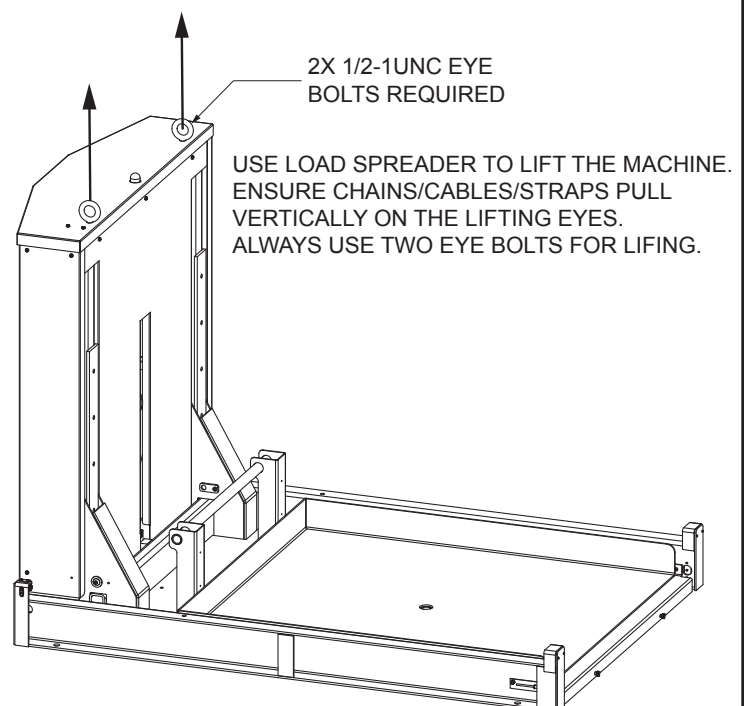

If machine is not equipped with lifting points:

- Using a fork lift, slowly and carefully insert the forks under the edge of the outrigger of the side without the photo eye wiring as shown in the image below. Forks must be inserted so that the machine's center of mass is supported during lifting.

WARNING

The machine's center of mass must be supported during lifting or the machine may become unstable, fall, and cause severe injury or damage to the machine.

NOTICE

Take care not to damage the platform when inserting forks.

- As the machine is lifted insert blocking under the outrigger to allow the forks to be re-adjusted as needed. The forks should be inserted as far under the outriggers as possible, without damaging the machine.
- Secure the machine to the forks, if necessary, to prevent the machine from falling during transport.

NOTICE

Do not lift the machine by the platform. Lifting the machine by the platform will cause damage to the machine.

Machine weights approximately 1600 lb. Use only appropriately rated fork lift.

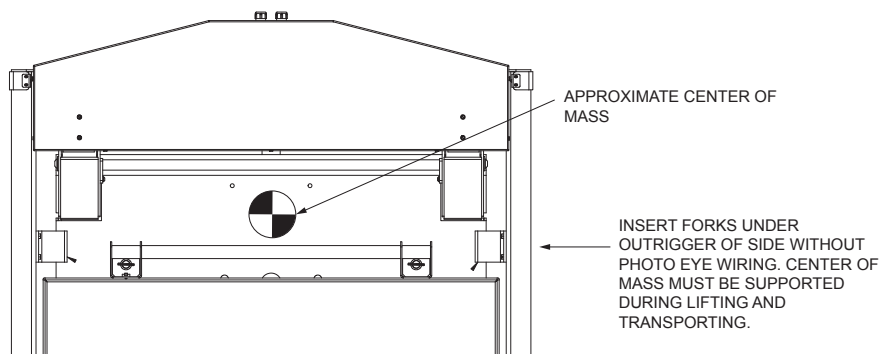

If anchoring the machine:

- Mark the location of the anchor holes.
 - Move the machine to allow the anchor holes to be drilled.
 - Drill holes for the anchors.
 - Return the machine to the desired location.
 - Insert anchors and tighten per anchor manufacturer's specifications.
- Remove the platform stops. The stops are located along the base rails toward the mast end of the machine.

NOTICE

Platform stops must be removed prior to operation or machine may be damaged.

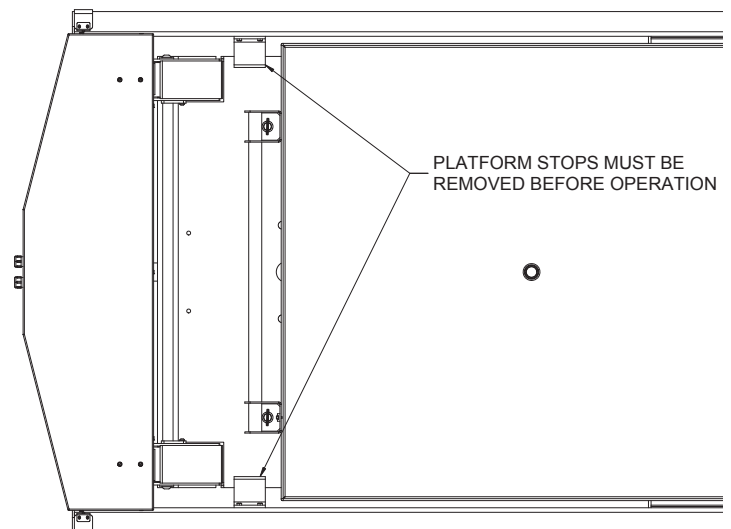

- Plug the power cord into the dedicated 20 amp 115/1/60 circuit.
- Test the function of the machine by raising and lowering the platform with no load on the platform.
- Install the ramp by sliding the slots on the ramp over the bolts on the base cross member.

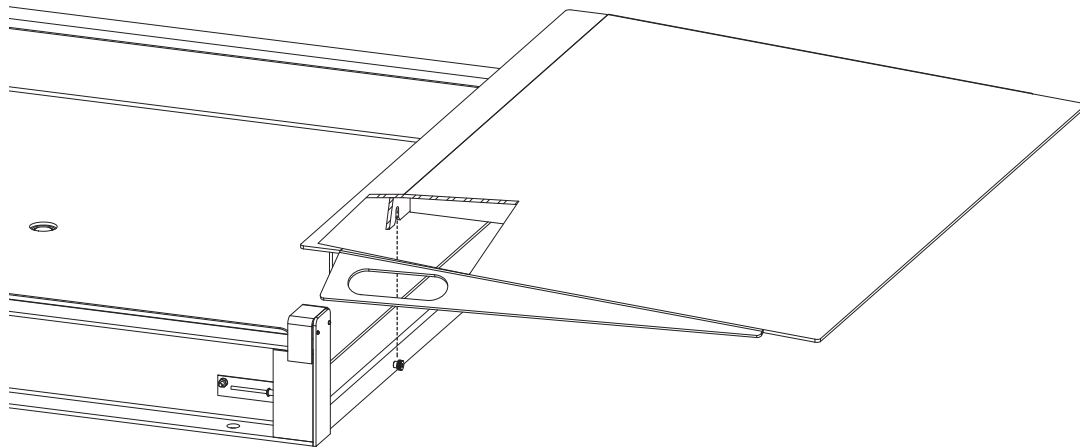

Ramp Installation

5. Operation



Crush, pinch, and shear points exist; keep hands, feet, and loose clothing away from machine during operation.

Do not enter beneath the platform.

Verify the area around the machine is clear of debris and/ or personnel before operating.

This machine is shipped with two platform stops in place. These must be removed before operation.

Only trained and/ or qualified personnel shall operate this machine. Personnel operating this machine must read and understand this manual.

Do not sit, stand, or ride on platform.

Before each use, inspect the machine for excessive wear or damage. Verify all precautionary labeling is legible. Verify all photo eyes and turntable position switch are functioning correctly. The platform must not lower if any photo eye is obstructed. The platform must not lower below seven inches if platform is not properly aligned with the outriggers. Verify Status indicator mounted on top of mast functions correctly. See Status Indicator in Operation section.

NOTICE

Machines manufactured before February 2019 are not equipped with status indicator.

5.1 Loading

WARNING

Loads must not exceed the rated capacity. Overloading can cause damage or failure, which may lead to severe injury.

Any load that may shift during raising or lowering must be secured.

When loading the machine, the load must be centered on the platform. If the load is uneven the heaviest part of the load is to be placed toward the mast of the machine to avoid excessive deflection. Due to the cantilever design, some deflection will occur.

5.2 Raising & Lowering the Platform

NOTICE

This machine has three photo eye circuits located on the loading edge, and the two side rails. If these photo eyes detect an obstruction the platform will not lower.

This machine has one additional photo eye located in the mast of the machine that becomes active when the platform is approximately seven inches from the floor and the turntable position switch is opened. If the turn table length and width is not aligned with the outriggers and the load edge aligned with the edge of the ramp, this photo eye prevents the platform from lowering below eight inches.

Before raising or lowering the platform verify that all debris and/ or personnel are clear of the machine.

To raise the platform, press and hold the UP button on the controls until the platform is at the desired height.

To lower the platform, press and hold the DOWN button on the controls until the platform is at the desired height.

5.3 Status Indicator

The multi colored light mounted on top of the mast indicates status of the machine.

- **Green** – Indicates no fault, machine should function without issue.
- **Yellow** – Indicates misalignment of the turntable. Align turntable sides with outriggers before continuing.
- **Red** – Indicates that toe sensors have been triggered. Ensure all obstructions are removed before continuing.

6. Maintenance & Repair



To avoid death or serious injury:

- High Voltage can cause severe injury or death. Disconnect and lockout electrical power before performing maintenance or repair.
- Only trained and/ or qualified personnel shall perform and maintenance or repair.
- High pressure fluids can penetrate skin and cause severe injury or death. Always relieve hydraulic system pressure before performing maintenance or repair of the hydraulic system. See Relieving Hydraulic System Pressure section.
- Never enter beneath the raised platform.
- If damage or excessive wear is found, remove the machine from service until the machine is repaired.
- All maintenance too be performed with the platform in the fully lowered position.

6.1 Periodic Maintenance

- Before each use, inspect the machine for excessive wear or damage. Verify all precautionary labeling is legible.
- Verify all photo eyes and turntable position switch are functioning correctly. The platform must not lower if any photo eye is obstructed. The platform must not lower below eight inches if platform is not properly aligned with the outriggers. **See Operation Section.**
- Verify Status indicator mounted on top of mast functions correctly. **See Status Indicator in Operation section.**

6.1.1. Every Month

- Inspect the rollers and roller tracks, cylinder sheave, chain and turntable pivot. **See Hydraulic Power Unit/Components section.**
- Inspect all hydraulic fittings and connections for leaks or damage.
- Inspect the hydraulic cylinder. Excessive fluid in the vent line may indicate leaking seals within the cylinder.
- Inspect the hydraulic fluid. Fluid level should be approximately 3/4 of an inch from the top of the reservoir when the platform is lowered. Fluid should be clear and free of debris. Fill tank only when platform is lowered.
- Inspect photo eyes, and turntable position switch for proper adjustment and operation. Check, operator push button or foot switch for proper operation. Inspect all wiring for secure connections and sound wiring, including grounds and electrical components.

6.1.2. Every Six Months`

- Perform Monthly inspections.
- Change the hydraulic fluid and clean the suction strainer.
 - Drain all hydraulic fluid from the tank and cylinder.
 - Remove the suction strainer from the tank. Clean the strainer using compressed air and reinstall.
 - Fill tank with new fluid. Use only hydraulic fluids approved by the manufacturer. Raise and lower the platform six to seven times to remove air from the system. Check hydraulic fluid level again with platform in lowered position. **See Hydraulics section.**

6.2 Relieving Hydraulic System Pressure

If the machine is operating normally, hydraulic system pressure can be relieved by lowering the platform to the fully lowered position and continuing to hold the down button for several seconds.

If the platform is raised and will not lower:



Crush Hazard – Do not enter under the platform.

Remove load before performing any maintenance or repair.

Disconnect and lockout electrical power before performing maintenance or repair.

Failure to securely block the platform from lowering will allow the platform to fall uncontrolled when system pressure is relieved, potentially causing severe injury or death. Blocking/cribbing chosen must be able to safely support a 2000 lb. static load.

High pressure fluid can cause severe injury or death. Always use proper personal protective equipment when performing any maintenance or repair.

NOTICE

Take care not to damage the platform when using fork lift for support.

- Check to make sure the down valve solenoid is receiving the proper voltage and is functioning correctly.
- If the solenoid is functioning correctly and the platform will not lower, use a fork truck to prevent the platform from falling when system pressure is released. Carefully insert the forks beneath the platform and raise the forks until the fork truck is supporting the platform.

NOTICE

Do not continue to raise the forks after that contact the bottom of the platform or the machine may be damaged. Other secure blocking may be used to prevent the platform from falling when system pressure is released.

- Carefully and slowly loosen the connection from the cylinder to the pump, on the pump side, as shown in diagram. The fluid in the hose will be pressurized and will leak.
- Use a clean container to catch fluid from the line as the fitting is loosened. Use an oil absorbent to clean any spills. Caught fluid can be reused.

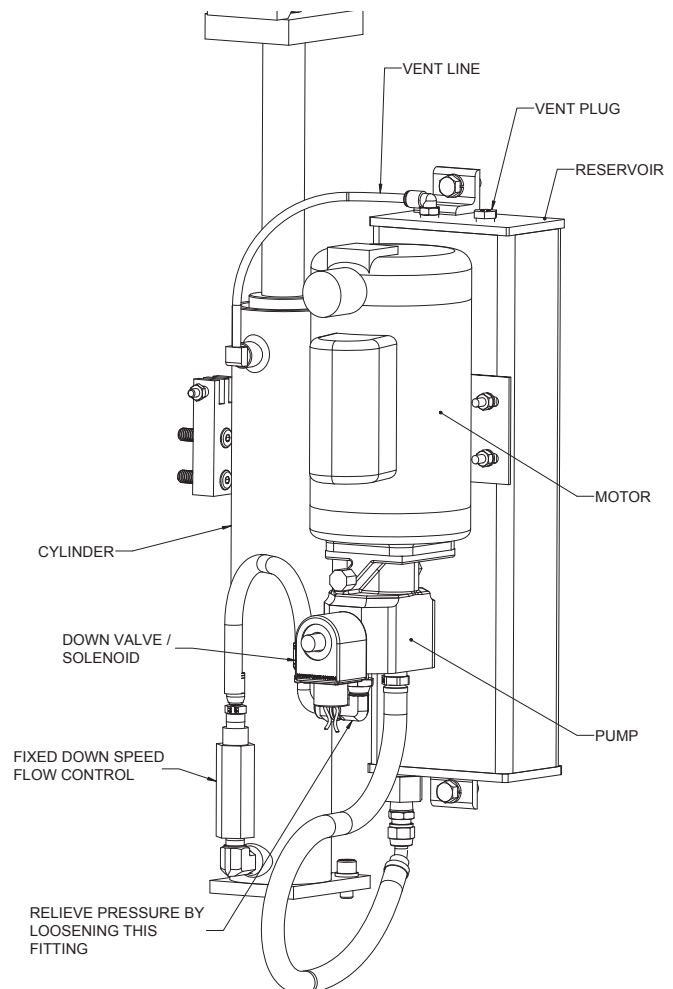

6.3 Ordering Replacement Parts

Southworth has carefully chosen the components in your lift to be the best available for the purpose. Replacement parts should be identical to the original equipment. Southworth will not be responsible for equipment failures resulting from the use of incorrect replacement parts or from unauthorized modifications of the machine.

Southworth will gladly supply you with replacement parts for your Southworth lift. With your order, please include the model number and the serial number of the lift. You can find these numbers on the name plate. When you are ordering parts for a cylinder, also include the cylinder number. This is stamped on the base of the cylinder housing.

To order replacement parts, please call the Parts Department. See Warranty & Contact Information section.

- Parts are shipped subject to the following terms:
- FOB factory
- Returns only with the approval of our parts department.
- Payment net 30 days (except parts covered by warranty).
- Freight collect (except parts covered by warranty).
- The warranty for repair parts is 30 days from date of shipment.

Parts replaced under warranty are on a “charge-credit” basis. We will invoice you when we ship the replacement part, then credit you when you return the worn or damaged part, and we verify that it is covered by our warranty. Labor is not covered under warranty for Parts orders.

7. Troubleshooting

Symptom	Possible Cause	What to Look For
Platform will not raise.	Power unit not receiving power.	Check that machine is plugged into a 115/1/60 outlet on a dedicated 20 amp circuit and outlet is powered.
	Up limit switch (if applicable) may be activated or defective.	Verify up limit switch is not activated or malfunctioning.
	Excessive loading	Verify that load on the platform does no exceed the rated capacity of the machine.
	Hydraulic fluid may be low.	With the platform in the lowered position, the fluid should be approximately 3/4 of an inch from the top of the reservoir.
	The reservoir vent may be blocked.	Verify that the vent cap on the top of the reservoir is not blocked.
	The suction filter may be blocked.	Drain the fluid from the reservoir and clean the suction filter.

Symptom	Possible Cause	What to Look For
Platform will not raise.	A vacuum leak in the hydraulic system may be causing cavitation.	Inspect all hydraulic hoses and fittings for loose connections or leaks.
	The motor may not be receiving the correct voltage.	Check the supply voltage. The supply voltage must be within $\pm 5\%$ of the rated voltage.
	The down valve solenoid may be energized.	Verify the down valve is not energized.
	The down valve may be stuck open.	Remove and inspect the down valve and solenoid. Clean, reassemble, and reinstall.
Platform will not stay raised	The down valve may be energized.	Verify the down valve is not energized.
	The down valve may be stuck open.	Remove and inspect the down valve and solenoid. Clean, reassemble, and reinstall. See Cleaning the Down Valve Section.
	Seals in the cylinder may be leaking	Oil on the on the cylinder or excessive fluid in the vent line may indicate leaking seals.
Platform will not lower.	One or more of the photo eye beams may be obstructed or photo eyes may be misaligned.	Verify there are no obstructions of the photo eye beams. The yellow and green LED on the emitter should both be on. The status indicator illuminated red.
	Platform may not be in the correct position for lowering or turntable position photo eye is obstructed (required for lowering below eight inches).	Verify the platform is turned so the sides are parallel with the base rails and the load edge is toward the ramp. Verify there is nothing obstructing the photo eye. The status indicated illuminated yellow.
	Turntable position switch may be out of adjustment or defective.	Switch only to be open when platform is approximately seven inches from floor and lower.
	The down valve may not be energized.	Verify the down valve is being energized.
	The down valve may be blocked from opening.	Remove and inspect the down valve and solenoid. Clean, reassemble, and reinstall. See Cleaning the Down Valve Section.

9.1.2. February 2019 to Present

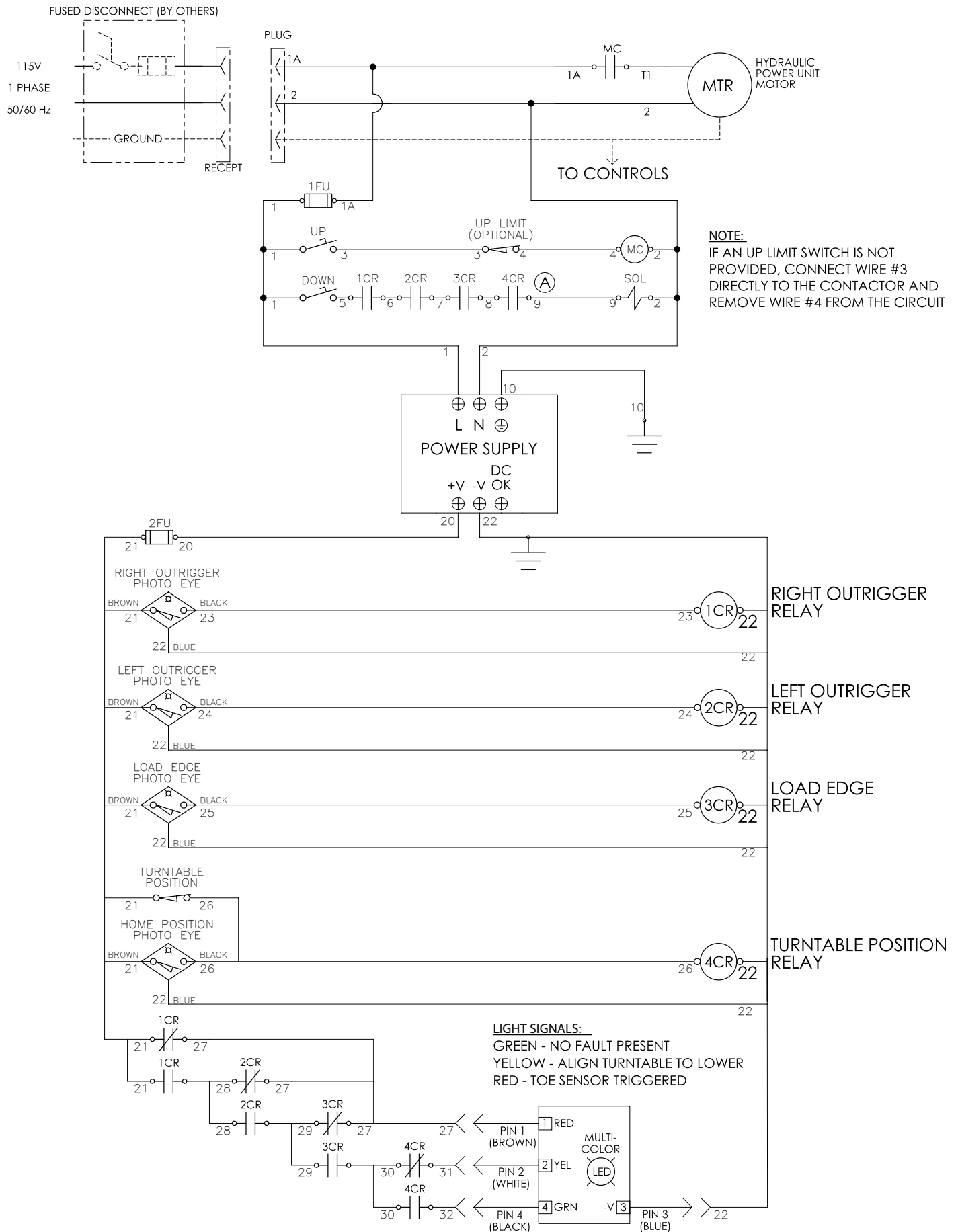

10. Hydraulics

Motor : 1.0 HP

Power: 115/1/60

Pump: 0.8 GPM

Controls: 115/1/60

Standard Hydraulic Fluid: Citgo AW 32 or equivalent

10.1 Hydraulic Power Unit

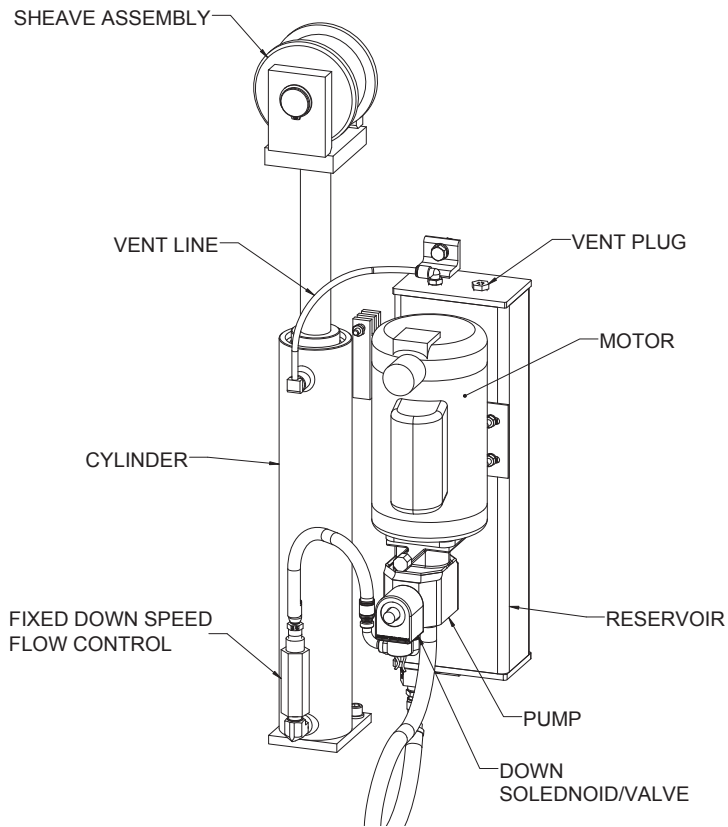

10.2 Hydraulic Schematic

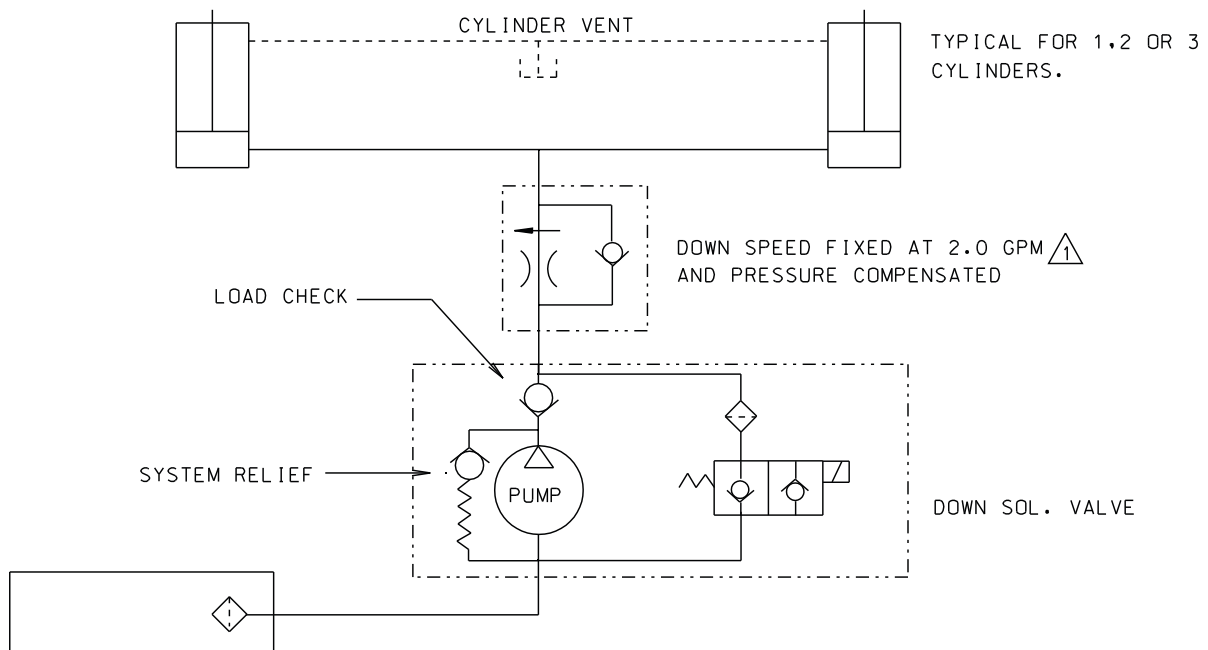

11. Components

NOTICE

Lift points and status indicator apply to machines manufactured after January 2019 only.

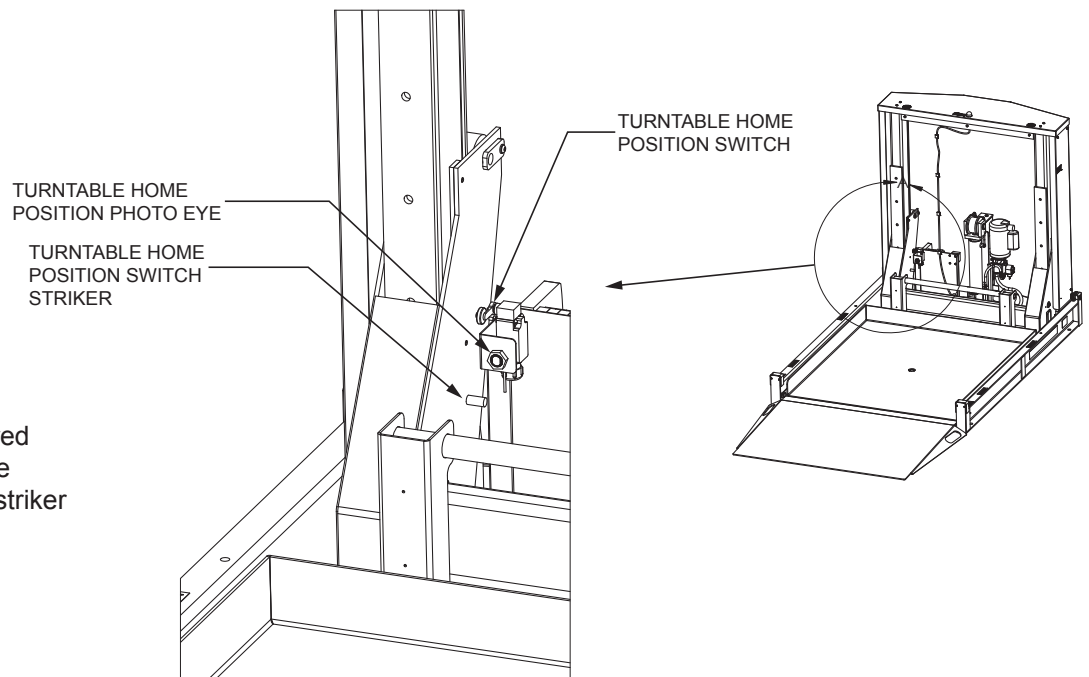
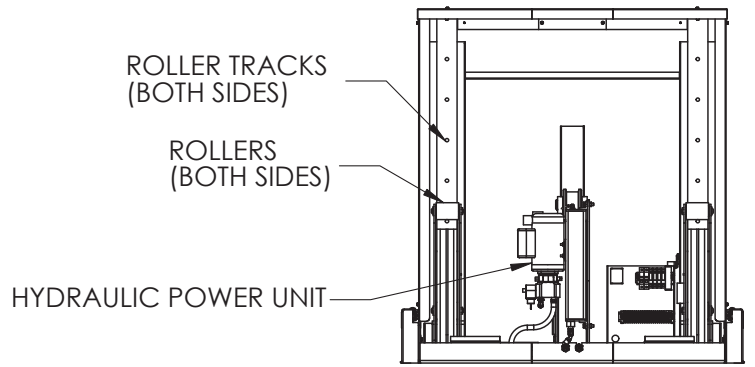
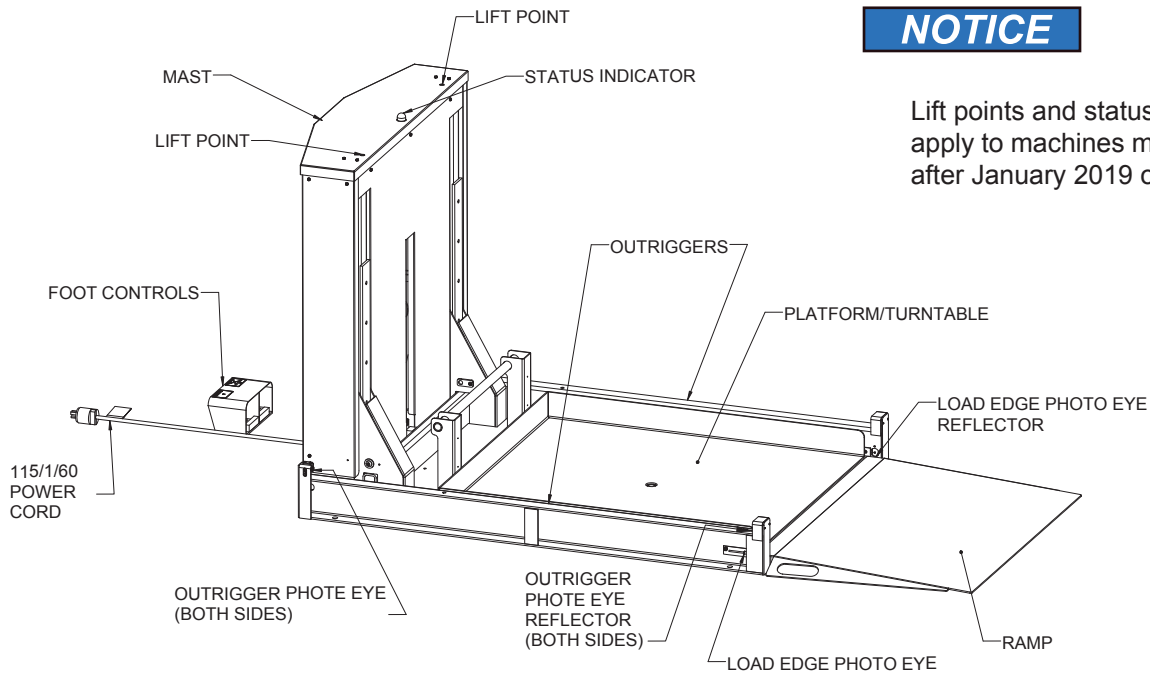

NOTICE

On machines manufactured before February 2019, the turntable position switch striker is a wedge-like block.

12. Warranty & Contact Information

Southworth Products Corp. warrants this product to be free from defects in material or workmanship for the duration of the warranty period. Warranty periods vary and begin on the date of shipment. For specific warranty information, contact Southworth Products with the machine's serial number.

Any claim for breach of this warranty must be received in writing by Southworth within the warranty period. Warranties shall not cover failure or defective operation caused by misuse, misapplication, negligence or accident, exceeding recommended capacities, or any alteration or repair of the item purchased which has not been authorized by Southworth. Except as set forth herein, Southworth makes no other warranties, express or implied, including THE WARRANTIES OF MERCHANTABILITY AND OF FITNESS FOR A PARTICULAR PURPOSE, all of which ARE HEREBY EXCLUDED.

Southworth meets the labeling requirements of California's Proposition 65. Southworth makes no warranty or representation with respect to the compliance of any product with other State or local safety or product standard codes and any failure to comply with such codes shall not be considered a defect of material or workmanship under this warranty. Southworth shall not be liable for any direct or consequential damages arising out of such non-compliance.

Southworth's obligations under any warranty or for any other damages which may arise under any sale, agreement, or contract, are limited to the replacement or repair of defective components at its factory or another location at Southworth's discretion. This is buyer's sole remedy under any such warranty, sale, agreement, or contract. Southworth will not be liable for consequential, incidental, exemplary, or punitive damages of any kind resulting from a breach of any warranty that it has provided or for breach of any term of any sale, agreement, or contract. Any warranty may be altered only in writing by Southworth.

SOUTHWORTH

SOUTHWORTH PRODUCTS CORP.
P.O. Box 1380, Portland, ME 04104-1380
Telephone: 800-743-1000 • 207-878-0700
Fax: 207-797-4734

www.SouthworthProducts.com