

SOUTHWORTH

Owner's Manual LSH Series Lift Tables



Model # _____

Serial # _____

Placed in Service _____

Southworth Products Corp

P.O. Box 1380 Portland, Maine 04104-1380

Telephone 800-743-1000 or 207-878-0700 Fax 207-797-4734

www.SouthworthProducts.com

Please note: This manual was current at the time of printing. To obtain the latest, most updated version, please contact Southworth's Customer Service Department or go to our website: www.SouthworthProducts.com, under Parts & Service/Online Manuals. You will find a complete list of current owner's manuals to print.

CONTENTS

INTRODUCTION	4
RESPONSIBILITY OF OWNERS AND USERS	5
SAFETY ALERT SYMBOLS AND SIGNAL WORDS.....	6
SAFE SERVICING	7
SAFETY PRECAUTIONS.....	8
INSTALLATION INSTRUCTIONS	8
Preparation	8
Positioning the Lift	9
Hydraulic Connections	10
Electrical Connections.....	10
Completing Installation	11
OPERATING INSTRUCTIONS	14
Labels and Precautionary Markings	13
Operating Procedure	14
MAINTENANCE	15
Hazards	15
Routine Periodic Maintenance	15
Repacking Cylinders	16
Replacing Leg Rollers	16
Troubleshooting Check List & Warnings.....	18-19
ORDERING REPLACEMENT PARTS	20
2 YEAR WARRANTY	26

List of Figures

Figure 1	Safe Servicing of Lift	7
Figure 2	Mount the Lift Securely	8
Figure 3	Using Lifting Eyes	9
Figure 4	Center the Load	11
Figure 5	Secure the Load	11
Figure 6	Labels & Precautionary Markings	13
Figure 7	Pinch Points	14
Figure 8	J-Style Cylinder	17
Figure 9	Parts Identification	21
Figure 10	Hydraulic Pump and Down Valve	22
Figure 11	Electrical Connections, Lifts Wired for Single-Phase AC	22
Figure 12	Wiring Diagram, Lifts Wired for Single-Phase AC with limitswitch	23
Figure 13	Electrical Connections, Lifts Wired for Three-Phase AC	23
Figure 14	Schematic, Lifts Wired for Three-Phase AC	24
Figure 15	Hydraulic Connections	24
Figure 16	Hydraulic Diagram	25
Table 1	Hydraulic Oil Specifications	10
Table 2	Electrical Interface, Supplied by Customer	25

INTRODUCTION

Southworth's LSH series is our basic line of "high lift" hydraulic lift tables. These lifts all have two or more sets of scissors legs. The basic LSH series lift may be modified in many ways to meet special requirements for load capacity, vertical travel, table size, power source, and other characteristics. LSH lifts can also be fitted with many optional accessories and modifications to suit the customer's needs.

This manual contains information to acquaint you with the safe and proper installation, use, and upkeep of an LSH series lift table. You should ensure that this manual is available to personnel working with and on the lift table and require its use by these personnel.

LSH lift tables are designed for lifting and vertical positioning of equipment and materials in a wide variety of industrial settings. The instructions set forth in this manual are not necessarily all-inclusive, as Southworth cannot anticipate all conceivable or unique situations. **In the interest of safety, please read all of this manual carefully, and be familiar with its contents before you install, use, or service the LSH Lift Table. If you have any questions about any of the instructions in this manual, please contact your dealer or Southworth Products Corp.**

Southworth's product warranty is shown on the back cover of this manual.

This instruction manual is **not intended to be or to create any other warranty, express or implied, including any implied warranty of merchantability or fitness for a particular purpose, all of which are hereby expressly excluded.**

As set forth more specifically in the product warranty, Southworth's obligation under that warranty is **limited** to the repair or replacement of defective components, which shall be the buyer's **sole remedy**, and Southworth shall not be liable for any loss, injury, or damage to persons or property, nor for any direct, indirect, or consequential damage of any kind resulting from the LSH lift table.

Responsibility of Owners and Users

Inspection and Maintenance

The device shall be inspected and maintained in proper working order in accordance with Southworth's owner's manual.

Removal from Service

Any device not in safe operating condition such as, but not limited to, excessive leakage, missing rollers, pins, or fasteners, any bent or cracked structural members, cut or frayed electric, hydraulic, or pneumatic lines, damaged or malfunctioning controls or safety devices, etc. shall be removed from service until it is repaired to the original manufacturer's standards.

Deflection

It is the responsibility of the user/purchaser to advise the manufacturer where deflection may be critical to the application.

Repairs

All repairs shall be made by qualified personnel in conformance with Southworth's instructions.

Operators

Only trained personnel and authorized personnel shall be permitted to operate the lift.

Before Operation

Before using the device, the operator shall have:

- Read and/or had explained, and understood, the manufacturer's operating instructions and safety rules.
- Inspected the device for proper operation and condition. Any suspect item shall be carefully examined and a determination made by a qualified person as to whether it constitutes a hazard. All items not in conformance with Southworth's specification shall be corrected before further use of the equipment.

During Operation

The device shall only be used in accordance with this owner's manual.

- Do not overload.
- Ensure that all safety devices are operational and in place.

Modifications or Alterations

Modifications or alterations to any Southworth industrial positioning equipment shall be made only with written permission from Southworth.

SAFETY ALERT SYMBOLS AND SIGNAL WORDS

The safety of all persons operating, maintaining, repairing, or in the vicinity of this equipment is of paramount concern. This is a powerful machine with moving parts, and is capable of causing personal injury if proper precautions are not taken. Therefore, throughout this manual, certain hazards have been identified which may occur in the use of the machine, and there are appropriate instructions or precautions which should be taken to avoid these hazards. In some cases, there are consequences which may occur if instructions or precautions are not followed. Below are the symbols and signal words along with their definitions referenced from ANSI Z535.4 - Product Safety Signs and Labels.

4.11 Safety Alert Symbols: A symbol that indicates a hazard. It is composed of an equilateral triangle surrounding an exclamation mark. The safety alert symbol is only used on hazard alerting signs. It is not used on safety notice and safety instructions signs.



A): for use with DANGER signal word; (safety white triangle, safety red exclamation mark, safety red background)

B): for use with WARNING signal word; (safety black triangle, safety orange exclamation mark)

C): for use with CAUTION signal word; (safety black triangle, safety yellow exclamation mark)

D) and E): for use with DANGER, WARNING, or CAUTION signal word; (D: is a safety yellow triangle with a black border and safety black exclamation mark; E: is a safety yellow triangle with a safety black exclamation mark and a safety yellow border around a safety black band)

NOTE: D and E are provided to allow for consistency with certain ISO standards such as ISO 3864-1 and ISO 3864-2.

4.14 Signal Words: The words used in the signal word panel. The signal words for hazard alerting signs are “DANGER,” “WARNING,” and “CAUTION.” Safety notice signs use the signal word “NOTICE.” Safety instruction signs use signal words that are specific to the situation.



DANGER indicates a hazardous situation which, if not avoided, will result in death or serious injury.



WARNING indicates a hazardous situation which, if not avoided, could result in death or serious injury.



CAUTION indicates a hazardous situation which, if not avoided, could result in minor or moderate injury.



NOTICE is used to address practices not related to physical injury.



SAFETY INSTRUCTIONS (or equivalent) signs indicate specific safety-related instructions or procedures.

NOTE: DANGER, WARNING or CAUTION should not be considered for property damage accidents unless personal injury risk appropriate to these levels is involved.

SAFE SERVICING OF THE LIFT

⚠️ WARNING

Only authorized personnel should perform inspection or maintenance and service procedures. Unauthorized personnel attempting these procedures do so at the risk of severe injury or death.

DANGER !

Failure to properly adhere to lift blocking procedures is to risk the sudden and uncontrolled descent of the lift during maintenance or inspection. A falling lift can cause severe injury or death.

This procedure describes the only factory-approved method of working under a lift. Follow these instructions **EVERY** time you plan to reach or crawl beneath the lift to perform service or maintenance – no matter how momentary that might be.

If the factory-provided maintenance device is damaged or missing, stop immediately and consult the factory for assistance. The manufacturer is not liable for your failure to use the approved maintenance device(s) and procedures that have been provided.

1. Any load must be removed from the lift prior to engaging the maintenance device(s). These devices are designed to support an unloaded lift only. Failure to remove the load from the lift prior to blocking could cause the failure of the maintenance device(s) and allow the lift to fall unexpectedly. This can result in personal injury or death, or permanent damage to the maintenance device(s) and/or the lift.
2. Raise the lift to its fully raised position. If you do not, the maintenance device(s) may not be able to be placed properly in its/their designed blocking position.
3. Remove the maintenance device(s) from its/their storage location and place it/them into the engaged position as shown in Figure 1.
4. Lower the lift until it makes complete contact with the maintenance device(s). Re-check to ensure that all provided devices are fully and securely engaged. If the device(s) is/are not fully engaged the lift could fall unexpectedly, resulting in permanent damage to the device(s) or the lift.

⚠️ DANGER

If for any reason you are unable to lower the lift completely onto the maintenance device(s), stop immediately and consult the factory. Failure to properly use the factory approved maintenance device(s) could result in severe injury or death.

5. (For single-acting hydraulic, and pneumatic lifts) Once the maintenance device(s) is/are properly and securely engaged, continue to press the down button, valve or switch for an additional 5-10 seconds to relieve all pressure in the operating system.

⚠️ WARNING

Failure to relieve operating system pressure could result in the sudden and unexpected release of high pressure fluids (or air) during maintenance and/or repair of the lift and result in severe injury or death.

6. Follow OSHA electrical lock-out/tag-out procedures. Disconnect and tag all electrical and/or other power sources to prevent an unplanned or unexpected actuation of the lift.
7. Once inspection or work is complete, reverse the performance of the steps above to raise the lift off the maintenance device(s) and place the device(s) back into its/their designated storage position(s).

⚠️ DANGER

HIGH VOLTAGE ! – Disconnect and/or lock out the electrical supply to the power unit prior to any installation or maintenance being performed.

Fig. 1 – Safe Servicing of Lift

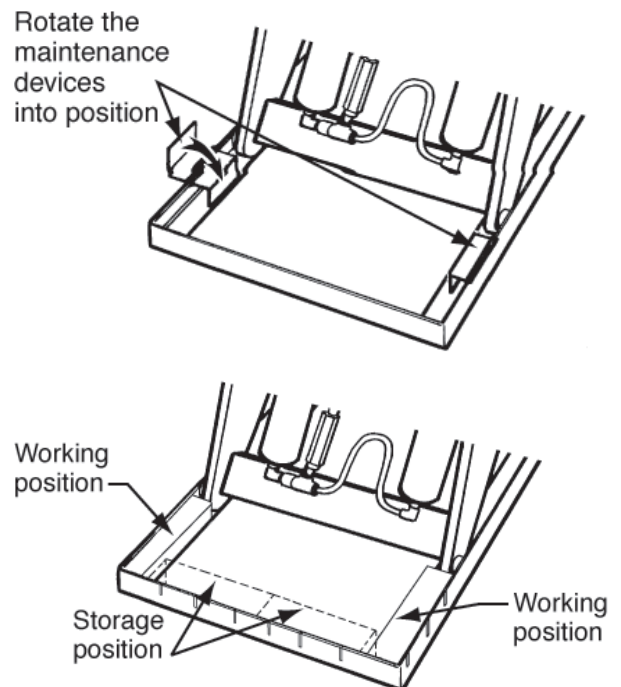

SAFETY

The safety of all persons operating, maintaining, repairing, or in the vicinity of the LSH lift table is of paramount concern to Southworth. The lift table is a powerful machine with moving parts, and is **capable of causing personal injury if proper precautions are not taken**.

Therefore, throughout this manual, Southworth has identified certain hazards which may occur in the use of the lift table, and provided appropriate **instructions** or **precautions** which should be taken to avoid these hazards.

In some cases, Southworth has also pointed out the **consequences** which may occur if Southworth's instructions or precautions are not followed. Southworth uses the following system of identifying the severity of the hazards associated with its products:

⚠ DANGER Immediate hazard which will result in severe personal injury or death.

⚠ WARNING Hazard or unsafe practice which could result in severe personal injury or death.

⚠ CAUTION Hazard or unsafe practice which could result in minor personal injury or property damage.

Please read and follow this instruction manual, including all safety instructions and precautions, carefully and completely.

INSTALLATION INSTRUCTIONS

Preparation

1. Before you start to install the lift, check for local codes and ordinances which may apply. It is your responsibility to obtain any necessary permits.
2. **Read all of these installation instructions carefully. Be sure to read and understand all of the warnings!**
3. If your unit is designed to be installed in a pit, check the pit before you start to install the lift. Measure the length and width of the lift table, then measure the pit, and be sure the pit allows adequate clearance. Does the pit have 90° angles at each corner? To check, measure across the opposite corners of the pit. The measurement on each diagonal should be the same, within 1/2 inch. The walls of the pit should be vertical. Check with a carpenter's square.
4. If the power unit will be mounted away from the lift ("external power unit"), check the mounting arrangement for the power unit. The power unit should be sheltered from the weather. It should be mounted within 30 feet of the lift to minimize the pressure drop in the hydraulic system. Be sure the hydraulic lines have been installed properly.

⚠ WARNING

Protect the power unit from rain or moisture. If the electrical parts in the power unit get wet,

Fig. 2 – Mount the Lift Securely

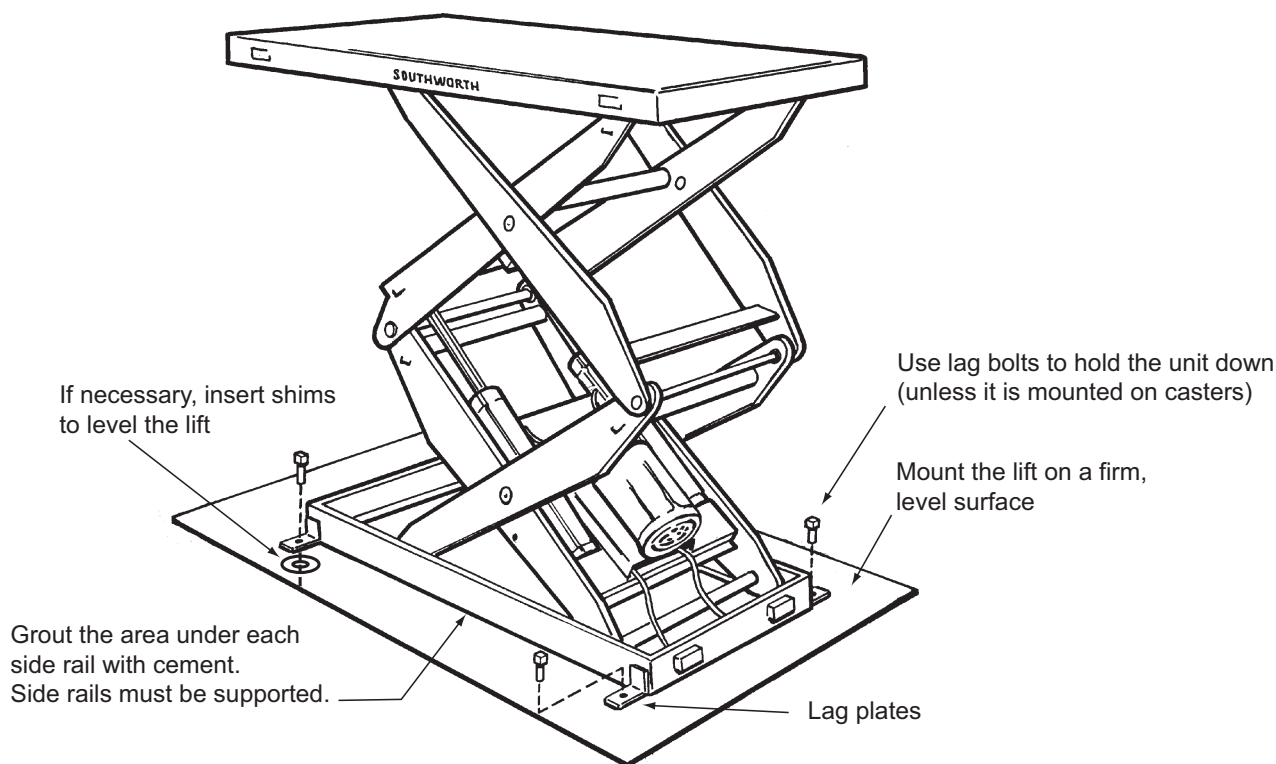
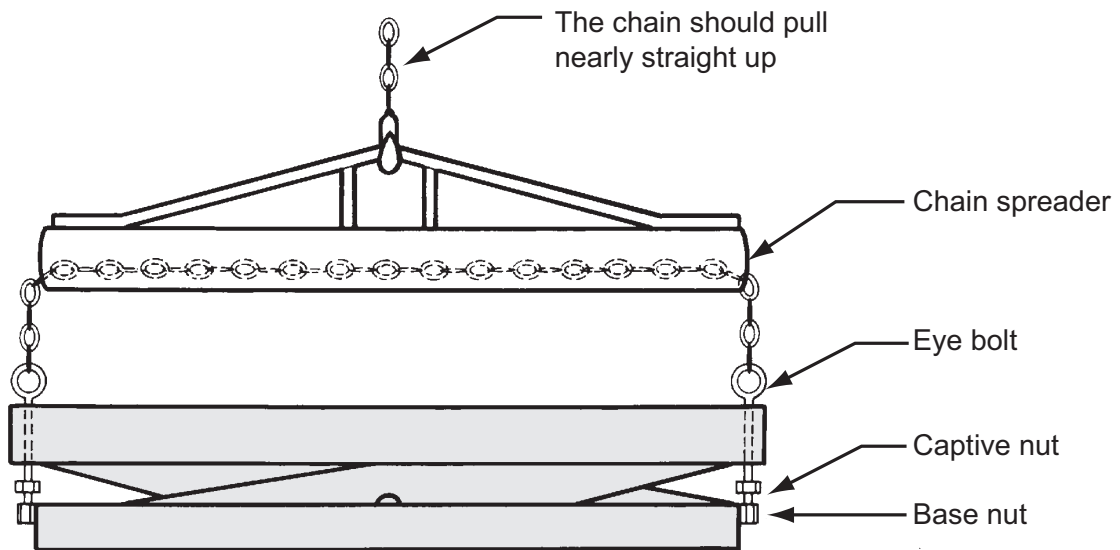

Fig. 3 – Using Lifting Eyes



workers may be hurt by electrical shock. The electrical parts may fail if they are wet.

⚠WARNING

The electric motor in the lift can create sparks. Don't install the power unit in an area where flammable gases may be present.

5. If the power unit is mounted within the lift ("internal power unit"), you will need these tools:

- A crane or lift truck that can lift the unit safely.
- Shims and lag bolts – see the pit plan if the lift will be mounted in a pit.
- A masonry drill and bit to drill the holes for the lag bolts.
- A power supply with the specified voltage, including fuses or circuit breakers as specified in Figs. 11 and 12.

If the power unit will be mounted away from the lift ("external power unit"), you will also need:

- A compressed air source for clearing the hydraulic lines.
- Extra hydraulic oil for flushing the underground lines and refilling the tank. See Table 2 for the oil specifications.

Positioning the Lift

6. Remove the shipping material and unskid the lift. On the front of this manual, confirm the model number, serial number, and date the lift is placed in service. You can find the model number and serial number on the name plate. The name plate is located on the crossbar at the base of the cylinders.

7. Move the lift into position, supporting the base of the lift. Install the lift as shown in Fig. 2. Unless the lift is mounted on casters, lag the lift to the floor.

⚠CAUTION

Do not hang the lift from the table top. This can damage the lift.

⚠WARNING

If the lift is mounted on an unstable surface, it may tip over when it is in use. You may be hurt, and the lift and load may be damaged.

If your lift has lifting eyes, as shown in Fig. 3, use these when you move the lift. It is best to use a chain spreader, so the chain sections pull straight up. (You must supply the chain and spreader.) Remove the lifting eyes once you have moved the lift.

Hydraulic Connections

(External Power Units Only – If Internal Power Unit, proceed to step 10.)

8. Install the power unit. Install the hydraulic line between the power unit and the lift as shown on the pit plan.

9. Blow out the hydraulic line with compressed air before connecting it to the power unit. Replace the solid plug on the hydraulic fluid tank with the vented plug supplied, then attach the vent line to the vented plug.

⚠WARNING

Be sure that the hydraulic line will not be pinched by the lift as it raises or lowers. If you allow the line to be pinched, the lift may not work properly. A hose may break, the lift table may drop suddenly, and someone may be hurt.

⚠ CAUTION

It is very important to keep the hydraulic oil free of dirt, dust, metal chips, water, and other contamination. Most of the problems with hydraulic systems are caused by contamination in the oil. Be sure to flush all hydraulic lines before connecting remote power units.

⚠ CAUTION

If you do not install the vented plug in the tank, the pump may be damaged.

Electrical Connections

⚠ DANGER

The lift may use a power supply of up to 575 Volts AC. This voltage can kill you. Don't work with the electrical parts unless you are a qualified electrician.

10. Make temporary electrical connections to the lift, as shown in Fig. 11 (for single-phase AC) or Fig. 12 (for three-phase AC). This temporary set-up will allow you to raise the lift.

⚠ WARNING

The fusing requirements are shown in Table 1. To avoid fire danger, follow these requirements.

11. On a lift designed for three-phase AC, you must be sure the pump motor is turning in the right direction. The lift table should start to move quickly when you press the

“up” or “down” button. If the lift table does not move in 2 or 3 seconds, don't try to operate the lift! Exchange any two of the three-phase leads. If this does not correct the problem, see the troubleshooting instructions at the end of this manual.

⚠ CAUTION

If you have a unit designed for three-phase AC and you connect the power so the motor runs backwards, the lift will not operate, and you may damage the pump. Do not operate the lift for more than 2 or 3 seconds if you think the motor might be turning backwards.

- 12. **Raise and chock the lift**, as shown in Fig. 1.
- 13. Make the permanent electrical connections as shown in Fig. 11 (for single-phase) or Fig. 12 (for three-phase).
- 14. Check the level of the hydraulic fluid. On most models, when the lift is fully elevated, the oil should be about 3/4 inch above the bottom of the tank. Use a dipstick to check the oil level, and add oil as necessary.

Testing

- 15. Clear the area around the lift. Remove any loose wires, lumber, or other materials which might get in the way of the lift as it raises or lowers.
- 16. Remove the maintenance chocks and warn others to stay away from the lift. Operate the lift through its full range of travel. The lift should rise smoothly with a quiet humming sound, and lower smoothly and quietly. Raise and lower the lift a few times to check the clearances around the lift table.

Table 1 – Hydraulic Oil Specifications

If the lift will be used at normal ambient temperatures, Southworth supplies the unit with CONOCO 32 oil. This may be replaced by any other good quality oil with 150 SSU at 100° F and rust and oxidation inhibitors and anti-wear properties.

If the lift will be used at ambient temperatures below 0°F, use aircraft hydraulic oil. Use Type 15 aircraft hydraulic oil.

The following are equivalent to CONOCO 32:

TYPE	MANUFACTURER
DTE 24	EXXON/MOBIL
NUTO H32	EXXON/MOBIL
AMOCO AW32	CHEVRON (AMOCO CO.)

⚠ CAUTION

It is very important to keep the hydraulic oil free of dirt, dust, metal chips, water, and other contamination. Most of the problems with hydraulic systems are caused by contamination in the oil.

⚠WARNING

As the lift table moves up and down, “pinch points” are created at the places shown in Fig. 6. If you are standing too close to the lift when it is moving, your arm or leg may be caught in the moving parts, and you may be hurt. Stay away from the pinch points when the lift is moving.

Completing Installation

17. If your lift is mounted in a pit, align the unit with the sides of the pit. Once you are sure the lift is positioned correctly, mark the locations of the lag holes in the base frame, and drill the holes. If necessary, insert metal shims to level the base of the lift. Insert and tighten the lag bolts to secure the lift. Grout under the base rails to prevent vibration and distortion of the base frame, as shown in Fig. 2.

18. If the lift is lowering too quickly or too slowly, you can change the “down speed” by adjusting the flow control.

⚠WARNING

When adjusting the flow control, always raise the lift table and insert the maintenance chocks, as shown in Fig. 1. Don't try to adjust the flow control while pressing the “down” button. If you try this, the lift table may drop suddenly, and you may be hurt.

It is important that you follow these steps when adjusting the flow control:

- **Raise the lift table and chock the legs**, as shown in Fig. 1.
- If you want the lift to lower more slowly, turn the control clockwise up to 1/4 turn at a time. If you want the lift to lower more quickly, turn the control counterclockwise up to 1/4 turn. Don't move the control more than 1/4 turn at a time.
- Remove the maintenance chocks, and check the descent speed.
- Every time you want to change the adjustment again, raise the table again and insert the chocks as shown in Fig. 1.

19. Test the lift with the rated load. If the lift does not rise, and you hear a loud squealing noise, the pressure relief valve is operating. Contact Southworth for instructions.

⚠WARNING

Don't continue to use the lift if this happens. The pump will overheat very quickly, and may be permanently damaged. Do not try to adjust the relief valve. If you change the setting on the relief valve, you may overwork the lift. This can cause the lift to fail suddenly, and you may be hurt.

20. As a final step, clean up all spilled hydraulic fluid. Spilled hydraulic oil is slippery, and may present a fire hazard. If you clean up any spilled fluid, you will be able to tell immediately if the lift begins to leak.

Fig. 4 – Center the Load

Always place the load in the center of the lift table

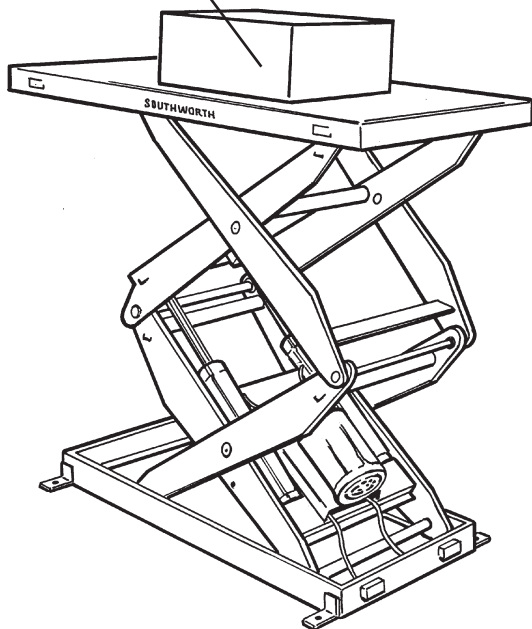
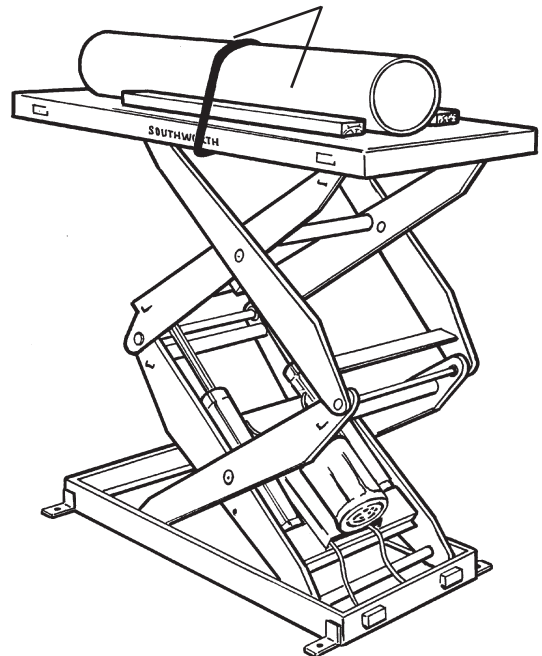

Fig. 5 – Secure the Load

If the load can roll or move, insert chocks, or fasten the load down



OPERATING INSTRUCTIONS

Operating Procedure

1. Before operating the lift, read and understand this entire section. Also read and understand the inserted information on optional modifications and accessories.

⚠ DANGER

The lift may use a power supply of up to 575 Volts AC. This voltage can kill. Don't work with the electrical parts unless you are a qualified electrician!

2. If the lift is on casters, place it on a firm, flat surface as shown in Fig. 2. Stationary lifts should be lagged to the floor.

⚠ WARNING

If you place the lift on a soft surface, it may tip over, especially when it is loaded or raised. Someone may be hurt, and the lift and load may be damaged.

3. Load the lift correctly.

- Be sure that the load weighs no more than the maximum rated for the lift. The maximum rated load is shown on the platform skirt.

⚠ WARNING

Don't try to lift a load that exceeds the maximum rating. If you try this, the lift may fail suddenly. Someone may be hurt, and the lift and load may be damaged.

- Place the load in the center of the lift table, as shown in Fig. 4.
 - Don't try to load the lift while the lift table is moving.
 - If you are lifting pipes or other objects which may be able to roll or move, fasten them down, or chock them as shown in Fig. 5.
4. Be sure all workers are clear of the lift. Remove any lumber or other material which may fall onto the lift.

⚠ WARNING

Don't use the unit to lift people unless it has been specially equipped for this purpose. A specially equipped lift will include operator protection, and an excess flow protector to keep the lift from dropping suddenly if a hydraulic line is damaged. Retrofit kits are available if you want to add these features to your lift.

⚠ WARNING

As the lift table moves up and down, "pinch points" are created as shown in Fig. 6. Stay away from these pinch points! Part of your body or clothing may become caught, and you may be hurt.

5. Operate the lift. Press and hold the "up" button to raise the lift, and "down" to lower it. Release the button when the lift reaches the limit of travel. If the lift does not operate within 2 or 3 seconds, turn off the lift and call a qualified maintenance worker.

⚠ WARNING

If you hear a squealing noise from the pump, the pressure relief valve is operating. Don't continue to use the lift! The pump will overheat very quickly, and may be permanently damaged. The relief valve is included to protect the machine operators – don't change the relief pressure setting.

6. Wait until the lift table has stopped. Unload the lift.

⚠ WARNING

The warning labels on the lift are there for your safety. If you find that the labels are worn or missing, or have been painted over, ask Maintenance to replace the labels before you use the lift. The labels are shown in Fig. 7.

Fig. 7 – Pinch Points

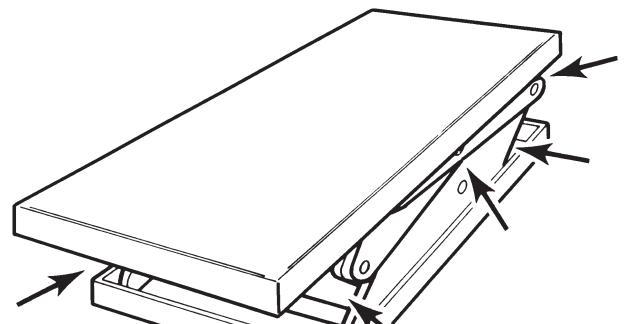
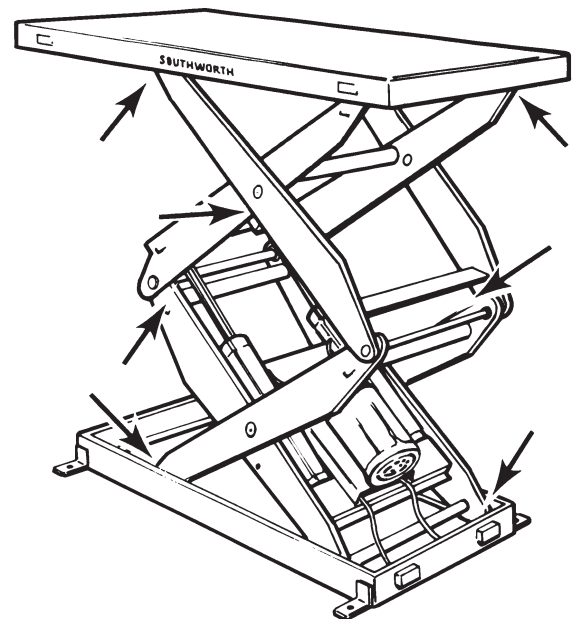

MAINTENANCE

All servicing should be done by qualified personnel. Qualified personnel should be able to read and understand wiring and hydraulic diagrams. They should be able to troubleshoot live electrical circuits safely and in accordance with accepted practice. For safety's sake, if in doubt, please contact your dealer or Southworth Products Corporation Customer Service Department at (207) 878-0700 or (800) 743-1000.

Before servicing the lift, read and understand this entire section and the section entitled "Operating Instructions." Also read and understand the inserted information on optional modifications and accessories.

Hazards

There are several hazards you should be aware of as you service the lift:

⚠ DANGER

The lift may use a power supply of up to 575 Volts AC. This voltage can kill. Don't work with the electrical parts unless you are a qualified electrician!

⚠ WARNING

- As the lift moves up and down, "pinch points" are formed as shown in Fig. 6. Keep hands, feet, and loose clothing away from these pinch points. If your hand or arm or a part of your clothing is caught, you may be hurt.
- A falling lift can cause severe personal injury. Before working under the lift, raise the lift and insert the maintenance chocks, as shown in Fig. 1. Do this every time you work under the lift!
- This power unit contains a hydraulic pump that is capable of developing excessive pressure. A pressure relief valve is used to set the pressure at the desired level. Tampering with, adjusting, modifying, or removing the relief valve is extremely dangerous and is not recommended. Only a trained hydraulics technician, using a calibrated hydraulics pressure gauge to assure the proper pressure setting is achieved, should make adjustments to the relief valve.
- Release of fluids under high pressure can cause personal injury. Before you open any part of the hydraulic system, be sure to release the hydraulic pressure.
- The warning labels on the lift are there for the safety of the operators. See Fig. 7.
- If the labels are worn or missing, or have been painted over, replace them before releasing the lift for operation.

TROUBLESHOOTING WARNINGS

All servicing should be done by qualified personnel. Qualified personnel should be able to read and understand wiring and hydraulic diagrams. They should be able to troubleshoot live electrical circuits safely and in accordance with accepted practice. **For safety's sake**, if in doubt, please contact your dealer or Southworth Products Corp. Before servicing the lift, **read and understand this entire section and the section entitled "Operating Instructions."**

⚠ WARNING

Before working underneath the lift, always raise the lift and insert the maintenance devices, as shown in Figure 1. Failure to do so may result in damage to the lift and severe personal injury!

If the lift will not raise:

⚠ CAUTION

Do not continue to hold the "up" button for more than 2 or 3 seconds. You may damage the pump.

⚠ WARNING

Do not change the relief valve setting. This valve has been included for the protection of workers who install, use, or service the lift. If it is ever necessary to repair or reset the valve, contact Southworth Products Corp. for instructions.

Do not disconnect the up limit switch. Instead, loosen the adjusting screw, and change the position of the arm. If you do disconnect the switch, when the lift platform moves up, it may not stop at the correct point. If the platform rises above the normal stopping point, the frame of the unit may be damaged. People working nearby may be hurt.

⚠ CAUTION

If cavitation is allowed to continue, the pump may be damaged, and may have to be replaced.

If the lift elevates, but fails to hold a load:

⚠ WARNING

Failure to insert the maintenance devices may result in damage to the lift and severe personal injury!

If the lift fails to lower:

Failure to insert the maintenance devices may result in damage to the lift and severe personal injury!

⚠ DANGER

Do not try to adjust the flow control while pressing the "down" button. If you try this, the lift table may drop suddenly, and you may be hurt.

Routine Periodic Maintenance

Suggested Preventative Maintenance Schedule (ensure that lift is properly chocked as required.)

Weekly	Inspect leg rollers, center pivot pins and bushings, leg hinge pins and bushings for evidence of wear. loose bolts or broken cotter pins or keepers. Repair or replace as required.
Monthly	Apply a light oil or PTFE lubricant to non-greased pivot points or rollers described above.
	Check the appearance of the hydraulic fluid.
	Check all the hydraulic fittings and hoses.
	Make all weekly checks, check limit switch if applicable.
Every 6 months or 500 hours of operation	Check all the hydraulic fittings and hoses, and repair the connections.
	Inspect cylinder return line and rod. Appearance of considerable fluid in the vent lines indicates a need to repack the cylinder.
	Disassemble the down valve. Blow the plunger clean with compressed air. Reassemble and install.
	Change oil in reservoir, clean the suction screen and vent cap. Replace pressure line or return line filter element.
	Make all weekly, and monthly checks, check all electrical connections..
	NOTE: If bushings at the main pivot points are neglected and allowed to oblong, major structural problems will develop and extensive repairs will be needed.
Minimum Required Maintenance for Units with High Cycle Package	Every 10,000 cycles, visually inspect the entire lift. Replace all worn or broken parts. Lubricate all pivot points and clean the roller track.
	Every 30,000 cycles, visually inspect the entire lift. Check the motor starter contacts and limit switches. Clean and lubricate all pivot points. Inspect for worn or broken parts, and replace as necessary.
	Every 90,000 cycles, visually inspect the entire lift. Check the hydraulic tank and the hydraulic lines. Clean and lubricate all pivot points. Inspect for worn or broken parts, and replace as necessary. Repack the cylinder(s), and replace the hydraulic oil and filter.
	NOTE: If lubrication points will not take grease, ensure that the load has been removed from the platform, and ensure the grease fittings are not plugged and will take grease, or the weight of the lift may need to be removed from the greaseable joint. A fork truck or overhead crane may be necessary to remove any weight off of the greaseable joints. Contact Southworth's Service Department for further instructions if the machine is still unable to accept grease.

TROUBLESHOOTING

PROBLEM	POSSIBLE CAUSE	CHECK THIS
Lift will not raise	Weight of load too heavy	Check the actual weight of the load
	Motor not running	Check the main disconnect switch, fuses, and wiring to the motor. A 20 amp, designated braker must be supplied for 115 single phase.
	Motor runing but not moving (three phase)	Swap any two phases
	Hydraulic oil level low	When lift is raised as far as possible, oil level should be 3/4" from bottom of tank. When lift is down, 3/4" from top. Ensure chocks on lift before working under it.
	Lift has reached its upper limit	Upper limit switch may need to be adjusted
	Motor may be "single phasing"	If motor hums but does not turn, check motor wiring and line fuses.
	Motor voltage too low	Supply voltage should be +/- 5% of the rating aor single phase and 10% for 3 phase units.
	Tank vent plugged	If supplied, remove solid plug from tank, insert vent plug.
	Suction filter clogged	Clean suction filter as described in periodic maintenance
	Vacuum leak in suction line	Check all fittings in suction line
	Down valve may be energized	Check wiring to down valve, and solenoid in the valve
	Missing coupling	Check to insure the coupling has been installed between the pump and motor as required by pump, see figure 15.
The lift fails to hold	Down valve may be leaking	Remove down valve and inspect for debris which may be preventing it from closing.
	Down valve may be energized	Check the solenoid in the valve with a volt meter.
	Cylinder may be leaking	Check for oil in cylinder in the vent line.
Lift will not lower	Down valve may be de-energized	Check the solenoid in the valve with a volt meter
	Flow control needs adjustment	Adjust flow control as needed
Lift raises too slowly	Voltage may be low	Check voltage at motor to ensure proper voltage is being supplied
	Foreign material clogging suction filter, breather cap or pressure line	Remove necessary components and clean
	Pump may be overheating due to insufficient oil	Check oil level and oil viscosity
Lift lowers too slowly	Down valve may not be fully open or stuck closed	Remove down valve and clean
	Flow control may need adjustment	Adjust flow control as needed

If the steps listed above do not solve the problem, please call the Southworth's Customer Service Department.

ORDERING REPLACEMENT PARTS

Southworth has carefully chosen the components in your lift to be the best available for the purpose. Replacement parts should be identical to the original equipment. **Southworth will not be responsible for equipment failures resulting from the use of incorrect replacement parts or from unauthorized modifications of the machine.**

Southworth will gladly supply you with replacement parts for your Southworth lift. Key parts are identified in Figures 9 and 10. With your order, please include the model number and the serial number of the lift. You can find these numbers on the name plate, which is located on the crossbar at the base of the cylinder(s). When you are ordering parts for a cylinder, also include the cylinder number. This is stamped on the base of the cylinder housing.

To order replacement parts, please call the Parts Department.

Parts are shipped subject to the following terms:

- FOB factory
- Returns only with the approval of our parts department.
- Payment net 30 days (except parts covered by warranty).
- Freight collect (except parts covered by warranty).
- The warranty for repair parts is 30 days from date of shipment.

Parts replaced under warranty are on a “charge-credit” basis. We will invoice you when we ship the replacement part, then credit you when you return the worn or damaged part, and we verify it is covered by our warranty. Labor is not covered under warranty for Parts orders.

Parts Department

Southworth Products Corp.

Telephone 207) 878-0700 or (800) 743-1000

FAX : (207) 797-4734

repairparts@SouthworthProducts.com

www.SouthworthProducts.com

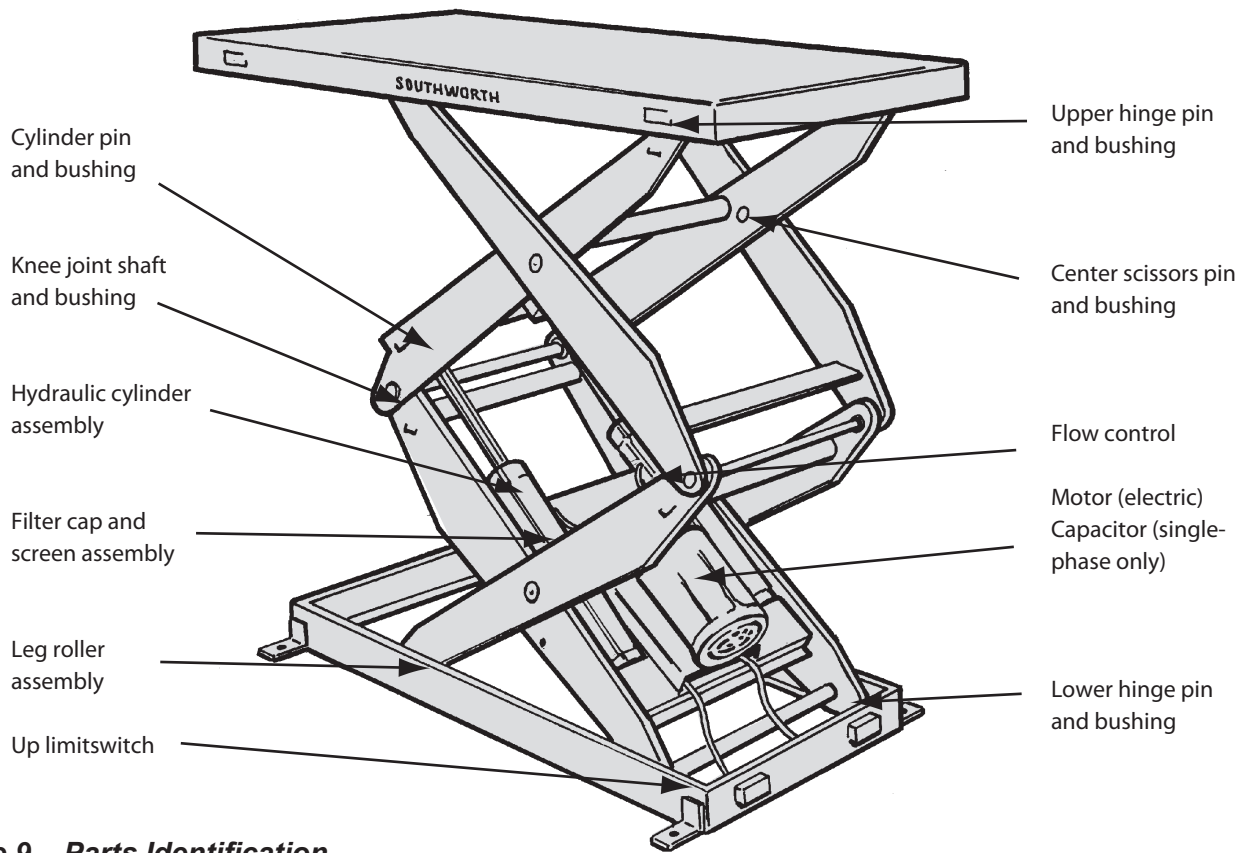
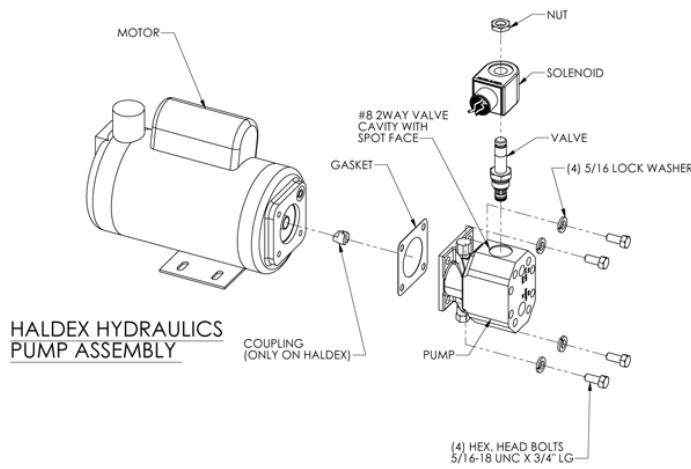
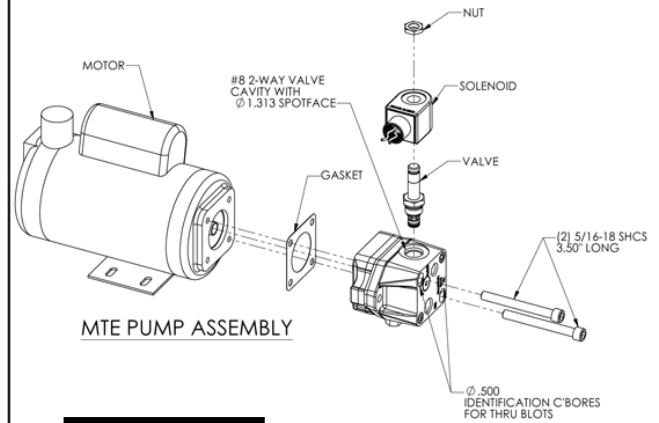
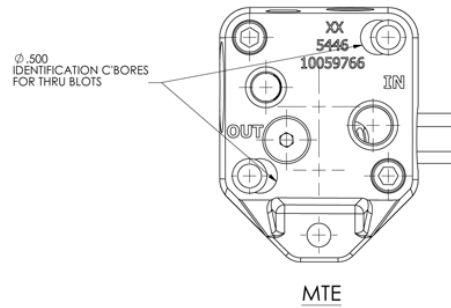

Figure 9 – Parts Identification
 (lift shown without precautionary labels for clarity)

Fig. 10 – Hydraulic Pump and Down Valve



Pre 8/22/2012



Post 8/22/2012

Electrical Connections for Single-Phase AC

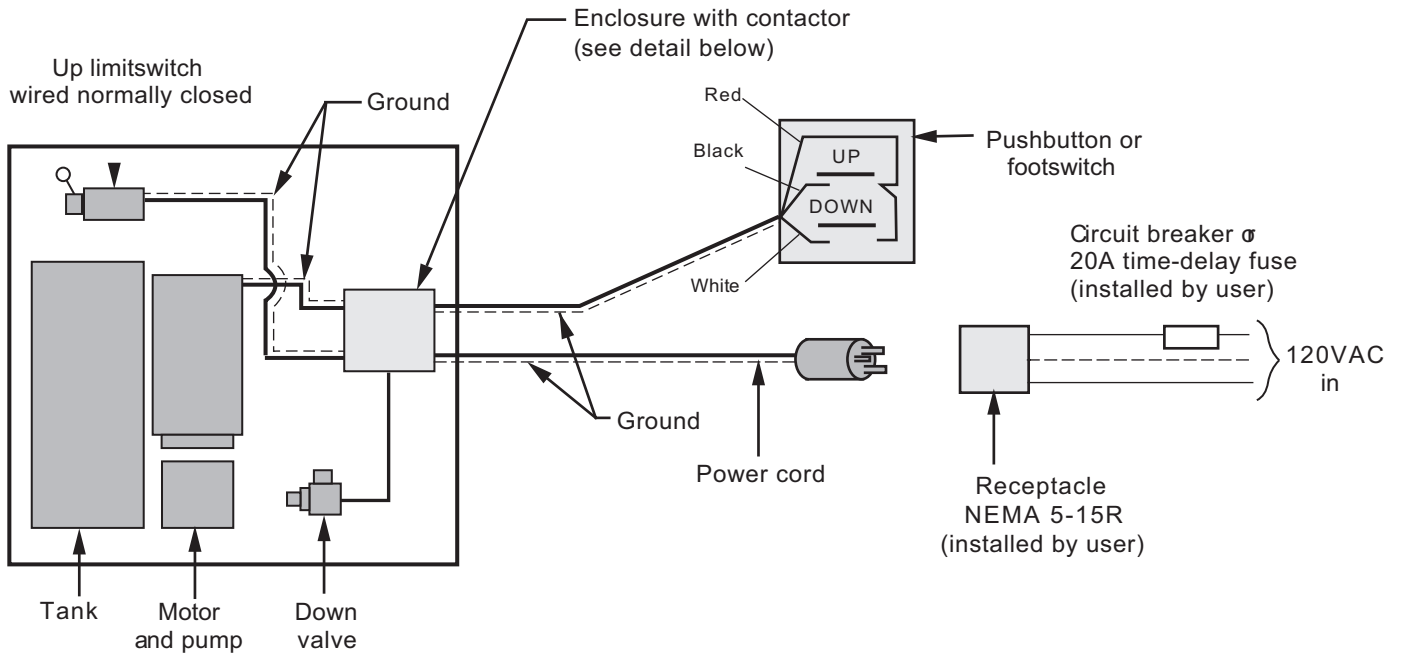
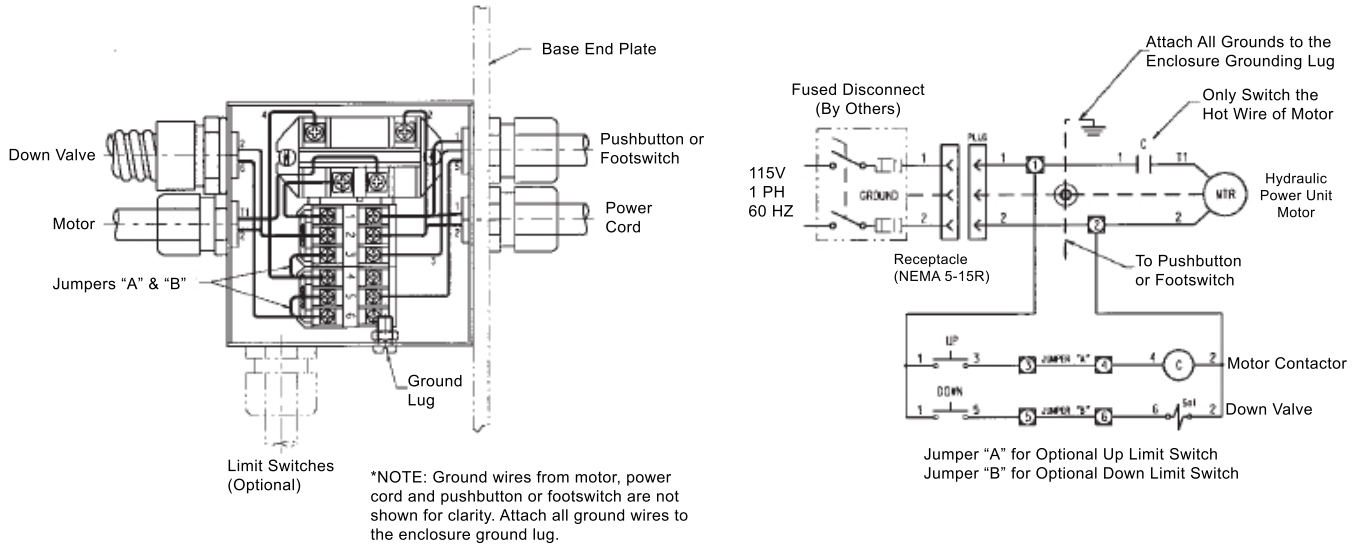

Fig. 11 – Electrical Connections, Lifts Wired for Single-Phase AC

If your lift has a dual-voltage motor, determine the correct voltage and make the connections as shown on the nameplate. Connections shown above are for lifts operating on 120 VAC. For lifts operating on 230 VAC, a NEMA L6-15R receptacle is required. The pump, motor, and down valve may be mounted on the lift unit itself (internal power unit) or in a separate location (external power unit). The pump has a built-in relief valve and check valve. The down speed control is pressure-compensated.

Fig. 12 – Wiring Diagram, Lifts Wired for Single-Phase AC – with limitswitch



Electrical Connections for Three-Phase AC

208/230/460V-3PH60Hz
Supply voltage
(from fused disconnect)

Note: Ground connections not shown.
For ground connections use
supplied grounding terminal.

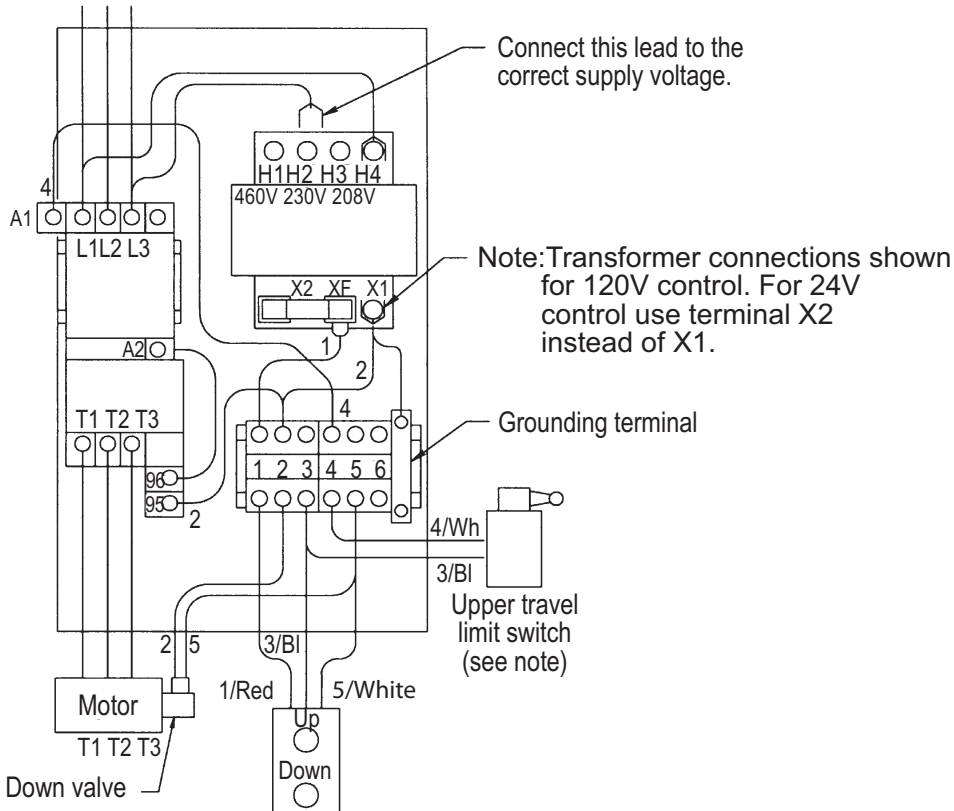
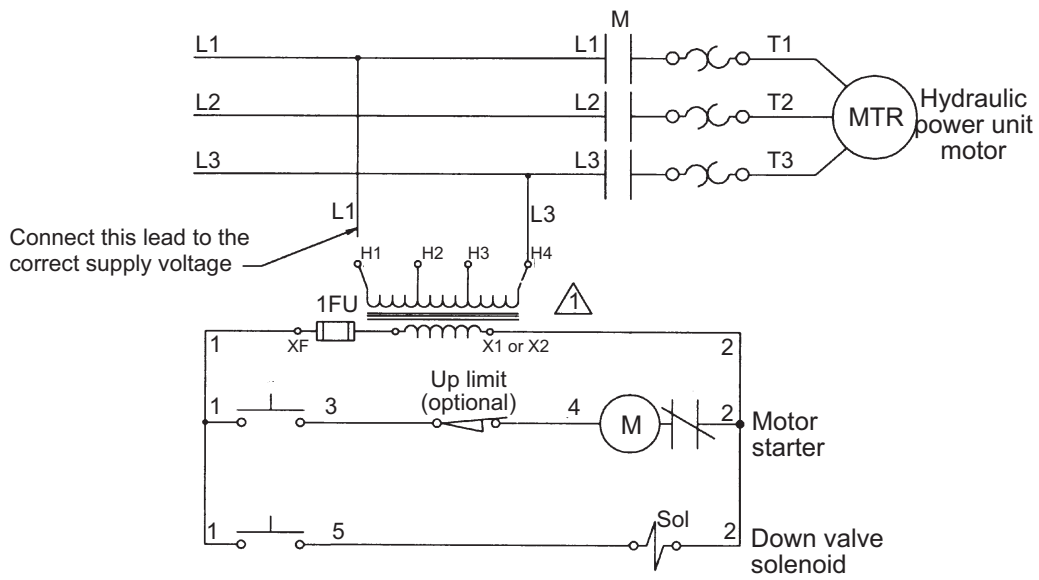

Fig. 13 – Electrical Connections, Lifts Wired for Three-Phase AC

Connect the power and control wiring to the proper terminals located in the control panel. The pump, motor and valve may be mounted on the lift unit itself (internal power unit) or in a separate location (external power unit). The control panel may be wall mounted.

CAUTION!
If on power-up the motor rotates in the wrong direction, don't continue to operate the lift. You may damage the pump. To correct the problem, interchange any two of the motor leads (T₁, T₂ or T₃).

Fig. 14 – Schematic, Lifts Wired for Three-Phase AC



Note: Upper travel limit switch is optional.
If limit switch is absent, move wire 4 in panel from terminal 4 to terminal 3 and renumber as wire 3.

Fig. 15 – Hydraulic Connections

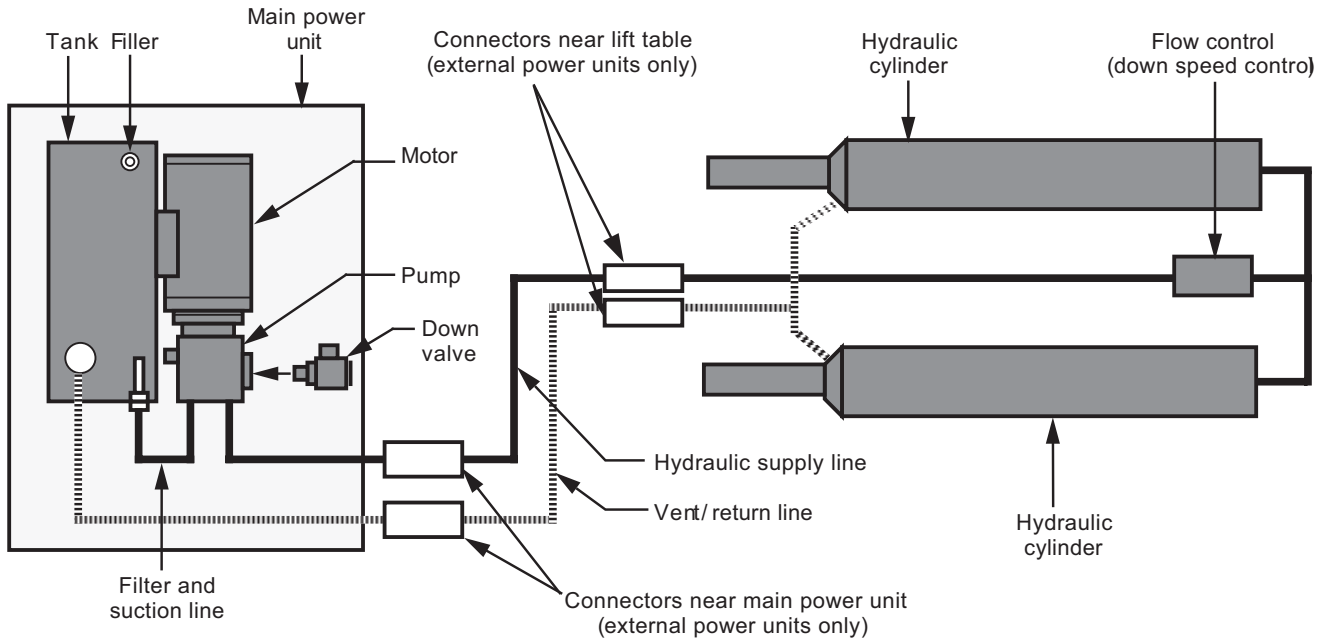

Fig. 16 – Hydraulic Diagram

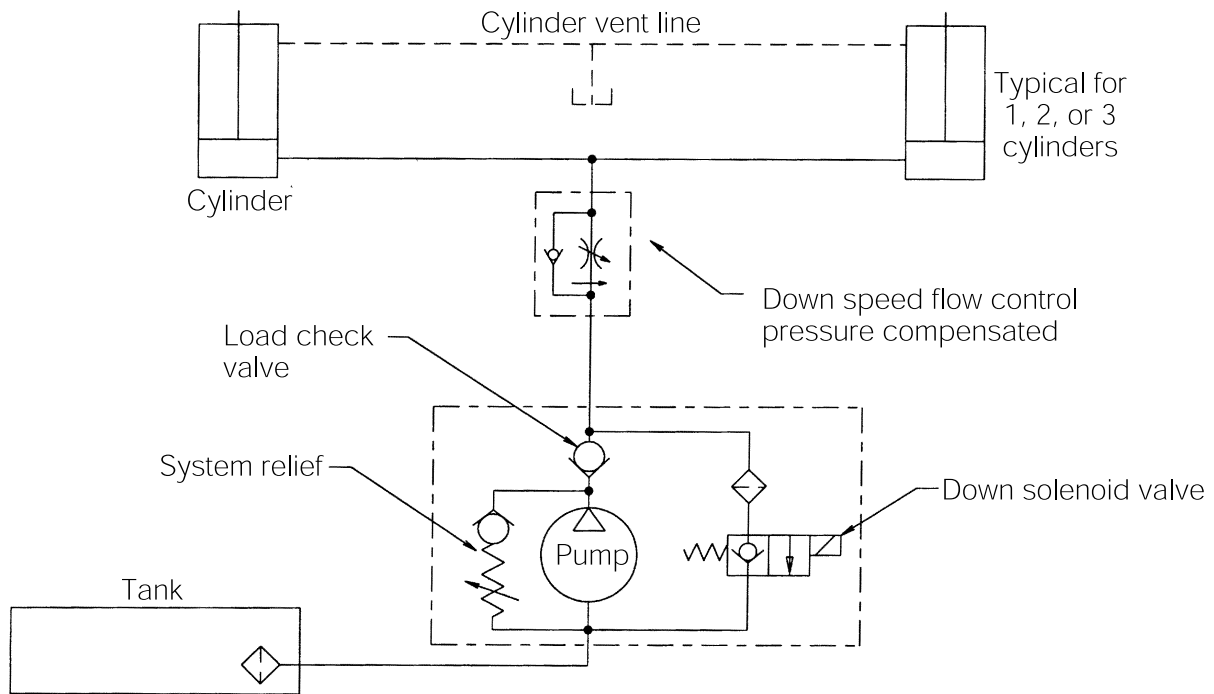

Table 2 – Electrical Interface, Supplied by Customer

Motor Voltage	Required Fuse 1.0 HP Motor	Required Fuse 3.2 HP Motor	Wire Gauge
120/1/60	20 AMP	—	12 AWG
208/1/60	20 AMP	—	12 AWG
240/1/60	20 AMP	—	12 AWG
208/3/60	10 AMP	12 AMP	14 AWG
240/3/60	10 AMP	10 AMP	14 AWG
480/3/60	5 AMP	5 AMP	14 AWG
575/3/60	5 AMP	5 AMP	14 AWG

2 YEAR WARRANTY

Southworth Products Corp warrants this product to be free from defects in material or workmanship for a period of **two years** of single shift usage from date of shipment, providing claim is made in writing within that time period. This warranty shall not cover modified designs for special applications, failure or defective operation caused by misuse, misapplication, negligence or accident, exceeding recommended capacities, failure to perform required maintenance or altering or repairing, unless alteration is authorized by Southworth Products Corp. Except as set forth herein, there are no other warranties, express or implied, including the warranties of merchantability and fitness for a particular purpose, all of which are hereby excluded.

Southworth Products Corp makes no warranty or representation with respect to the compliance of any product with state or local safety or product standard codes, and any failure to comply with such codes shall not be considered a defect of material or workmanship under this warranty. Southworth Products Corp shall not be liable for any direct or consequential damages arising out of such noncompliance.

Southworth Products Corp's obligation under this warranty is limited to the replacement or repair of defective components at its factory or another location at Southworth Products Corp's discretion. The Southworth Warranty is for product sold with in North America. For products shipped outside of North America the warranty will be for replacement of defective parts only. Labor is not included. This is buyer's sole remedy. Except as stated herein, Southworth Products Corp will not be liable for any loss, injury or damage to persons or property, nor for direct, indirect, or consequential damage of any kind, resulting from failure or defective operation of said product.

This warranty may be altered only in writing by Southworth Products Corp, Portland, Maine.

SOUTHWORTH

Southworth Products Corp
P.O. Box 1380, Portland, ME 04104-1380
Telephone: 800-743-1000 / 207-878-0700
Fax: 207-797-4734
www.SouthworthProducts.com