

SOUTHWORTH

All Purpose Container Unloader

For third generation stand-alone machines and second generation Lockheed-Martin APPS Systems replacement machines.

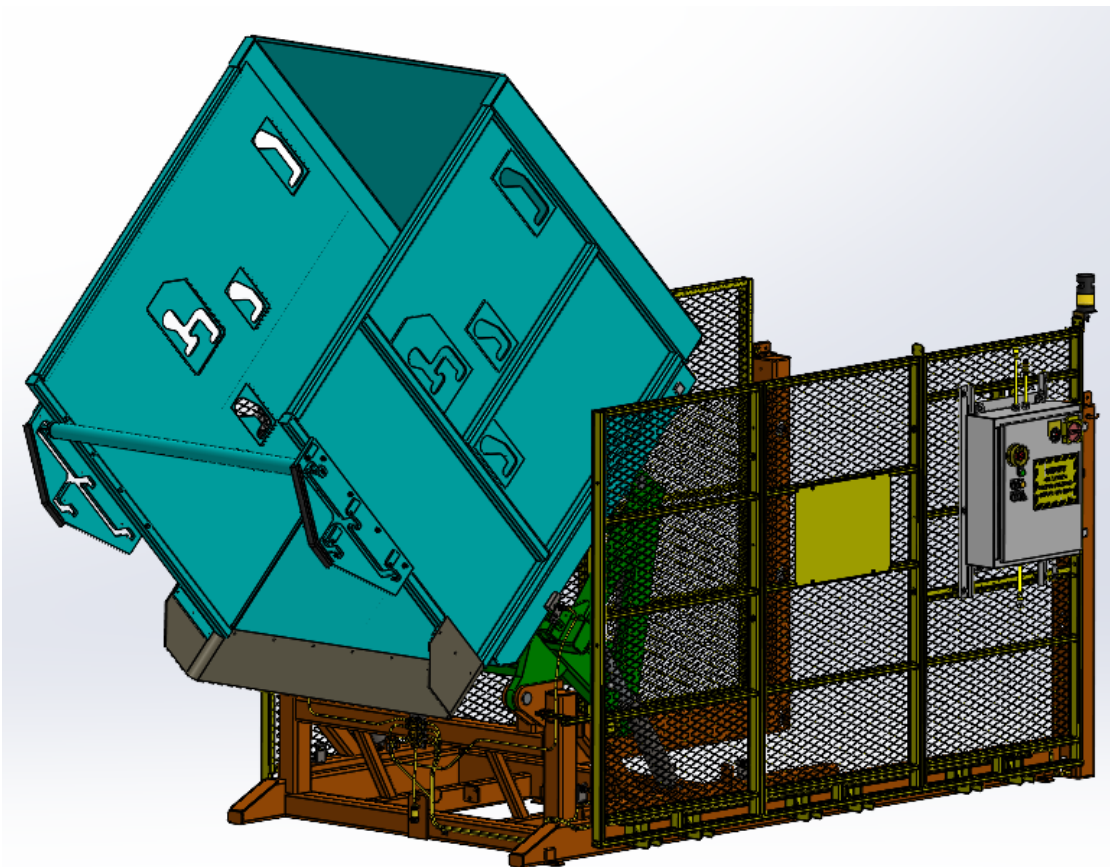

Model: _____

Serial Number: _____

Date placed in service: _____

SOUTHWORTH PRODUCTS CORP.
P.O. Box 1380, Portland, ME 04104-1380W
TF +1.800.743.1000 | D +1.207.878.0700 | F +1.207.797.4734
www.SouthworthProducts.com

Owner Manual

Contents

If viewing this manual electronically, just left click any section below to immediately view that area.

To get back to the table of contents, just click in area to the outside of the left border.

1	INTRODUCTION.....	5
1.1	Responsibilities of Owner and Users	6
1.2	Responsibilities of Operators	7
1.3	Positions for Loading and Unloading	9
2	SAFETY	10
2.1	Safety Alert Symbols.....	10
2.2	Signal Words.....	10
2.3	Safety Devices	11
2.4	Recommended Considerations For Lockout/Tagout Procedures (LOTO)	11
2.4.1	General.....	11
2.4.2	Best Practices	11
2.4.3	Additional Resources	11
3	LABELING	12
3.1	Label Placement Diagram.....	12
4	INSTALLATION	14
4.1	Pre-Installation Information	15
4.1.1	Floor Conditions & Leveling Information	15
4.1.2	Lagging & Shimming Information	16
4.2	Replacing Existing APCU.....	17
4.2.1	Replacing Existing First Generation APCU with Third Generation, Stand-Alone APCU	17
4.2.2	Replacement of Second Generation Lockheed-Martin APPS Integrated Machines	17
4.3	Installing a New Third Generation Stand-Alone APCU	17
4.3.1	Positioning the Machine	17
4.3.2	Hydraulic System Installation	18
4.3.3	Control Panel Mounting (Third Generation Stand-Alone APCU Only)	19
4.3.4	Electrical Connections (Third Generation Stand-Alone APCU Only)	21
4.4	Testing & Adjustments (Third Generation Stand-Alone APCU Only)	22

5	OPERATION OF THIRD GENERATION STAND-ALONE APCU	25
5.1	Loading	26
5.2	Controls.....	27
5.3	Operational Sequence (Third Generation Stand-Alone APCU Only).....	27
5.4	Manual Mode	29
5.5	Run Time Fault Sequence	29
6	MAINTENANCE & REPAIR	30
6.1	Torque Requirements for Hydraulic Hose Connections	32
6.2	Periodic Maintenance	32
6.2.1	Weekly Maintenance	32
6.2.2	Monthly Maintenance	33
6.2.3	Every Six Months or 500 Hours of Operation.....	33
6.3	Adjusting Proximity Sensors	34
6.3.1	Setting End of Travel for Tilt Down Function	34
6.3.2	Setting End of Travel for Tilt Up Function.....	34
6.3.3	Setting End of Travel for Dump Up Function.....	34
6.3.4	Setting End of Travel for Dump Down Function	35
6.4	Alternate Dump Down Hard Stop Positioning.....	36
6.5	Inspecting and Cleaning a Control Valve	37
6.6	Relieving Hydraulic Pressure	38
6.7	Hydraulic Cylinder Repair & Replacement.....	39
6.7.1	Removing Cylinders	39
6.7.2	Repacking Cylinder	40
6.7.3	Replacing a Cylinder	41
6.8	Ordering Replacement Parts	42
7	TROUBLESHOOTING.....	43

8	ELECTRICAL.....	46
8.1	Sensor Arrangement.....	47
8.2	Distinguishing Control Panels with PLC's Easy721-DC-TC vs Easy-E4-UC-12RC1.....	48
8.3	Wiring Schematic (Third Generation Stand-Alone APCU Only) - PLC (EASY721-DC-TC).....	49
8.4	PLC Logic (Third Generation Stand-Alone APCU Only) - PLC (EASY721-DC-TC).....	50
8.5	Wiring Schematic (Third Generation Stand-Alone APCU Only) - PLC (Easy-E4-UC-12RC1)...	52
8.6	PLC Logic (Third Generation Stand-Alone APCU Only) - PLC (Easy-E4-UC-12RC1).....	54
8.7	DC Power Supply Kit (Third Generation Stand-Alone APCU Only).....	56
9	HYDRAULICS.....	57
9.1	Hydraulic Schematic.....	57
9.2	Hydraulic Power Unit.....	58
10	OPTIONAL SUPPORT STANDS USE PROCEDURE.....	60
11	WARRANTY & CONTACT INFORMATION.....	62
12	APPENDIX.....	63
12.1	Installation of Generation Two, Lockheed Martin Integrated Replacement.....	63
12.1.1	Uninstalling the Existing Generation Two APPS Machine.....	63
12.1.2	Installing the Replacement Machine.....	64
12.1.3	Testing and Adjustments.....	66
12.1.4	Multi-Port Connections.....	67
12.1.5	Sensor Arrangement.....	68

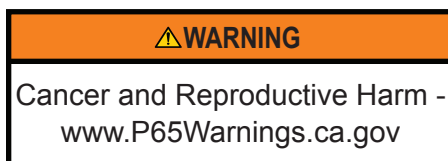

This label (part # 10095524) is required by California Law. For more information visit: www.P65Warnings.ca.gov

1 INTRODUCTION

The Southworth All-Purpose Container Unloader (APCU) is designed to unload containers and pallets. APCU units are designed for tilting and dumping of materials in a general indoor industrial setting.

This manual contains instructions on the safe and proper installation, use, and maintenance of the All-Purpose Container Unloader unit. Be sure that this manual is available to the people who install, use, or service the unit. Be sure that all personnel read this manual before they install, use, or service the unit.

The instructions in this manual are not necessarily all-inclusive, as Southworth cannot anticipate all conceivable or unique situations. In the interest of safety, please read this whole manual carefully. Please understand the material in this manual before you install, use, or service the APCU unit. If you have any questions about any of the instructions in this manual, please contact Southworth Products Corp.

Southworth's product warranty is shown on the rear cover of this manual. This instruction manual is not intended to be or to create any other warranty, express or implied, including any implied warranty of merchantability or fitness for a particular purpose, all of which are hereby expressly excluded. As set forth more specifically in the product warranty, Southworth's obligation under that warranty is limited to the repair or replacement of defective components, which shall be the buyer's sole remedy, and Southworth shall not be liable for any loss, injury, or damage to persons or property, nor for any direct, indirect, or consequential damage of any kind resulting from the APCU unit.

NOTICE

Installation, operation, and electrical information in this manual are applicable only to third generation, stand-alone APCU shipped approximately May 2015 and after, with control panels provided by Southworth.

Hydraulic information, maintenance, and troubleshooting (except for those items referring to the control panel, operator controls, or wiring) in this manual, is applicable to all third generation APCUs.

For installation information for second generation APPS system replacement APCU, see Appendix section. Control panels, operator controls, and electrical wiring for APPS system replacements use the original control panel, operator controls, and wiring provided by Lockheed-Martin. See the original documentation for operating instruction, control panel schematics, wiring information.

Contact Southworth Products for information about APCU machines shipped before May 2015 or machines with control panels, control and hydraulic schematics, PLC logic, or other differences that do not match those shown in this manual.

1.1 Responsibilities of Owner and Users

Basic Principles - Owners/users shall apply sound principles of safety, training, inspection, maintenance to the expected operating environment. It shall be the responsibility of the owner/user to advise the manufacturer where deflection may be critical to the application.

Manuals - Owners/users shall keep and maintain a copy of the operating and maintenance manual(s) and ensure its availability to operating and maintenance personnel.

Inspection and Maintenance - It shall be the responsibility of the users to inspect and maintain the machine as required to ensure proper operation. The frequency of inspection and maintenance shall be based upon the manufacturer's recommendations and be compatible with operating conditions and the severity of the operating environment. Machinery that is not in proper operating condition shall be immediately removed from service until repaired. Maintenance and repairs shall be made by a qualified person and the repairs shall be in conformance with the manufacturer's recommendations.

Maintenance Safety Precautions - Before adjustments and repairs are started on the machine, the following precautions shall be taken as applicable:

1. Remove the load from the load enclosure.
2. Lower load enclosure to the full down position.
3. Relieve system pressure from all circuits before loosening or removing any components.
4. All controls in the "off" position and all operating features secured from inadvertent motion by brakes, blocks, or other means.
5. Disconnect power and follow established owner/user lockout/tag out policies.
6. Follow precautions and directions as specified by the manufacturer.

Replacement Parts - When parts or components are replaced, they shall be replaced with parts or components approved by the original manufacturer.

Maintenance Training - The user shall ensure only qualified personnel inspect and maintain the machine in accordance with the manufacturer's recommendations.

Operator Training - An owner/user, who directs or authorizes an individual to operate the machine shall ensure that the individual has been:

1. Trained in accordance with the manufacturer's operating manual.
2. Made aware of the responsibilities of operators as outlined in the **Responsibilities of Operators** section of this manual.
3. Retrained, if necessary, based on the owners/user's observation and evaluation of the operator.

Modifications and additions shall not be performed without the manufacturer's prior written approval. Where such authorization is granted, capacity, operation, and maintenance instruction plates, tags, or decals shall be changed accordingly.

1.2 Responsibilities of Operators

Basic Principles - Operators shall apply sound principles of safety and good judgment in the application, and operation of the machine with consideration given to its intended use and expected operating environment. Since the operator is in direct control of the machine, conformance with good safety practices is the responsibility of the operator. The operator shall make decisions on the use and operation with due consideration for the fact that his or her own safety as well as the safety of other personnel on or near the machine is dependent on those decisions.

General Training - Only personnel who have received general instructions regarding the inspection, application, and operation of machine, including recognition and avoidance of hazards associated with their operation, shall operate the machine. Such topics covered shall include, but not necessarily be limited to, the following issues and requirements:

1. A pre-start inspection
2. Responsibilities associated with problems or malfunctions affecting the operation of the machine
3. Factors affecting stability
4. The purpose of placards and decals
5. Workplace inspection
6. Safety rules and regulations
7. Authorization to operate
8. Operator warnings and instructions
9. Actual operation of the machine. Under the direction of a qualified person, the trainee shall operate the machine for a sufficient period of time to demonstrate proficiency in actual operation of the machine.

Pre-start Inspection - Before use each day or at the beginning of each shift, the machine shall be given a visual inspection and functional test including but not limited to the following:

1. Operating and emergency controls
2. Safety devices
3. Hydraulic system leaks
4. Electrical cables and wiring harness
5. Loose or missing parts
6. Nameplates, precautionary and instructional markings and/or labeling
7. Guarding system
8. Items specified by the manufacturer

Problem or Malfunctions - Any problems or malfunctions that affect the safety of operations shall be repaired prior to the use of the machine.

Before Operations - The operator shall:

1. Read and understand the manufacturer's operating instruction(s) and user's safety rules or have them explained.
2. Understand all labels, warnings, and instructions displayed on the machine or have them explained.

Workplace Inspections - Before the machine is used and during use, the operator shall check the area in which the machine is to be used for possible hazards such as, but not limited to:

1. Bumps, floor obstructions, and uneven surfaces
2. Overhead obstructions and electrical hazards
3. Presence of unauthorized persons
4. Other possible unsafe conditions as noted in the operating manual.

Operator Warnings and Instructions - The operator shall ensure the operation of the machine is in compliance with the following:

1. **Guarding system** - Guarding shall be installed and positioned, and access gates or openings shall be secured per the manufacturer's instructions (If applicable).
2. **Distribution of load** - The load and its distribution on the load enclosure shall be in accordance with the manufacturer's rated capacity for that specific configuration.
3. **Maintaining overhead clearance** - The operator shall ensure that adequate clearance is maintained from overhead obstructions and energized electrical conductors and parts.
4. **Point of Operation** - The operator shall not place any part of their body under the load enclosure.
5. **Precaution for moving equipment** - When other moving equipment or vehicles are present, special precautions shall be taken to comply with the safety standards established for the workplace.
6. **Reporting problems or malfunctions** - The operator shall immediately report to a supervisor any problem(s) or malfunction(s) that become evident during operation. The operator shall ensure all problems and malfunctions that affect the safety of operations are repaired prior to continued use.
7. **Capacity limitation** - Rated capacity shall not be exceeded when loads are transferred to the load enclosure.
8. **Work area** - The operator shall ensure the area surrounding the machine is clear of personnel and equipment before lowering the load enclosure.
9. **Securing the machine** - The operator shall comply with the means and procedures provided to protect against use by an unauthorized person(s).
10. **Altering safety devices** - Safety devices shall not be altered or disabled.
11. **Modifications** or alterations of the machine or the fabrication and attaching of frameworks or the mounting of attachments to the machine or the guarding system shall only be accomplished with prior written permission of the manufacturer.
12. **Assistance to the operator** - If an operator encounters any suspected malfunction or any hazard or potentially unsafe condition relating to capacity, intended use, or safe operation, the operator shall cease operation of the machine and request further instruction from the owner/user.
13. **Problems or malfunctions** - Any problem(s) or malfunction(s) that affect the safety of operations shall be repaired prior to the use of the machine.

1.3 Positions for Loading and Unloading

Containers are to be loaded onto the APCU at the lowered position only as shown below.

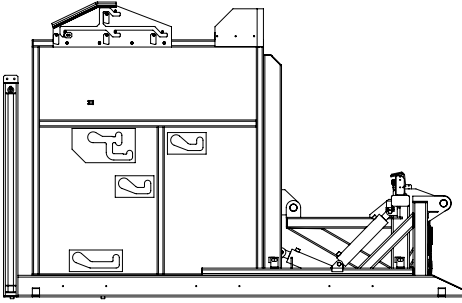

Loading Position Only - do not load approved containers into APCU at any other position

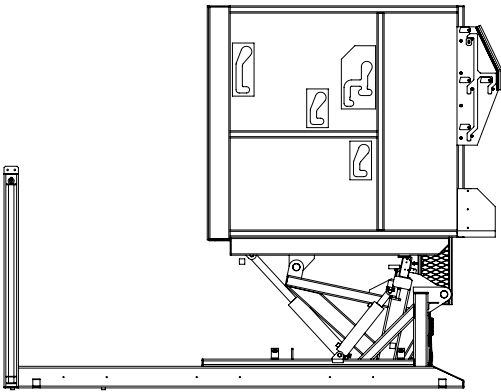

Tilted Position - before advancing to Dump Position

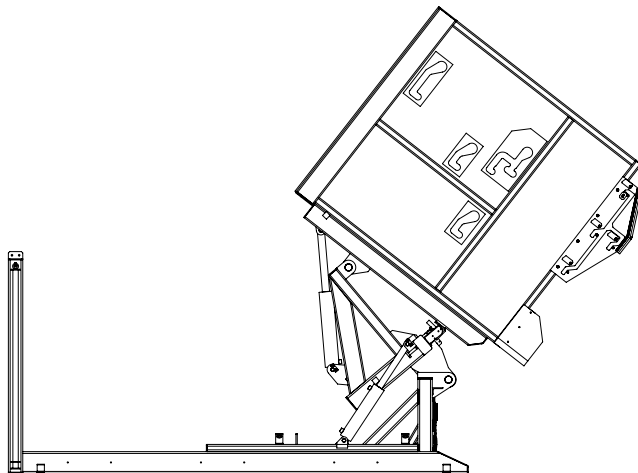

Dump Position - Approved container is unloaded onto conveyor

2 SAFETY

All personnel installing, operating, and maintaining this machine shall read and understand this manual. For questions or concerns contact the manufacturer.

This machine shall be installed, operated, and maintained by trained and/or qualified personnel only.

2.1 Safety Alert Symbols



A symbol that indicates a hazard. It is composed of an equilateral triangle surrounding an exclamation mark. The safety alert symbol is only used on hazard alerting signs. It is not used on safety notice and safety instructions signs.

A – For use with **DANGER** signal word; (safety white triangle, safety red exclamation mark, safety red background)

B – For use with **WARNING** signal word; (safety black triangle, safety orange exclamation mark)

C – For use with **CAUTION** signal word; (safety black triangle, safety yellow exclamation mark)

D – For use with **DANGER, WARNING, or CAUTION** signal words; (**D** is a safety yellow triangle with a safety black border and safety black exclamation mark);

2.2 Signal Words

DANGER



DANGER Indicates a hazardous situation that, if not avoided, will result in death or serious injury.

WARNING



WARNING Indicates a hazardous situation that, if not avoided, could result in death or serious injury.

CAUTION



CAUTION Indicates a hazardous situation that, if not avoided, could result in minor or moderate injury.

NOTICE



NOTICE Indicates information considered important, but not hazard-related (e.g., messages relating to property damage).

2.3 Safety Devices

This machine is equipped with devices and features to protect the operator and nearby personnel from severe injury or death. These features and devices shall be installed and functioning correctly during operation.

Side Guarding – Protects operators and nearby personnel from moving components during operation. These must be installed before operation of the machine.

Photo Eyes – Photo eyes located on the front, loading side, of the load enclosure prevent the machine from operating if the light beams are broken. These photo eyes must be installed and operating correctly before operation.

2.4 Recommended Considerations For Lockout/Tagout Procedures (LOTO)

2.4.1 General

While following local codes and procedures for safely operating, maintaining, and repairing industrial equipment, it is necessary for authorized personnel to also review owner manuals for more detailed instruction on how to avoid potential hazards. With regard to your Southworth equipment, consider the following information as you operate, maintain and make repairs.

1. Prepare and train for controlling any electrical, hydraulic, gravitational or structural (e.g. compressed spring) hazardous energy source of the machine and the perimeter around the machine.
2. Review and follow your company's and/or local governing authority's lockout/tagout procedures before continuing.
3. Maintain your company's and/or local governing authority's lockout/tagout status until all repairs can be completed as desired.

It is important that before returning your equipment to operating status, all personnel in the affected area are made aware and are allowed ample time to react to the repaired machine being brought back online.

2.4.2 Best Practices

1. Keep your plan simple and user focused. If it's understood, it will be more easily followed.
2. Be consistent in labeling and in procedures described.
3. Expect accountability with safety training and enforcement of all requirements.
4. Verify that all energy sources have been controlled.

2.4.3 Additional Resources

Scan below for some other useful information regarding establishing LOTO procedures.



3 LABELING

This machine has labeling to indicate potential hazards this machine may pose when operating and/or maintaining the machine. All labels must be legible. If any label is missing, damaged, or otherwise illegible contact the manufacturer for replacement labels.

3.1 Label Placement Diagram

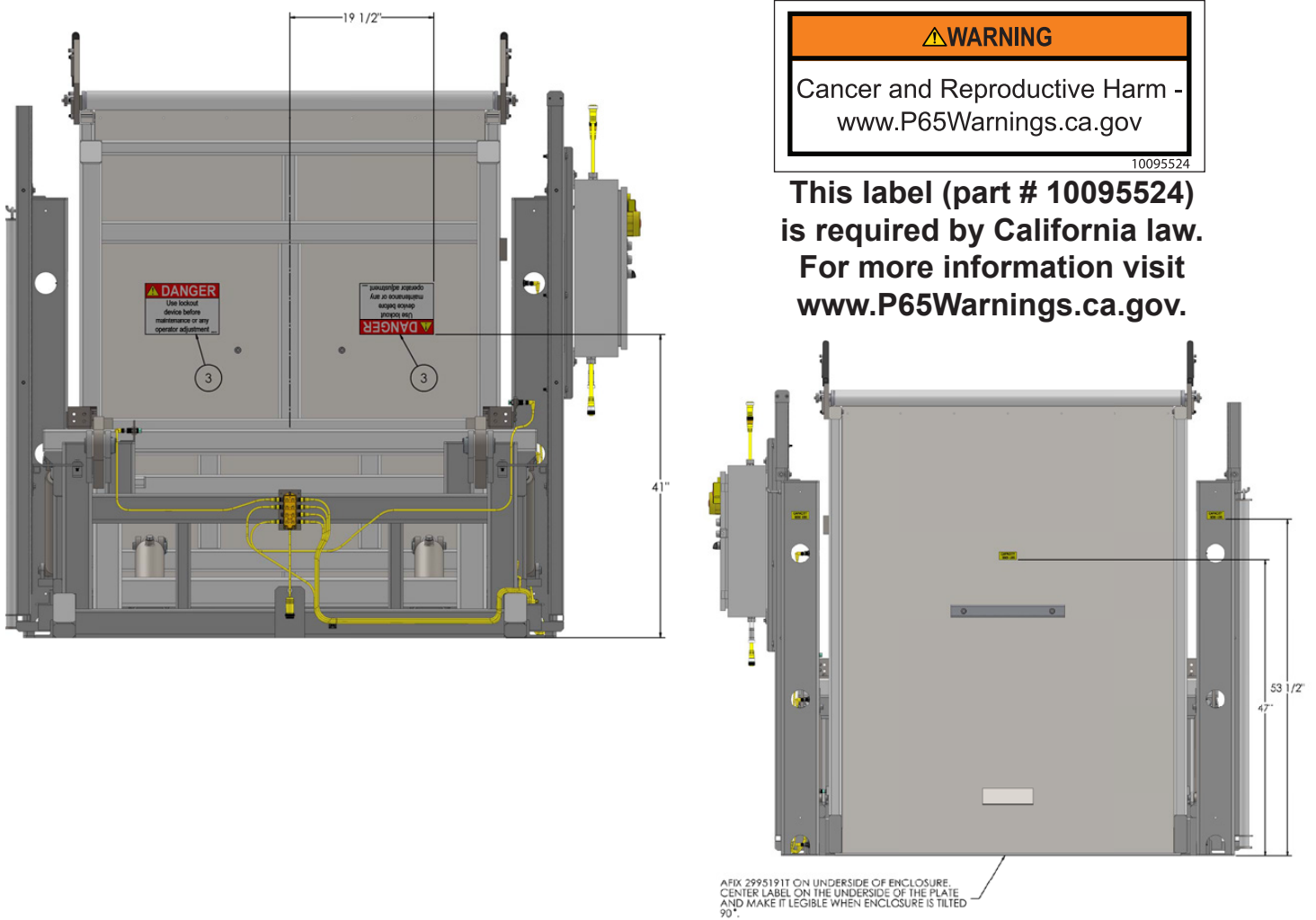

Item No.	QTY.	Description	Part No.
1	2	DECAL, ALL-PURPOSE CONTAINER UNLOADER	2995289T
2	1	TAG, APCU SERIAL NUMBER/LOT	2996827T
3	3	DECAL, DANGER LOCKOUT FOR MAINTENANCE	2995191T
4	3	DECAL, CAPACITY, 3000 LB	5908708T
5	2	DECAL, POSITION SUPPORT	2998592T
6	REF	LABEL LOCATION DIAGRAM, SUPPORT STAND	3053184T
7	1	LD DCL 10.00X8.00 VERIFY CONTAINER IS PR	10077573
8	1	LD DCL 8.50X11.00 APCU OPERATOR INSTRUCT	10090803
9	1	LD DCL 8.50X11.00 APCU OPERATOR INSTRUCT	10090804

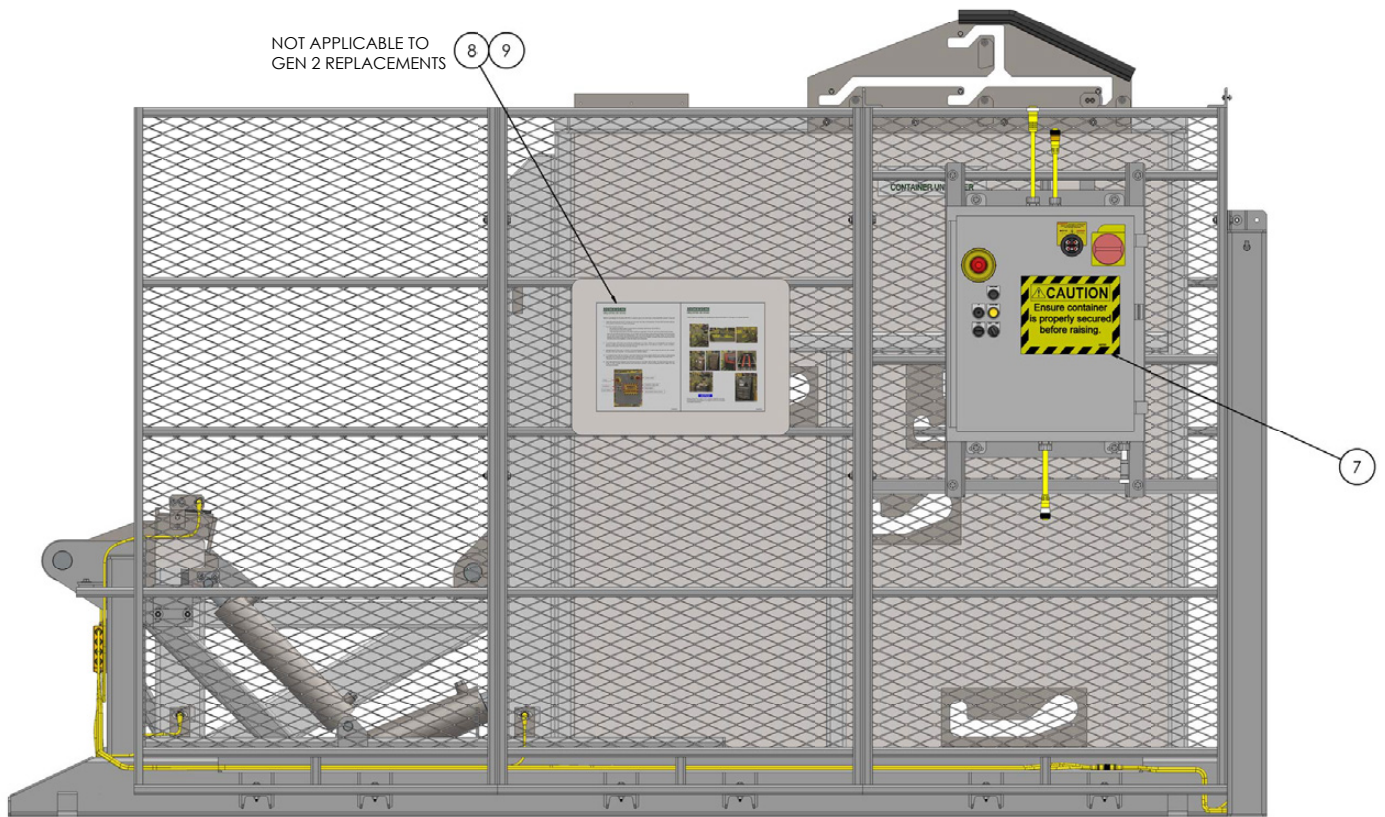
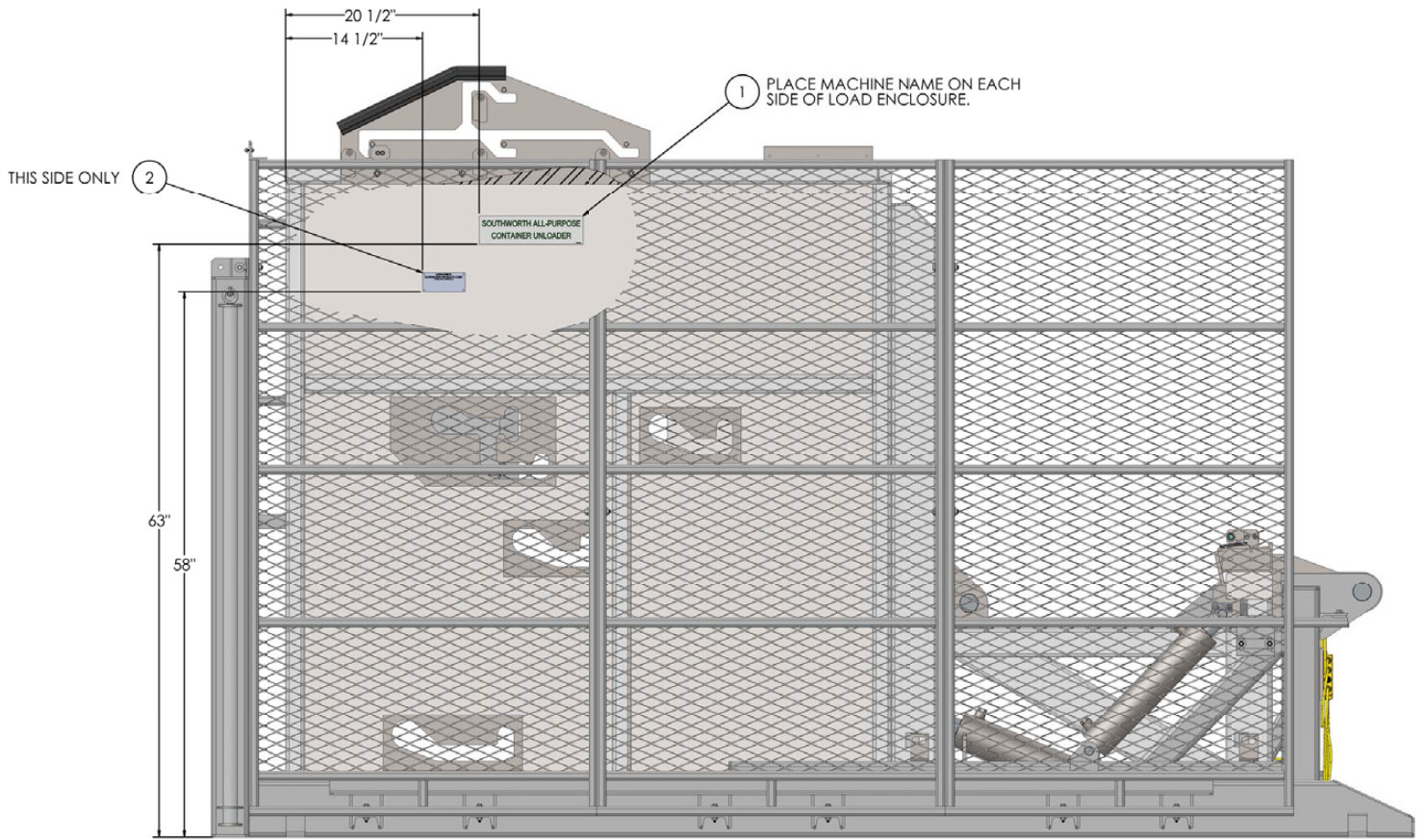

4 INSTALLATION

DANGER

High Voltage: Electrical service and installation must be performed by trained and/or qualified personnel. Lock-out/ tag-out the power source before installation.

Pressurized fluids can penetrate skin and cause severe injury or death. Always use proper personal protective equipment when installing pressurized systems. Relieve hydraulic system pressure before performing any adjustments/maintenance or repair on the hydraulic system. Treat all lines as if pressurized and open any necessary fitting slowly and do not completely disconnect until all pressure has been relieved. See Relieving Hydraulic Pressure and Torque Requirements for Hydraulic Hose Connections sections.

Electric motors create sparks. Do not install the power unit in an area where flammable gases may be present.

All electrical components and the hydraulic power unit must be protected from wet and/or dirty environments unless specifically configured for such environments.

Pinch points, shear points and crush hazards exist when moving and transporting the machine. Do not enter under any equipment while moving or during transport. Keep hands, feet, and loose clothing away from moving equipment.

Do not enter into the load area when load enclosure is raised.

Do not enter beneath the raised load enclosure.

Do not sit, stand, or ride in the load enclosure.

This machine must be installed on a solid, stable, level surface as described in this manual.

The installer is responsible for ensuring this machine will properly interface with the chute/conveyor without interference.

Upon receipt of the machine, remove shipping materials and verify all equipment and components on the packing slip were received. Inspect the machine, power unit, and other equipment for any damage that may have occurred during shipping. If damage is found contact the manufacturer before continuing the installation.

4.1 Pre-Installation Information

In addition to typical tools for installation of industrial equipment, installers will need the following to complete the installation:

- Electric fork truck with a minimum capacity of 5000 lb. and six-foot-long fork extensions.
- Rotary hammer drill with 5/8" bit for drilling concrete.

4.1.1 Floor Conditions & Leveling Information

Southworth recommends the following floor conditions:

1. Flooring must be eight-inch reinforced concrete with no cracking.
2. Lags must not be located on cracks or seams in the concrete. See **Lagging & Shimming Information** section.
3. Side to Side angular slope of less than ½ degree. This would equate to one side higher by no more than 3/8".
 - Shimming up low side to be less than ¼" difference is acceptable.
 - Keep as much base frame in contact with the floor as possible.
4. Front to back floor slope for the unloader is not as critical, other than making sure rolling containers stay in place when placed in the dumping enclosure.
 - Install so base frame contacts floor as much as possible.
5. If high points occur in the area of floor where the machine is to be installed, they must not create side to side frame deviation greater than indicated in item 3.
6. High points in the area under the load enclosure must not create a need for more than 1/4" of shimming.

4.1.2 Lagging & Shimming Information

The APCU has six lag points, use of all six lag points are required to provide proper support of the APCU. There must be no gap between the lag plate and floor. If a gap exists shims are required to properly support the machine.

Lag bolts are supplied with the machine and must be installed according to the bolt manufacturer's specifications. **See Lag Bolt Usage Specifications below.**

Never reuse existing lag holes.

A set of shims are provided with the machine. Shims must completely fill the gap between the floor and lag plate and must fit tightly without causing deflection of the lag plate. The lag bolts are not to be used to deflect the frame in order to compress the lag angle onto the shim.

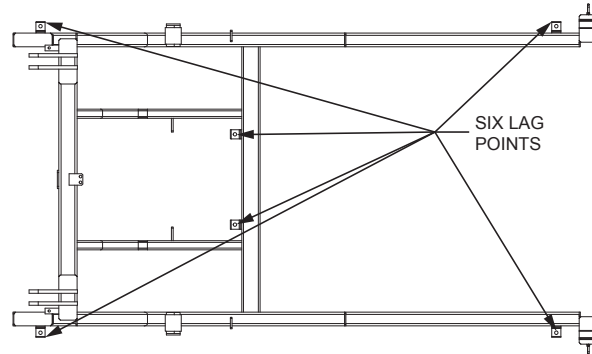

Fully Threaded Advantage

Trubolt's fully threaded feature eliminates subsurface obstruction problems.

Fully threaded design accommodates various material thicknesses at the same embedment. One anchor length saves time and money.

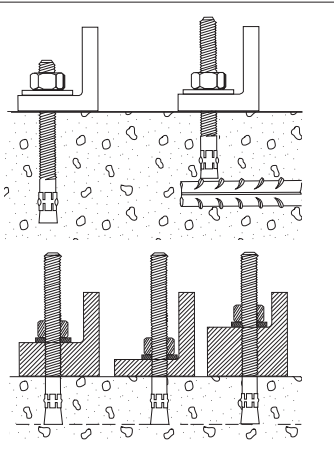

Red Head Trubolt WS-5850 Wedge Anchor (Southworth part no. 2996870T)

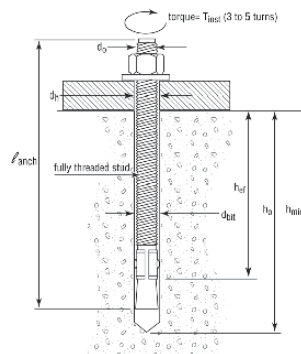

Installation Information			
	Symbol	Units	Nominal Anchor Diameter (in.)
			5/8
Anchor outer diameter	d_0	In	0.625
Nominal carbide bit diameter	d_{bit}	In	5/8
Effective embedment depth	h_{ef}	In	2-1/2
Min hole depth	h_0	In	3-3/4
Min slab thickness	h_{min}	In	5
Installation Torque	T_{inst}	Ft-lb	90

INSTALLATION STEPS

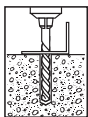

1. Select a carbide drill bit with a diameter equal to the anchor diameter. Drill hole to any depth exceeding the desired embedment. See chart for minimum recommended embedment.

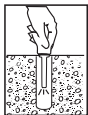

2. Clean hole or continue drilling additional depth to accommodate drill fines.



3. Assemble washer and nut, leaving nut flush with end of anchor to protect threads. Drive anchor through material to be fastened until washer is flush to surface of material.



4. Expand anchor by tightening nut 3-5 turns past the hand tight position, or to the specified torque requirement.

Recommended Edge and Spacing Distance Requirements

Anchor Diameter In. (mm)	Embedment Depth In. (mm)	Edge Distance Required to Obtain Max Working Load In. (mm)	Min. Allowable Edge Distance at Which the load Factor Applied = .65 In. (mm)
5/8 (15.9)	2-3/4 (69.9)	4-13/16 (122.2)	2-7/16 (61.9)

4.2 Replacing Existing APCU

4.2.1 Replacing Existing First Generation APCU with Third Generation, Stand-Alone APCU

If replacing an existing first generation machine:

1. Lower the load enclosure to the fully lowered position.
2. Lock-out/tag-out power to the machine.
3. Relieve all pressure in the hydraulic system. See **Relieving Hydraulic Pressure** section.
4. Disconnect all wiring to the machine.
5. Disconnect hydraulic hoses. Use a bucket to catch fluid that may leak.
6. Unfasten the nuts on the lags.
7. Using a fork truck lift the machine off of the lags and carefully remove the machine.

NOTICE

⋮
⋮ **Check with site contact about components that need to be saved.**
⋮

8. Cut off existing lag bolts flush with floor.
9. Follow the Instructions for **Installing a New Third Generation Stand-Alone APCU**.

4.2.2 Replacement of Second Generation Lockheed-Martin APPS Integrated Machines

For installation of second generation APCU that were integrated by Lockheed Martin, see Appendix **Installation of Generation Two, Lockheed Martin Integrated Replacement** section.

4.3 Installing a New Third Generation Stand-Alone APCU

4.3.1 Positioning the Machine

1. Remove the fasteners holding the machine to the shipping skid.
2. Carefully lift the machine from the shipping pallet using a fork truck. The base frame must be supported during lifting and transport.
3. Move the machine to the desired location.
4. Remove the red shipping brackets, located across front posts and the rear of the load enclosure.
5. Level the base frame, following the requirements in the **Floor Conditions & Leveling Information** section.
6. If necessary, use shims under the lag plates. Follow the requirements in the **Lagging & Shimming Information** section.
7. After verifying that the machine is level, lag the machine to the floor. Follow the guidelines in the **Lagging & Shimming Information** section. Any resulting gaps between the base frame and floor should be shimmed and/or grouted to ensure the frame is fully supported.

4.3.2 Hydraulic System Installation

1. Locate the Hydraulic Power Unit (HPU) in the desired location.
2. Make hydraulic connections according to the hydraulic schematic. Connect each port A through D to the corresponding connection point on the machine. See **Torque Requirements for Hydraulic Hose Connections** section when making or tightening any hydraulic hose connections. If connection points and/or hoses are not marked by the manufacturer. See **Hydraulics** section for hydraulic schematic.

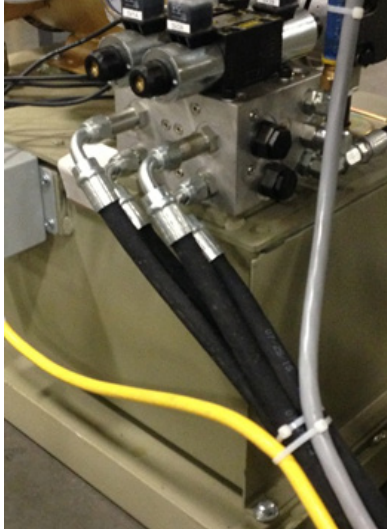

⚠ CAUTION

See **Torque Requirements for Hydraulic Hose Connections** section when making or tightening any hydraulic hose connections.

Incorrect hydraulic connections may cause damage to the machine. Verify connections before attempting to operate the HPU.

Ensure all hoses are neat and routed to prevent damage or interference with personnel and other components during operation.

4.3.3 Control Panel Mounting (Third Generation Stand-Alone APCU Only)

Unless otherwise specified, the control panel mounting bracket is installed on the left-hand side of the machine, as seen from the load enclosure opening. The control panel may be mounted on the right-hand side by following these steps:

1. Unfasten the guard panel with the control panel mounting bracket. Leave the mounting bracket attached to the panel.
2. Unfasten the panel with the operator's instructions mounting plate.
3. Unfasten the first two guard panels on the right-hand side of the machine.

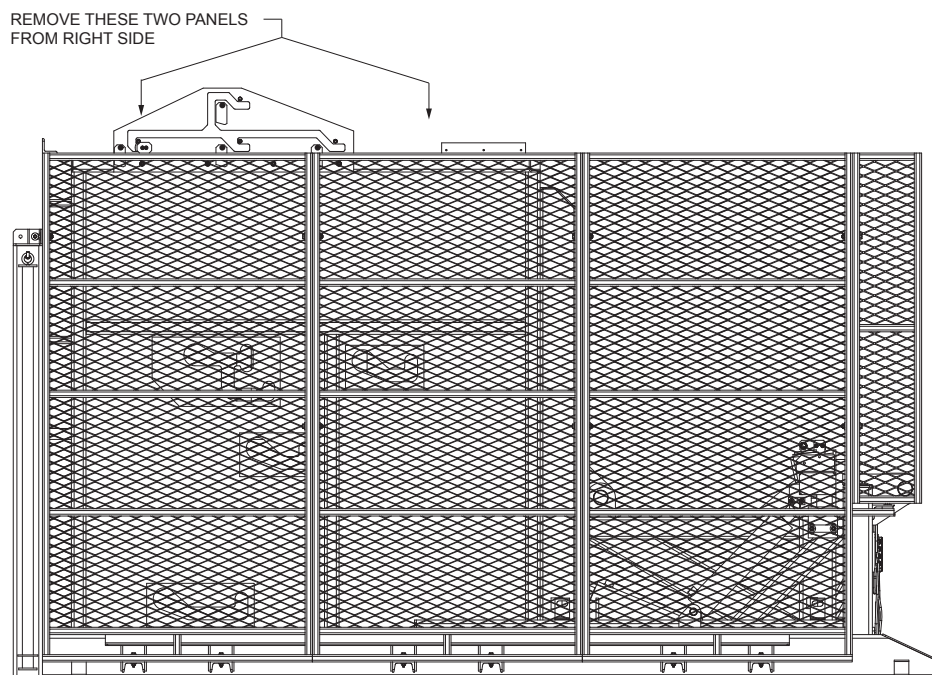
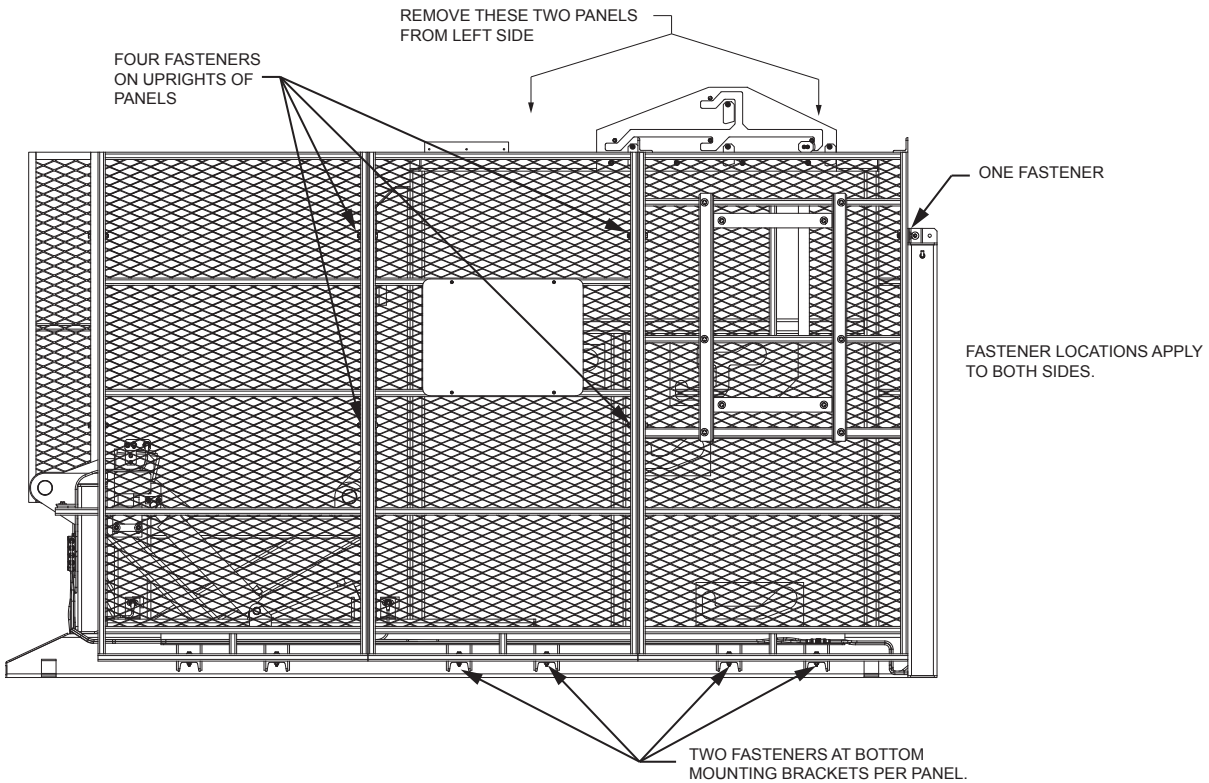

4. Remount the guard panel with the operator's instructions mounting plate on the right side of the machine, in the middle position.
5. Remount the guard panel with the control panel mounting bracket on the right side of the machine in the position closest to the load enclosure opening.
6. Remount the two other panels on the left side of the machine.

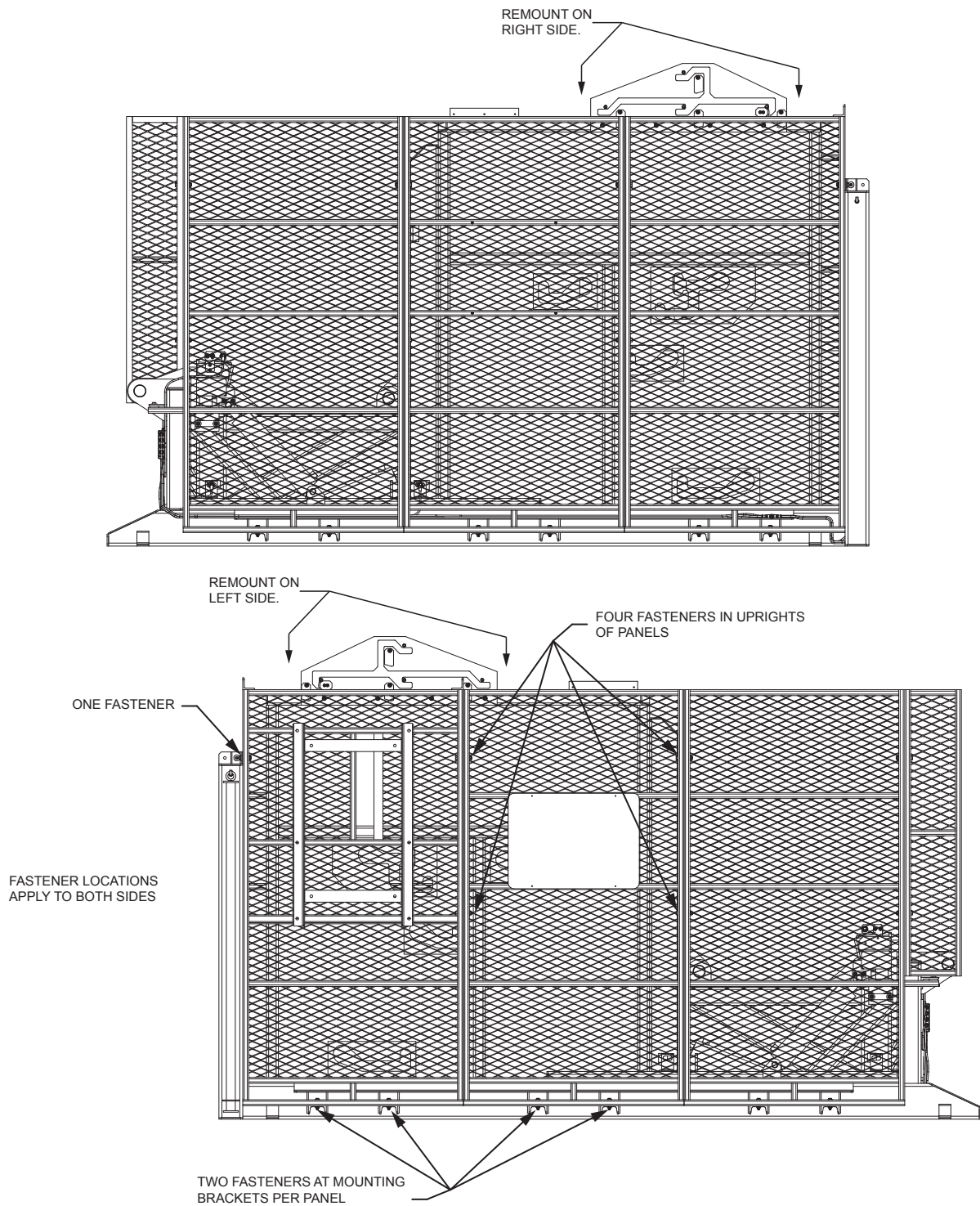

4.3.4 Electrical Connections (Third Generation Stand-Alone APCU Only)

1. Install the control panel using the supplied hardware.
2. Install the warning light/alarm using the supplied hardware.
3. Connect the four quick disconnect connectors according to the diagram.
4. Connect the push-button controls into the control panel according to the wiring schematic. See **Electrical** section.
5. Connect the main power and ground to the main disconnect switch in the control panel. See **Electrical** section.
6. Verify all electrical and hydraulic connections have been made correctly and properly tightened. Also, inspect all connections within the control panel.
7. Install the conveyor lip kit. Center the flap on the conveyor and drill holes in flap and conveyor. Secure the flap to the conveyor using the supplied hardware.
8. Clean work area. Ensure all hoses and wiring are neat and routed to prevent damage or interference with personnel other components during operation.

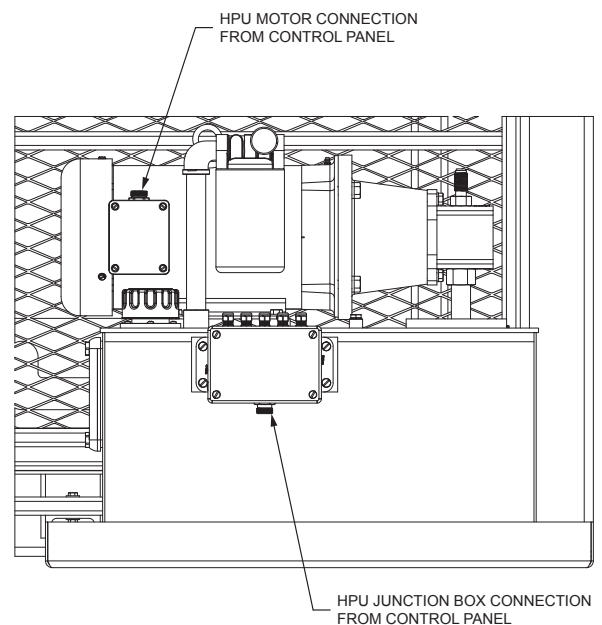
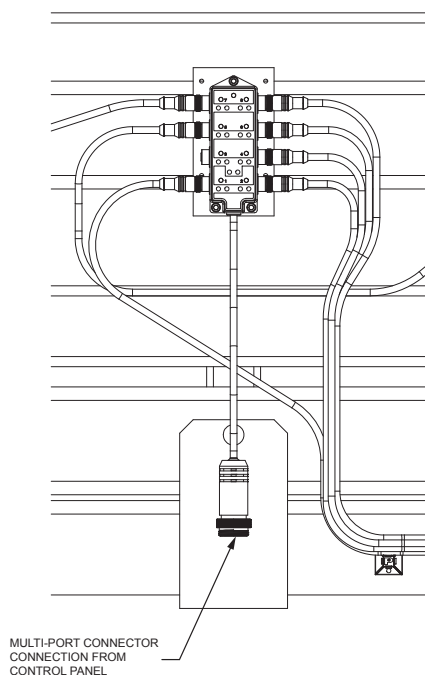
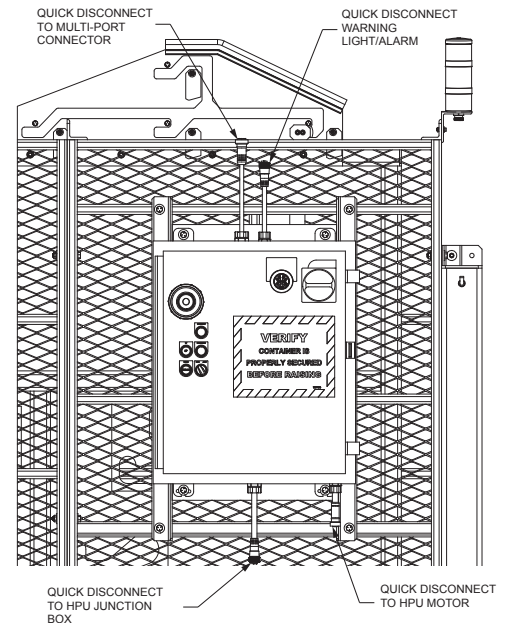
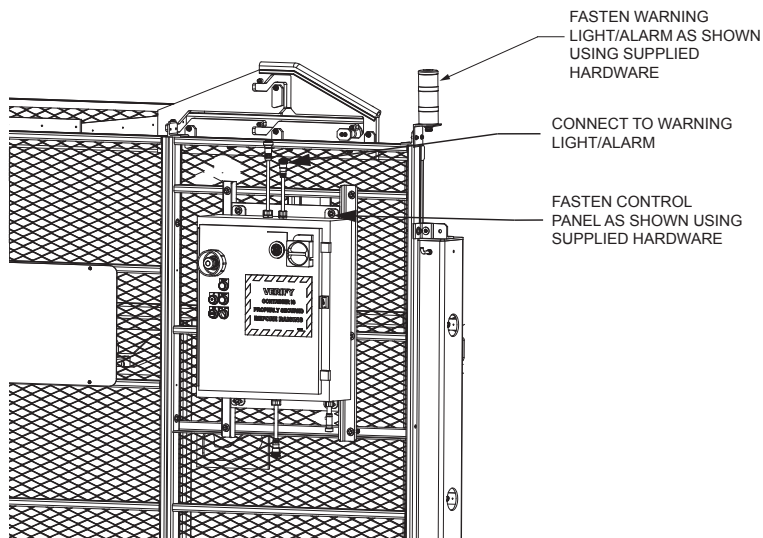

DANGER

Pinch points, shear points and crush hazards exist when operating the machine. Do not enter under any equipment while testing or operating the machine. Keep hands, feet, and loose clothing away from moving equipment.

Do not enter into the load area when load enclosure is raised.

Do not enter beneath the raised load enclosure.

If any motion takes longer than twenty seconds a Runtime Fault will occur, the machine will stop, and the **GUARD RESET** light will flash. Trained and/or Qualified personnel must determine and repair the cause of the fault before continuing operation. See Troubleshooting Section.

Ensure all guarding is installed before operating the machine.

In Emergency situations the machine may be stopped by pressing the red Emergency Stop button.

To stop the machine, in non-emergency situations, before the proximity switches are reached turn the **MANUAL/AUTO** selector switch to **MANUAL**.

1. Ensure the area in and around the machine is clear of debris, tools, and personnel.
2. Turn on the main disconnect switch on the control panel to the on position. The red emergency stop push-button light will turn on.
3. Verify Grace Voltage indicator, located on the cover of the control panel is functioning. The LEDs for L1, L2, and L3 should be illuminated. If the ground LEDs are illuminated, there is a ground fault condition that must be corrected before continuing.
4. Confirm the correct voltage is coming into the panel. See **Electrical** section.
5. Pull the E-STOP switch out.
6. Press the E-STOP RESET push-button. The red E-STOP light should turn off and the green E-STOP RESET and amber GUARD RESET push-button light will turn on.
7. Turn the MANUAL/AUTO selector switch to the AUTO position.
8. Press the GUARD RESET button. The GUARD RESET light should turn off.
9. Verify all three photo eyes across the load enclosure opening are functioning correctly by placing an object in front of the bottom photo eye to obstruct the beam. When the beam is obstructed, the GUARD RESET light should turn on and the machine should not be operable. Remove the object obstructing the beam and press the GUARD RESET button. Repeat for the middle and upper photo eyes.

10. Press the GUARD RESET button, the GUARD RESET light should turn off. Press and hold the UP button for one second. The warning alarm should begin and the light should flash. Release the button, the warning alarm and light should continue. After one second the load enclosure will begin to tilt to the tilt up (PRS1) proximity switch and stop. The load enclosure should move smoothly and come to rest of the rubber stop pads without crashing into them. If the load enclosure does crash into the pads or does not reach the pads before stopping, the tilt up (PRS1) proximity switch must be adjusted. Make adjustments and repeat until correct position is achieved. See **Adjusting Proximity Switches** section.

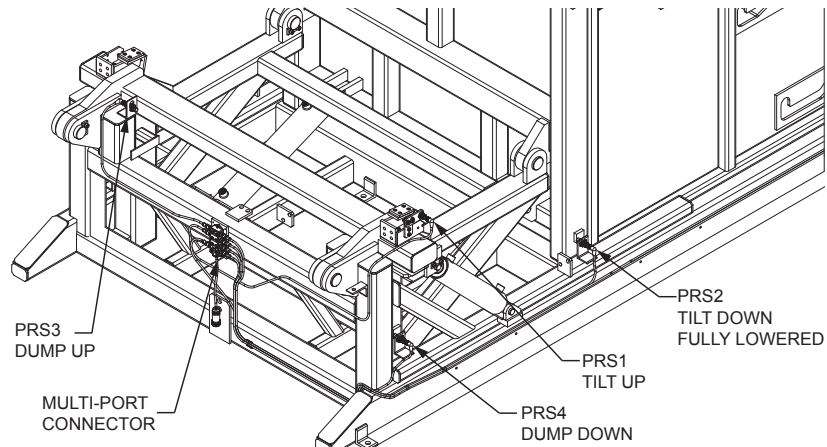

11. With the tilt up (PRS1) proximity switch properly adjusted, tilt the load enclosure to the Tilt up (PRS1) position. After the load enclosure stops, press and hold the UP button. The warning alarm and light should begin and after three seconds the load enclosure will begin to dump. If the UP button is released during this travel the load enclosure should stop. To resume travel the UP button must be pressed and held until desired position is achieved. The final dump position can be altered as needed by adjusting the Dump up (PRS3) proximity switch. See **Adjusting Proximity Switches** section.

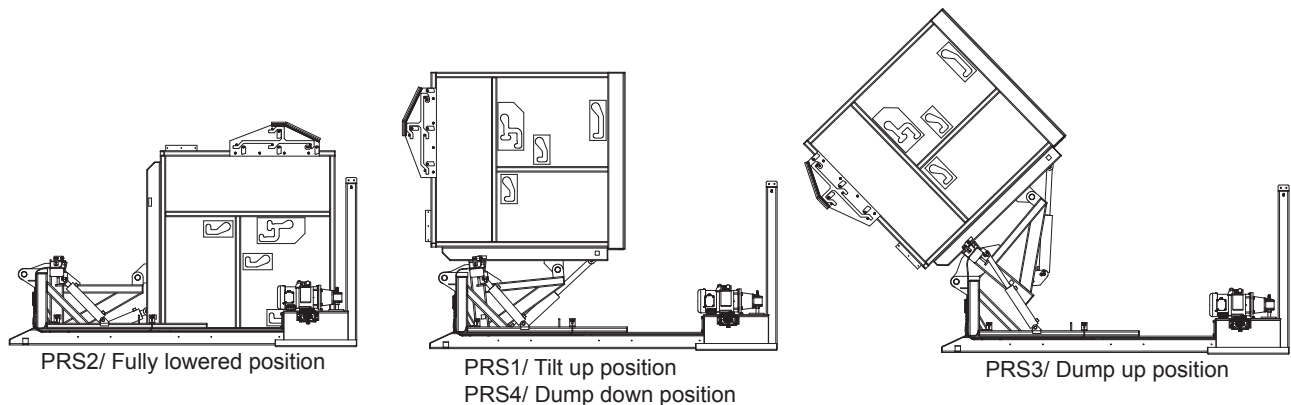

12. With the Dump up (PRS3) proximity switch adjusted as desired and the load enclosure at Dump up (PRS3) position, press and hold the DOWN button. The warning alarm and light will begin and after three seconds the load enclosure will begin to move. Release the DOWN button. The warning alarm and light should continue. The load enclosure will lower to the Dump down (PRS4) position, stop, wait for one-half second and begin to lower to the Tilt down (PRS2), or fully lowered position.

- When lowering to the Dump down (PRS4) position the rubber stop pads, located on the rear of the tilt frame, must come to rest on the cross member without powering into it. If the tilt frame stops before coming to rest on the cross member or the motor continues to run after the pads come in contact with the cross member immediately stop the machine and adjust the Dump down (PRS4) proximity switch. See **Adjusting Proximity Switches** section.
- When lowering to the Tilt down (PRS2) position the front lip of the load enclosure must rest on the floor without powering into the floor. The motor should turn off just as front lip of the load enclosure begins to contact the floor. See **Adjusting Proximity Switches** section.

NOTICE

• **If the motor continues to run after the load enclosure contacts the floor immediately stop the motor. Do not allow the load enclosure to power into the floor or the machine may be damaged.**

• **If any part of the load enclosure contacts the floor before the front lip, immediately stop the machine or the machine may be damaged. Further leveling and shimming may be required. See Floor Conditions & Leveling Information & Lagging & Shimming Information sections.**

5 OPERATION OF THIRD GENERATION STAND-ALONE APCU

DANGER

Only trained and/ or qualified personnel shall operate this machine. Personnel operating this machine must read and understand this manual.

In the event of a malfunction, engage the E-STOP. Do not return to service until the cause of the malfunction has been determined and remedied. Lock-out/tag-out the power source before performing maintenance or repair.

Pinch points, shear points and crush hazards exist when operating the machine. Do not enter under any equipment while testing or operating the machine. Keep hands, feet, and loose clothing away from moving equipment.

Do not enter into the load area when load enclosure is raised.

Do not enter beneath the raised load enclosure.

Do not sit, stand, or ride in load enclosure during operation.

Verify the area around the machine is clear of debris and/ or personnel before operating.

All guarding must be in place before operation.

This machine must be operated only indoors on substantially firm, smooth, even, and prepared surfaces.

Always keep power and control cords clear of foot and vehicle traffic during operation.

During operation, operator must be in view of the machine at all times.

All loads must be secured, using the retaining bar before raising.

Do not load or unload the machine while moving.

Loads shall not exceed the rated capacity. Only pre-specified containers are to be used.

5.1 Loading

This machine is capable of retaining only the following containers: ERMIC, BMC OTR, universal, pallets, and wire containers. Each container type has a specific retainer bar location. Locations are labeled, by USPS, on the load enclosure. Loads must always be secured with the retainer bars in the correct location.

NOTICE

When using BMC or OTR that are overloaded, you will have to level them out before putting it into the unloaders. Do not put the top bar into the Postal Pak Position.

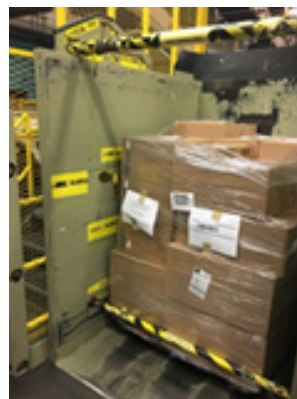
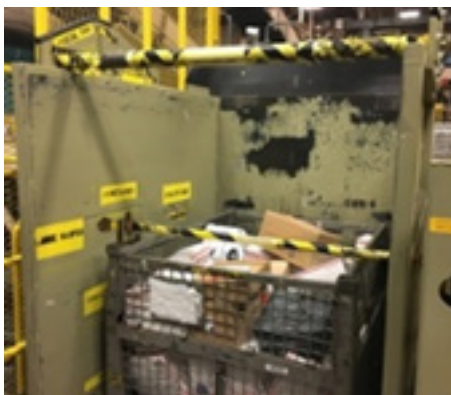
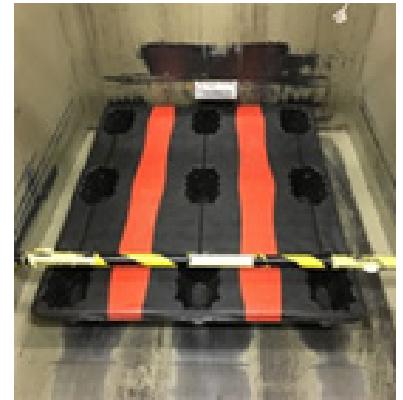

5.2 Controls

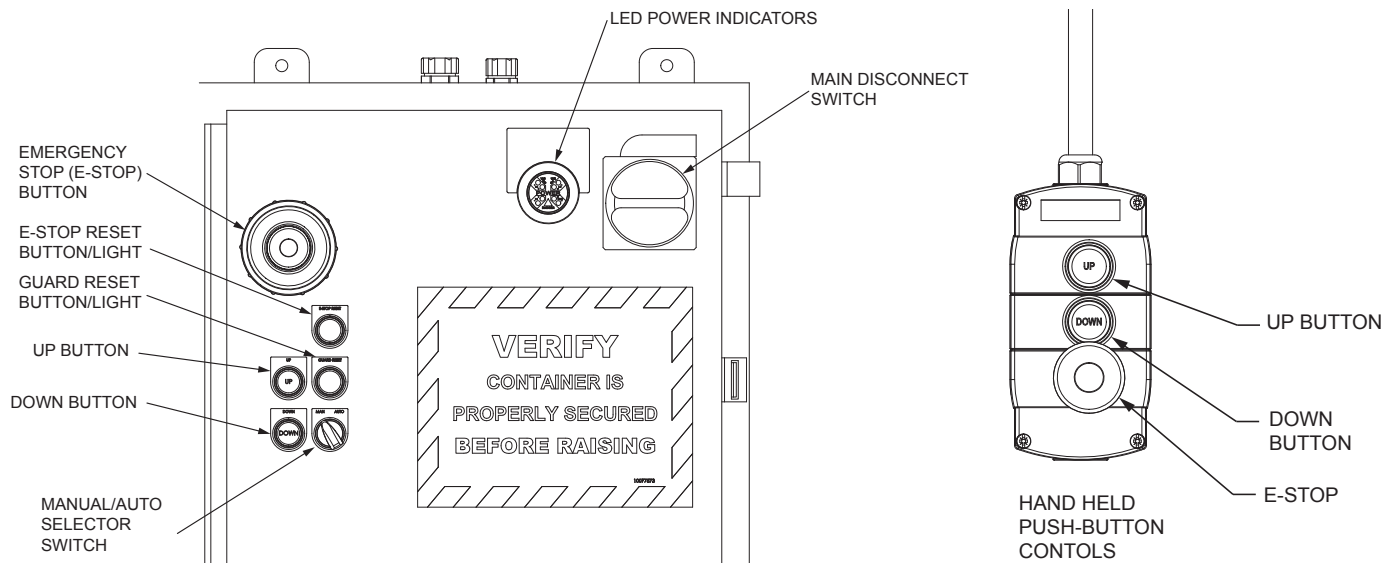

5.3 Operational Sequence (Third Generation Stand-Alone APCU Only)

NOTICE

If any of the three photo eyes are obstructed at any time, all motion will stop and the GUARD RESET pushbutton light will turn on. No motion can occur until the operator has cleared the obstruction and pressed the GUARD RESET pushbutton.

If the E-STOP or E-STOP button on the hand-held controls is pressed, the operator must perform steps two and three to resume operation.

In Emergency situations the machine may be stopped by pressing the red Emergency Stop button.

To stop the machine, in non-emergency situations, before the proximity switches are reached turn the MANUAL/AUTO selector switch to MANUAL.

1. Operator turns rotary disconnect switch to ON. The red E-STOP light will turn on.
2. Operator pulls or releases E-STOP pushbutton in the door of the control panel or the "STOP" pushbutton on the remote pushbutton station. If additional E-stops have been added, these also have to be released.
3. Operator presses the E-STOP RESET pushbutton. The red E-STOP light will turn off, the green E-STOP RESET pushbutton light will turn on, and the GUARD RESET pushbutton light will turn on.
4. Operator turns the MANUAL/AUTO selector switch to the AUTO position.
5. To operate the machine the amber-lighted GUARD RESET pushbutton must be pressed. If the photo eyes are clear the GUARD RESET pushbutton light will turn off. The machine is ready to operate.

6. Operator places a container inside the enclosure and sets the retention bar. This process will disrupt at least one of the Guard Photo Eyes.
7. Operator leaves the enclosure and presses the GUARD RESET pushbutton. If the photo eyes are clear the GUARD RESET pushbutton light will turn off. The machine is ready to operate.
8. Operator presses one of the UP pushbuttons. The operator must hold the pushbutton for one second. During this one second, the motion alarm will flash and beep. After holding the pushbutton for one second, the enclosure rises to the Tilt up (PRS1) proximity switch and stops. The operator does not have to hold the button during this first stage of motion. The alarms will continue to flash and beep as long as the machine is in motion.
9. To tilt the enclosure and dump the contents, the operator must press and hold one of the UP pushbuttons until the machine has tilted to the desired dump position. The operator must hold the push button for three seconds before the machine will start to move. During these three seconds, the motion alarm will flash and beep. If the operator releases the UP pushbutton, the machine will stop movement, and the operator will have to hold the pushbutton for three seconds before the machine will tilt again. This prevents rapid jogging of the machine. This process may be repeated until the tilt frame reaches the Dump up (PRS3) proximity switch.
10. If the enclosure is not at the Dump up (PRS3) or Dump down (PRS4) proximity switches, the DOWN pushbuttons can be used to tilt the enclosure down without returning the machine to full down. The operator must hold the pushbutton for three seconds before the machine will start to tilt. The machine will stop when either the DOWN button is released, or the Dump down (PRS4) proximity switch is reached.
11. To return the machine to full down, the operator presses the DOWN pushbutton. The operator must hold the pushbutton for three seconds. During this time, the motion alarm will flash and beep. After holding the pushbutton for three seconds, the machine will tilt the enclosure back to the Dump down (PRS4) switch.
 - If the machine is at either the Dump up (PRS3) or Dump down (PRS4) switches the DOWN button doesn't have to be held after motion begins. The machine will lower to the Dump down (PRS4) switch, wait for a half second, and then the enclosure will lower to the Tilt down (PRS2) switch.
 - If the machine is not at the Dump up (PRS3) or Dump down (PRS4) switches, the operator will hold the DOWN button until the machine reaches the Dump down (PRS4) switch, release the DOWN button, and then press it again for three seconds to start the machine lowering to the Tilt down (PRS2) switch. Once the motion starts, the operator does not have to hold the button. The motion alarm will continue to flash and beep as long as the machine is in motion.

5.4 Manual Mode

There are two uses of the MANUAL mode.

1. To stop and correct and automatic motion started in error. Turning the MANUAL/AUTO switch to the MANUAL position will stop the automatic motion. The machine can be manually operated with the UP or DOWN pushbuttons to return the machine to a particular starting position.
2. The second use is for qualified personnel to test and diagnose problems with the machine by use of the UP or DOWN pushbuttons.

5.5 Run Time Fault Sequence

If any motion takes longer than 20 seconds, a Run Time Fault has occurred. The fault could be caused by a tripped overload relay, blown fuses, damaged hydraulic lines, faulty valve, damaged wiring, or a damaged or faulty proximity switch.

Once a Run Time Fault is detected, all machine motion stops, and the lighted GUARD RESET pushbutton will flash. Qualified personnel should examine and check the machine for the cause of the problem before it is returned to operation. After the problem has been corrected, the machine can be reset by turning the MANUAL/AUTO switch to the MANUAL position and pressing the GUARD RESET pushbutton for 5 seconds. The light will turn off, and machine operation can be resumed.

DANGER

High Voltage can cause severe injury or death. Lock-out/tag-out the power source before performing maintenance or repair.

Only trained and/ or qualified personnel shall perform and maintenance or repair.

Pressurized fluids can penetrate skin and cause severe injury or death. Always use proper personal protective equipment when repairing or maintaining pressurized systems. Relieve hydraulic system pressure before performing any maintenance on the hydraulic system. Treat all lines as if pressurized and open any necessary fitting slowly and do not completely disconnect until all pressure has been relieved. See Relieving Hydraulic Pressure and Torque Requirements for Hydraulic Hose Connections sections.

Pinch points, shear points and crush hazards exist when operating the machine. Do not enter under any equipment while testing or operating the machine. Keep hands, feet, and loose clothing away from moving equipment.

Do not enter into the load area when load enclosure is raised.

Do not enter beneath the raised load enclosure.

If a hydraulic fitting becomes loose or if a hydraulic hose breaks, the hydraulic fluid will escape from the system under pressure. If the machine is elevated when this happens, it will drop very quickly. Someone may be hurt or the product or machine may be damaged.

Do not change the setting on the relief valve in the pump. If you do, this may damage the machine and you may be hurt. The relief valve has been included for the protection of all the workers who use the machine.

If damage or excessive wear is found, remove the machine from service until the machine is repaired.

All maintenance to be performed with the load enclosure in the fully lowered position.

See Torque Requirements for Hydraulic Hose Connections section when making or tightening any hydraulic hose connections.

⚠ CAUTION

The APCU Support stands must not be used for hydraulic, electrical, or mechanical maintenance. See Optional Support Stand Use Procedure section.

The warning labels on the machine are there for the safety of the operator. If the labels are worn or missing, replace them.

Use hydraulic fluid as specified by Southworth with the correct grade and properties for the existing operating conditions.

It is very important to keep the hydraulic oil free from dirt, dust, metal chips, water and other contamination. Most of the problems with hydraulic systems are caused by contamination of the oil.

⋮
⋮ Maintenance items referring to the control panel, operator controls, or associated
⋮ wiring are only applicable to third generation stand-alone APCU.
⋮

6.1 Torque Requirements for Hydraulic Hose Connections

Tighten the (10) each 3/4-16 JIC swivel fittings at the external HPU and on the APCU to 38-42 ft./lbs. and the (2) each 9/16-18 JIC swivel fittings on the APCU to 18-20 ft./lbs. Do not over tighten.

APCU HPU DUMP UP
3/4-16 (38-42 ft./lbs.)

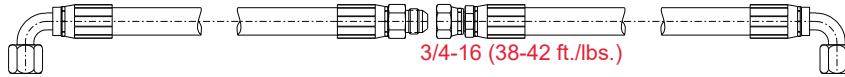

APCU UNLOADER DUMP UP
3/4-16 (38-42 ft./lbs.)

APCU HPU DUMP DOWN
3/4-16 (38-42 ft./lbs.)

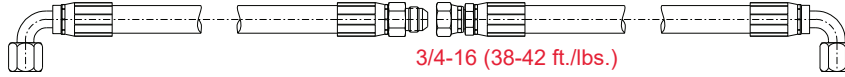

APCU UNLOADER DUMP DOWN
3/4-16 (38-42 ft./lbs.)

APCU HPU TILT UP
3/4-16 (38-42 ft./lbs.)

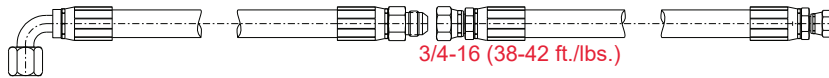

APCU UNLOADER TILT UP
9/16-18 (18-20 ft./lbs.)

APCU HPU TILT DOWN
3/4-16 (38-42 ft./lbs.)

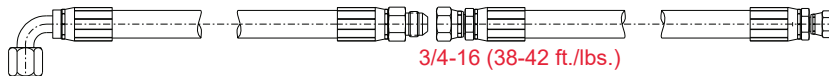

APCU UNLOADER TILT DOWN
9/16-18 (18-20 ft./lbs.)

Any other 9/16-18 fittings not illustrated above within the APCU (as at cylinders or internal bulkheads) should be tightened to 18-20 ft./lbs.

6.2 Periodic Maintenance

Before each use:

- Inspect the machine for excessive wear or damage.
- Verify all precautionary labeling is in place and legible.
- Verify all three photo eyes across the load enclosure opening are functioning correctly. **See Item 7 of testing procedure.**
- Verify the machine moves smoothly through the tilt up/down and dump up/down movements.
- Verify Grace Voltage indicator, located on the cover of the control panel is functioning. The LED for L1, L2, and L3 should be illuminated. If the ground led is illuminated, there is a ground fault condition that must be corrected before continuing.

6.2.1 Weekly Maintenance

- Inspect all hydraulic fittings and hoses for excessive wear or damage. Ensure fittings are tight.
- Inspect all fasteners, ensure they are tight.
- Verify all proximity switches are properly adjusted. **See items 8-10 of the testing procedure.**

6.2.2 Monthly Maintenance

- Perform all weekly maintenance.
- Inspect all pivot pins and bushings and cylinder clevis pins and bushings for excessive wear or damage.
- Inspect all wiring, control panel buttons and switches, and push-button controls for damage or loose connections.
- Inspect the hydraulic fluid. If the fluid is dark or cloudy or contains any debris change the fluid and fluid filter. Verify proper fluid level through sight glass on side of the reservoir.
- Inspect base frame, tilt frame, and load enclosure for excessive wear, damage, and broken welds.

6.2.3 Every Six Months or 500 Hours of Operation

- Perform all monthly maintenance.
- Replace hydraulic fluid filter. Replace fluid as necessary. If fluid is to be replaced, thoroughly clean the reservoir and suction screen.

NOTICE

Uncontaminated hydraulic fluid should be replaced annually.

The fluid filter should be changed when the indicator needle is no longer in the green region of the gauge.

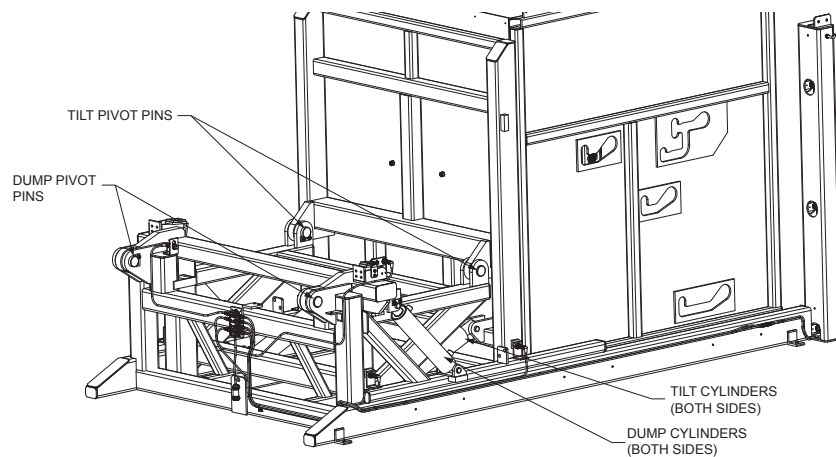

6.3 Adjusting Proximity Sensors

6.3.1 Setting End of Travel for Tilt Down Function

This proximity switch (PRS2) is located on the mid-point of one side of the machine base. The target for this switch is located on the bottom back outside corner of the load enclosure.

1. Set the unit so that the loading edge of the load enclosure is just touching the floor.
2. Position this switch so that the load enclosure stops lowering when the front lip of the load enclosure just contacts the floor. When the load enclosure reaches this limit, the switch should send a signal to stop the motor on the hydraulic power unit.

NOTICE

⋮
⋮ **Do not allow the load enclosure to power into the floor.**

⋮
⋮ **If high points in the floor prevent the front lip of the load enclosure from coming in contact with the floor the base frame must be shimmed and re-leveled. High points must not create a need for more than 1/4" of shimming at any point. See Pre-Installation section.**

6.3.2 Setting End of Travel for Tilt Up Function

This proximity switch (PRS1) is located on the top outside edge of the tilt frame. It is positioned close to the discharge end of the machine. The target for this switch is located on the top back outside edge of the load enclosure.

Set this switch so that the tilt function of the load enclosure stops just as the frame of the load enclosure touches the stop pads, or just a moment before. When the load enclosure reaches this limit, the switch should send a signal to stop the motor on the hydraulic power unit. A clearance of 1/8" from the pads is acceptable.

NOTICE

⋮
⋮ **Do not allow the tilt frame to power or crash into the stop pads or the machine may not operate as intended. Powering into the stop pads may cause damage to the machine.**

6.3.3 Setting End of Travel for Dump Up Function

This proximity switch (PRS3) is located on top of the back upright tube of the base frame. The target for this switch is located on the top back side of the tilt frame.

Position this switch so that the load enclosure stops dumping at the desired angle. When the load enclosure reaches this limit, the switch should send a signal to stop the motor on the hydraulic power unit.

6.3.4 Setting End of Travel for Dump Down Function

This proximity switch (PRS4) is located on top of the base tube of the base frame, toward the dump side of the machine. The target is located on the bottom back outside of the tilt frame.

Position this switch so that, at the end of the dump down cycle, the bottom of the tilt frame rests on the cross tube at the dump end of the base frame.

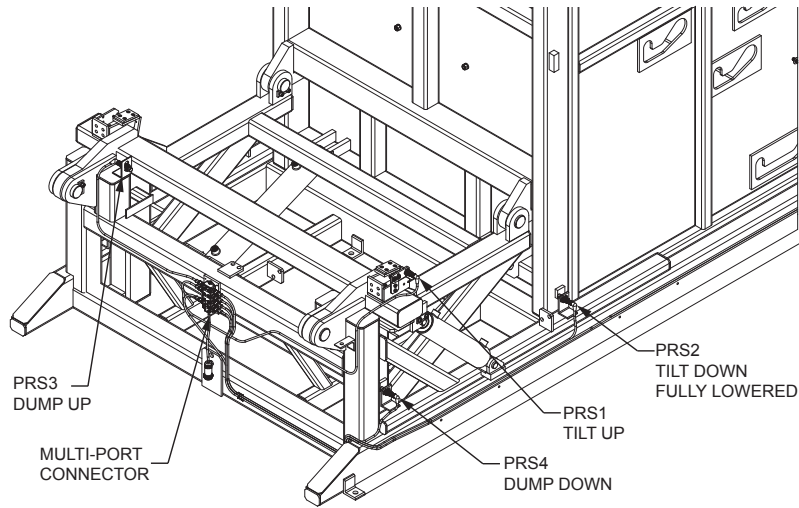

NOTICE

Do not allow the tilt frame to power or crash into the base frame or the machine may be damaged.

If the load enclosure interferes with the conveyor when in the dump down position, the dump down hard stops can be reconfigured to raise the load enclosure and help prevent interference. See section 6.3 Alternate Dump Down Hard Stop Positioning.

6.4 Alternate Dump Down Hard Stop Positioning

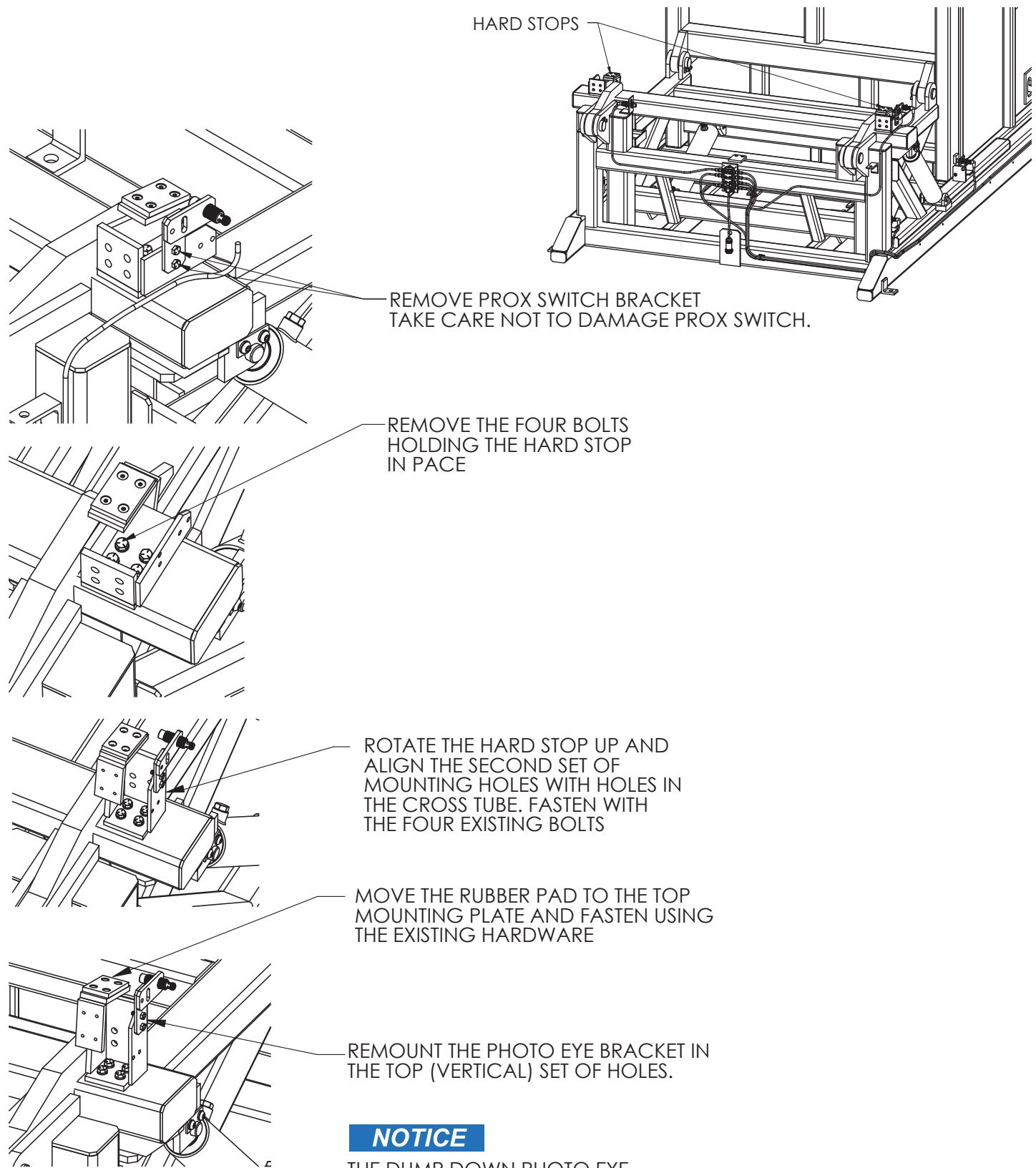

NOTICE

THE DUMP DOWN PHOTO EYE WILL NEED TO BE ADJUSTED TO ACHIEVE THE CORRECT DUMP DOWN POSITION. SEE SECTION 6.2 ADJUSTING PROXIMITY SENSORS.

6.5 Inspecting and Cleaning a Control Valve

1. Check that the valve is receiving the correct control voltage. When the valve is supposed to be energized, the solenoid should receive 24V DC.
2. Check the continuity through the solenoid coil. With the power off, check the resistance through the coil using an ohmmeter. There should be a low resistance (a few Ohms). If the meter shows no resistance, the coil may be shorted. Substitute a coil which is known to be good. If the meter shows an infinitely high resistance, the coil should be replaced.
3. Each valve used on this machine is designed with a solenoid coil which can be changed without removing the valve or spilling any hydraulic fluid. To change the solenoid:
 - Disconnect the plug on the top of the solenoid.
 - Remove the retainer nut and O-ring.
 - Slide the coil off of the tube.

DANGER

High pressure fluids can penetrate skin and cause severe injury or death. Always relieve hydraulic system pressure before performing maintenance or repair of the hydraulic system. See Relieving Hydraulic Pressure and Torque Requirements for Hydraulic Hose Connections sections.

4. To clean the parts on the valve spool, you must remove it from the spool body. Depressurize the hydraulic system by lowering both lifting mechanisms completely. Be sure to turn off the power to the machine and relieve hydraulic pressure.
5. Unscrew the tube. Remove the spool and inspect it for debris which could block the valve action. Clean the spool as required. Before reassembly, verify that the inside of the valve body is clean and free of debris.
6. Reassemble the valve. The retainer nut should be finger tight only. Press the plunger in both directions by hand several times to be sure it moves freely.

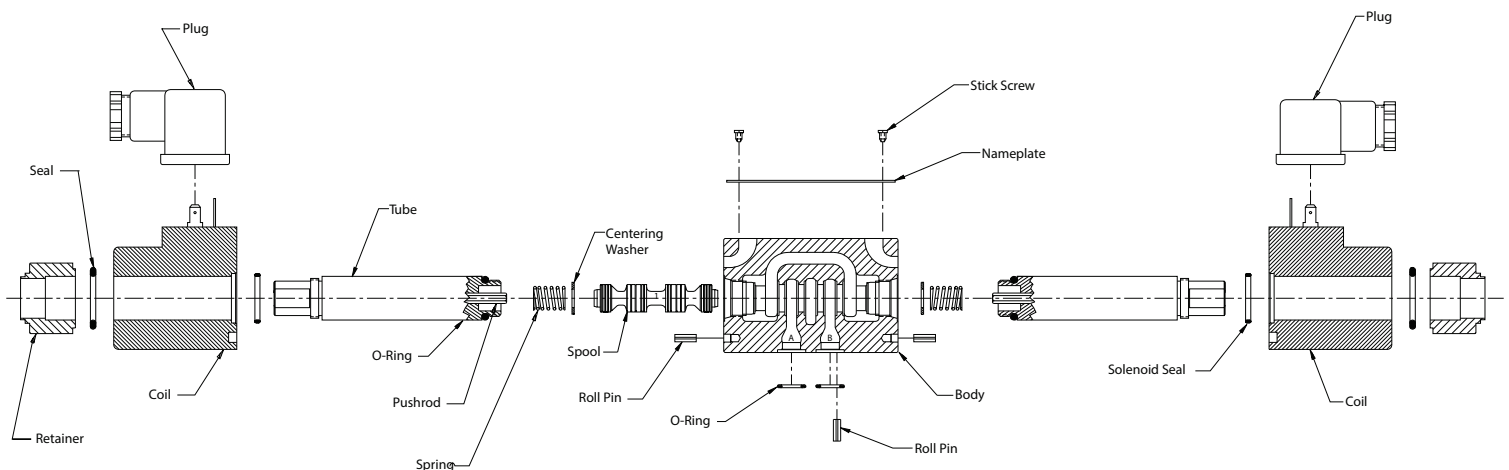

6.6 Relieving Hydraulic Pressure

1. Lower the load enclosure to the fully lowered position. This will relieve pressure between the reservoir and the counter-balance valves, within the valve manifold. The lines between the counter-balance valves and cylinders will still be pressurized.
2. Disconnect the main power to the machine by turning the main disconnect switch on the control panel to the OFF position. Verify power has been disconnected with the Grace voltage indicator on the control panel. All LED lights should be off.
3. To relieve the pressure between the counter-balance valves and the cylinders, the lines from the cylinders to the valve manifold need to be loosened.

DANGER

High pressure fluids can penetrate skin and cause severe injury or death. Always relieve hydraulic system pressure before performing maintenance or repair of the hydraulic system.

If the load enclosure is stuck in the raised position the tilt frame and load enclosure must be blocked up before relieving pressure to prevent it from falling, uncontrolled, when the pressure is released. Do not enter beneath the raised load enclosure.

See Torque Requirements for Hydraulic Hose Connections section when making or tightening any hydraulic hose connections.

The pressure gauge mounted on the hydraulic power unit does not indicate pressure in the hoses from the manifold to the cylinders when the motor is not running.

4. Loosen each hose fitting, one at a time, from ports A, B, C, and D in the valve manifold, allow the pressure to vent and re-tighten fitting. See **Torque Requirements for Hydraulic Hose Connections** section when making or tightening any hydraulic hose connections. Use clean container rags to catch any fluid that may leak.

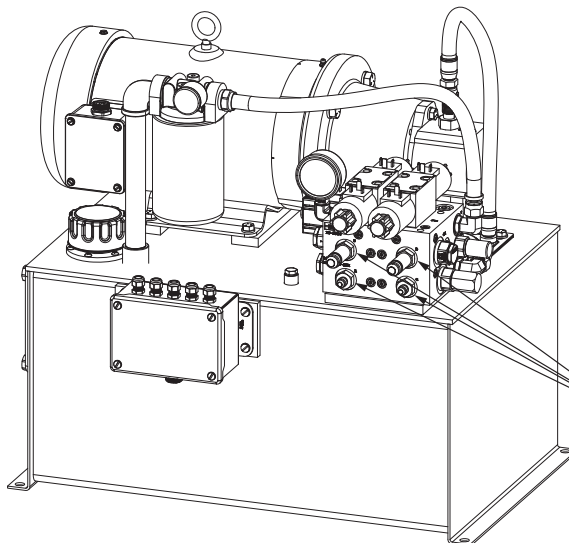

LOOSEN EACH FITTING, ONE AT A TIME. ALLOW PRESSURE TO VENT. RE-TIGHTEN FITTING.

5. After performing required maintenance/repair, verify that all connections are tight.
6. Turn the main disconnect switch to the ON position. Raise and lower the machine to test for correct operation. Check for leaking around fittings and in hoses.
7. Raise and lower through the full cycle five to six times to bleed any air from the hydraulic system. Check the fluid level in the reservoir after the machine has been cycled and has been returned in the fully lowered position. Refill with clean fluid as necessary.

6.7 Hydraulic Cylinder Repair & Replacement

DANGER

All maintenance must be performed with the load enclosure in the fully lowered position.

Lock-out/tag-out electrical power before performing any maintenance.

High pressure fluids can penetrate skin and cause severe injury or death. Always relieve hydraulic system pressure before performing maintenance or repair of the hydraulic system. See Relieving Hydraulic Pressure section.

Hydraulic Cylinders are heavy. To avoid strains or back injury use lifting aids and proper lifting techniques when removing and/or replacing.

6.7.1 Removing Cylinders

1. Disconnect the hydraulic supply line to the bottom end of the cylinder. Place the free end into a container to collect the used oil.
2. Repeat the same procedure for the hydraulic supply line to the top end of the cylinder.
3. At the top end of the rod remove the keeper from the upper cylinder clevis and drive out the upper clevis pin. Repeat the same procedure to remove the lower cylinder clevis pin.
4. Now the cylinder can be removed for repacking or replacement.
5. Fluid in the rod end of the cylinder can be drained by tipping the cylinder up over a container and allowing the fluid to drain from the rod end port.

6.7.2 Repacking Cylinder

NOTICE

Cylinder repacking should be completed by trained and/or qualified personnel only.

Keep all parts clean and free of debris at all times. Contaminated parts can cause damage to the hydraulic system when placed back into operation.

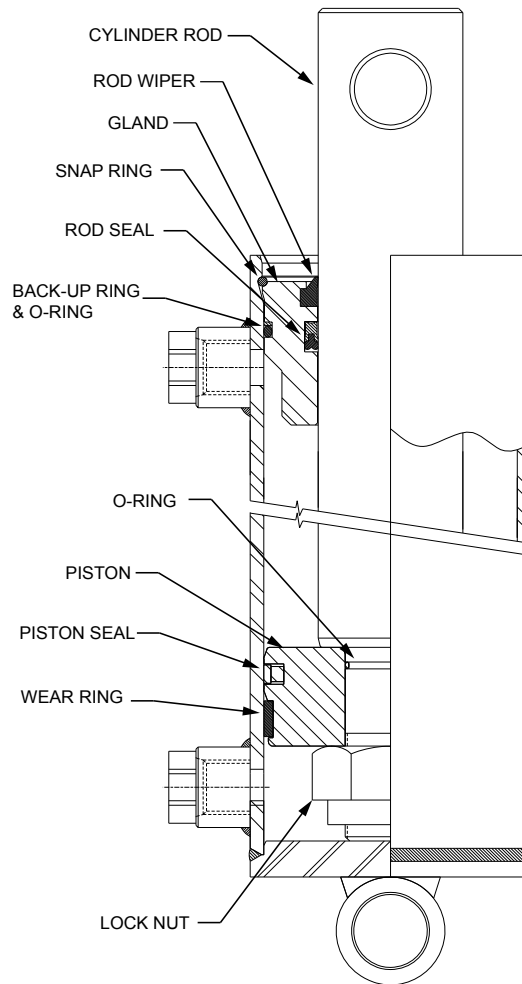

With the cylinder removed and secured in a vice:

1. At the upper end of the cylinder, remove the snap ring. Pull the rod to within 3 inches of full extension. Compress the ring and, at the same time, pull outward on the rod. This will pull the gland out of the cylinder.
2. Pull the rod and piston all the way out of the cylinder. This assembly is heavy! Be careful not to drop it as it comes free.
3. Remove the piston from the cylinder rod. (Be careful to protect the cylinder rod as you do this. Any burrs on the rod could damage the packing.) Note the position of the piston ring and remove it. Remove the wear ring and piston seal from the piston. Remove the smaller O-ring which fits around the cylinder rod.

4. Remove the gland from the cylinder rod by sliding it off the end which holds the piston. Notice how the wiper ring sits in the gland. Note the position of the rod seal. Remove the rod wiper and rod seal from the gland.
5. Clean all of the surfaces on the gland. Install a new rod seal. Install a new rod wiper in the correct orientation. Coat the inner diameter of the gland with light grease and replace it on the rod.

NOTICE

⋮
⋮
⋮
⋮
⋮
Be careful not to install the wiper backwards.

6. Clean the piston surfaces. Install a new O-ring and wear ring on the piston. Install a new piston seal. Attach the piston to the rod and tighten the lock nut to 150 Ft. Lb.
7. Clean the bore of the cylinder tube thoroughly. Inspect the bore of the tube for scratches which run up and down, along the length of the cylinder. If you do see any scratches, hone the inner surface of the cylinder. Be sure to clean the tube thoroughly after you do this.
8. Lubricate the inner diameter of the cylinder tube with a light coating of hydraulic oil. Carefully insert the piston and rod back into the cylinder. Be very careful not to damage the piston seal, O-ring, or wear ring as you do this. It may be helpful to tip the rod assembly and twist it as you slide it into the cylinder. Once the piston is inside the cylinder, it should slide easily.
9. Slide the gland assembly into the cylinder. Rotate the gland so the port lines up with the hole in the cylinder tube. Install a new snap ring. Compress the snap ring, tap the gland into place, then relax the snap ring. Be sure that the snap ring is in place in the groove.
10. Install the cylinder in the unit as described below.

6.7.3 Replacing a Cylinder

1. Align the lower cylinder with each lower cylinder clevis and insert the lower cylinder clevis pin. Be careful! The cylinder is heavy! Replace the keeper and secure it with the button-head cap screws (supplied). Repeat the same procedure to replace and secure the clevis pin for the upper cylinder.
2. Attach the lower and upper hydraulic supply lines.
3. Be sure everyone is clear of the equipment. Turn on the power and test the unit. Run the mechanism through five to six cycles to completely purge any air trapped in the hydraulic lines.
4. Lower the load enclosure to the fully lowered position. Check hydraulic fluid level in the reservoir. Add fluid as necessary.

6.8 Ordering Replacement Parts

Southworth has carefully chosen the components in your lift to be the best available for the purpose. Replacement parts should be identical to the original equipment. Southworth will not be responsible for equipment failures resulting from the use of incorrect replacement parts or from unauthorized modifications of the machine.

Southworth offers replacement parts for your Southworth machine. With your order, please include the model number and the serial number of the machine. When you are ordering parts for a cylinder, also include the cylinder number. This is stamped on the base of the cylinder housing.

To order replacement parts, please call the Parts Department. See Warranty & Contact Information section.

Parts are shipped subject to the following terms:

- FOB factory
- Returns only with the approval of our parts department.
- Payment net 30 days (except parts covered by warranty).
- Freight collect (except parts covered by warranty).
- The warranty for repair parts is 30 days from date of shipment.

Parts replaced under warranty are on a “charge-credit” basis. We will invoice you when we ship the replacement part, then credit you when you return the worn or damaged part, and we verify that it is covered by our warranty. Labor is not covered under warranty for Parts orders.

7 TROUBLESHOOTING

NOTICE

⋮ Troubleshooting items referring to the control panel, operator controls, or
 ⋮ associated wiring are applicable to only third generation stand-alone APCUs.
 ⋮

Problem	Possible Cause	Check
Neither lift mechanism is working: If the tilt function does not begin right away, don't continue to operate the "up" control for more than 2 or 3 seconds. You may damage the pump.	Machine may not be powered.	Verify the supply voltage to the control panel is correct. Verify main disconnect switch is in the ON position and the control panel is receiving power with the Grace voltage indicator. See Electrical section.
	One or more of the fuses may have opened.	Inspect fuses. Determine and repair the cause and replace as necessary.
	Emergency stop button may be pressed.	Verify the emergency stop button has been pulled out.
	One or more of the photo eyes may be obstructed.	Verify there are no obstructions. Verify that the LED on the photo eyes is illuminated and that the guard reset is operating correctly.
	The HPU motor's over-current protection may be activated.	Check if the overload relay has been tripped. Manually reset if necessary.
	Something may be preventing the motor from turning.	Verify nothing is preventing the motor from turning. Possible seized pump or bad coupling.
	The motor may be turning in reverse.	If this is happening, the pressure valve will indicate zero pressure even though the motor is running. Reverse any two electrical leads on the motor.
	The motor may be "single phasing".	This causes the motor to hum, but not turn. Check for a break in one lead to the three-phase motor. Check the motor wiring and line fuses.
	The voltage to the motor may be too low.	Check the voltage at the starter when the motor is under load. The supply voltage should be within $\pm 10\%$ of the rating.
	The level of the hydraulic oil may be low.	When the unit is lowered completely, check the oil level by viewing the reservoir sight gauge.
The filler/breather cap on the hydraulic tank may be plugged.	Remove the cap and clean the baffles inside it.	

Problem	Possible Cause	Check
Neither lift mechanism is working: If the tilt function does not begin right away, don't continue to operate the "up" control for more than 2 or 3 seconds. You may damage the pump.	There may be a vacuum leak in the suction line. (This could cause cavitation and loss of suction in the pump.)	Check the suction line hose and fittings. Do not allow cavitation to continue -- this may damage the pump.
	The coupling between the pump and motor may be missing or loose.	Remove the pump and check to see that the coupling is in place and properly fastened.
	The hydraulic pump may be defective.	Replace as necessary.
	The hydraulic valves may not be operating correctly.	Verify the solenoids are receiving correct power. Manually shift the valves in both directions to check if valves may be stuck.
The load enclosure will not tilt up.	The PRS1 proximity switch for the tilt up function may be out of adjustment.	Check the adjustment of the switch. See the Adjusting Proximity Switches section.
	The four-way valve may not be functioning correctly.	See the Inspecting and Cleaning a Control Valve section.
The tilt mechanism raises slowly.	The counter-balance valve in this circuit may be plugged.	Contact Customer Service for assistance.
The tilt mechanism does not lower. Do not enter under the raised load enclosure. See the Relieving Hydraulic Pressure section. The APCU Support stands must not be used for hydraulic, electrical, or mechanical maintenance.	The four-way valve may not be functioning correctly.	See the Inspecting and Cleaning a Control Valve section.
	One or more of the photo eyes may be obstructed.	Check if photo eyes are obstructed. Check if guard reset light is flashing. Clear any obstructions and press the GUARD RESET button.
When the load enclosure is lowered, the front lip down not rest on the floor.	The PRS2 proximity switch may be improperly aligned.	See the Adjusting Proximity Switches section.
	The base frame may not be properly leveled and shimmed.	Verify the base frame is level. See the Floor Conditions & Leveling Information and Lagging & Shimming Information sections.

Problem	Possible Cause	Check
The pump motor continues to run after the front edge (load edge) of the load enclosure touches the floor.	The PRS2 proximity switch may be improperly adjusted.	See the Adjusting Proximity Switches section.
The "Tilt Down" part of the cycle begins prematurely.	The tilt frame may be hitting the stop pads at the upper limit of travel too hard.	Adjust the PRS1 proximity switch. See the Adjusting Proximity Switches section.
The dump mechanism will not raise.	The PRS3 proximity switch for the dump lift function may be out of adjustment.	See the Adjusting Proximity Switches section.
	The four-way valve may not be functioning correctly.	See the Inspecting and Cleaning a Control Valve section.
The dump mechanism raises slowly.	The counter-balance valve in this circuit may be out of adjustment.	Contact Customer Service for assistance.
The pump motor continues to run after the load enclosure has reached the upper limit of the dump travel.	The PRS3 proximity switch may be out of adjustment.	See the Adjusting Proximity Switches section.
The dump mechanism does not lower.	The four-way valve may not be functioning correctly.	See the Inspecting and Cleaning a Control Valve section.
The dump mechanism lowers slowly.	The counter-balance valve in the circuit may be plugged.	Contact Customer Service for assistance

8 ELECTRICAL

Primary

460V 3 Phase 60 Hz

Control

24 VDC

Motor

5.0HP 6.7 Full Load Amps @ 460V

Primary power for the APCU is 460 volts, 3 phase, 60 cycle. It is recommended that each APCU has the facilities power supplied via a dedicated 15 amp fused disconnect with the fusing being of the slow blow type such as Buss FNQ-R-15.

Make connections between the facilities 15 amp fused disconnect and the APCU control panel per the recommended wire gauges below. In all cases ruling electrical codes must be followed.

Wiring Requirements

Minimum Recommended Wire Gauge

#14

#12

#10

#8

Run Length

Up to 60 feet

Up to 95 feet

Up to 150 feet

Up to 240 feet

NOTICE

- ⋮
- ⋮ **Insufficiently sized wiring for the given run could cause excess voltage drop at the**
- ⋮ **machine and cause input power fuses to blow.**
- ⋮

In cases where a different primary voltage is specified for the APCU, contact Southworth Customer Service for additional information.

NOTICE

- ⋮
- ⋮ **The following information in this section is applicable only to third generation**
- ⋮ **stand-alone APCU. For electrical information about APPS system APCU see**
- ⋮ **original Lockheed-Martin documentation.**
- ⋮

8.1 Sensor Arrangement

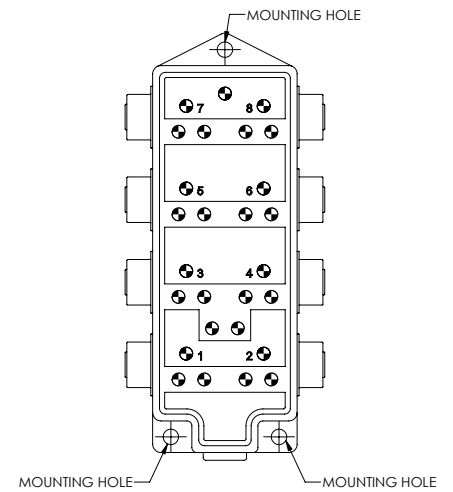
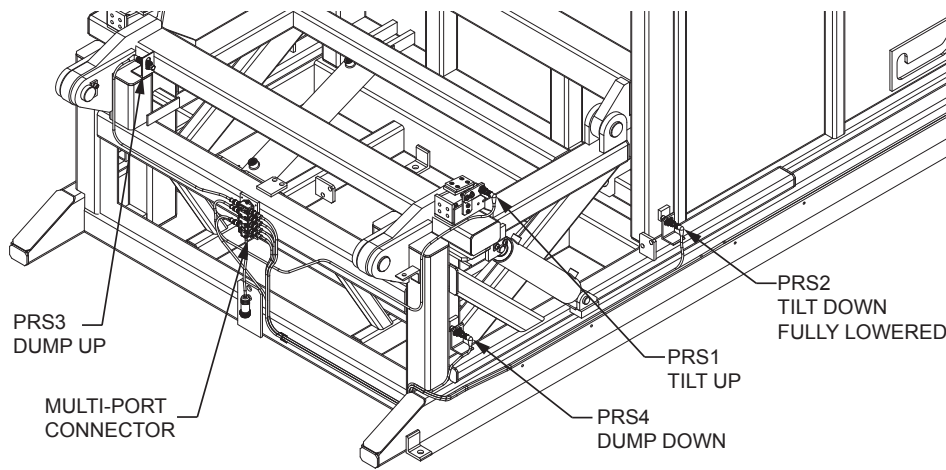

Typical multi-port connector

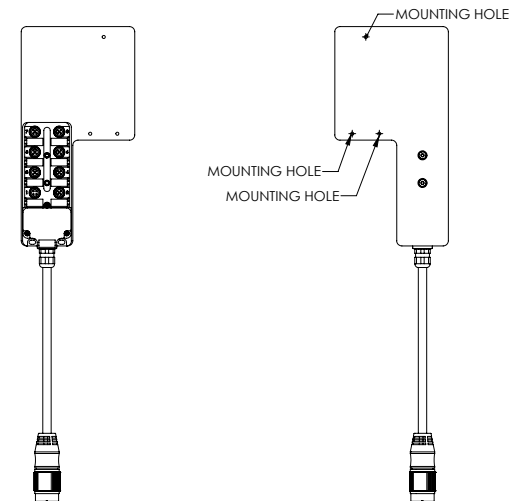
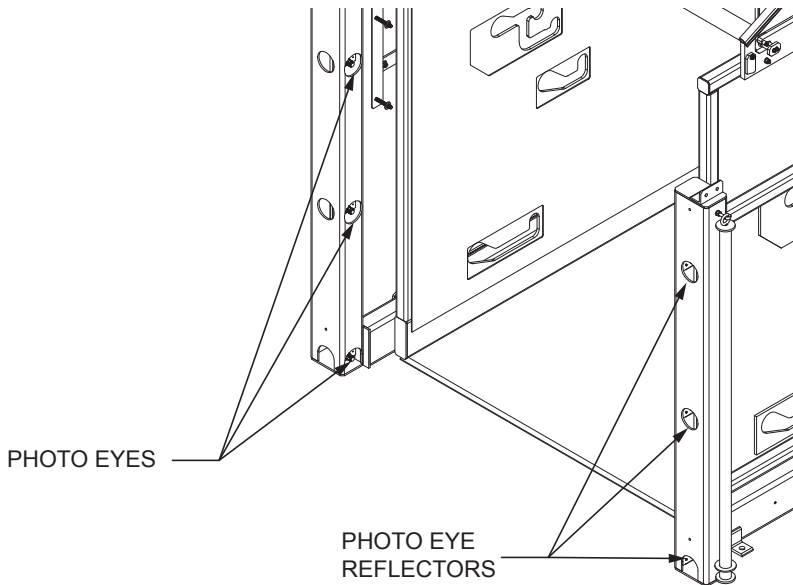

Alternative multi-port connector

Multi-Port Connector

Port	Sensor
1	Lower Photo Eye (PEC1)
2	Middle Photo Eye (PEC2)
3	Unused
4	Upper Photo Eye (PEC3)
5	Tilt Up Proximity Switch (PRS1)
6	Tilt Down Proximity Switch (PRS2)
7	Dump Up Proximity Switch (PRS3)
8	Dump Down Proximity Switch (PRS4)

Our typical multi-port connector is a outward facing unit with side mount connectors. Our alternative multi-port connector is an inward facing unit with front mount connectors. See images for mounting layouts. Ports are identical.

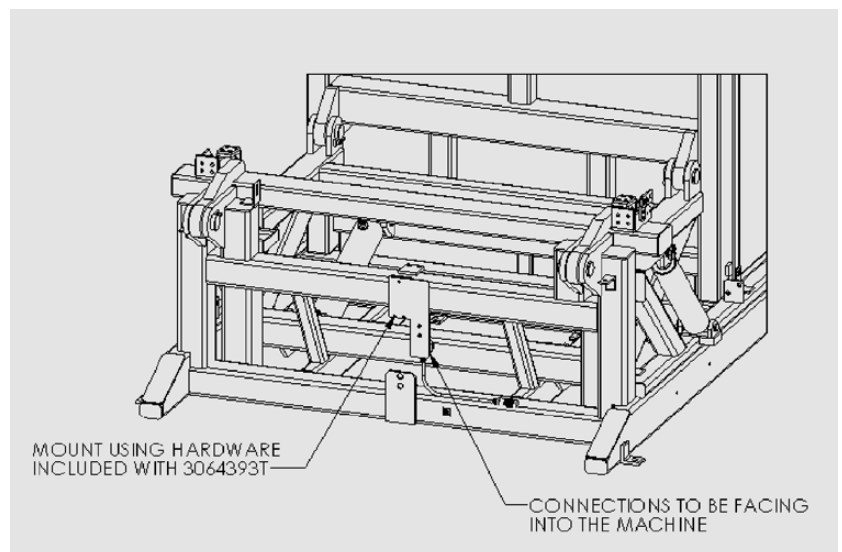

Alternative multi-port connector

8.2 Distinguishing Control Panels with PLC's Easy721-DC-TC vs Easy-E4-UC-12RC1

In May 2021, a transition to the Easy-E4-UC-12RC1 PLC began. To determine which PLC your unit has, see images below. Use the electrical schematic and PLC logic diagrams in this manual specific to the PLC type the APCU contains. Note that with either PLC, the unit's operation remains the same.

Easy721-DC-TC

(Began phase out May, 2021)

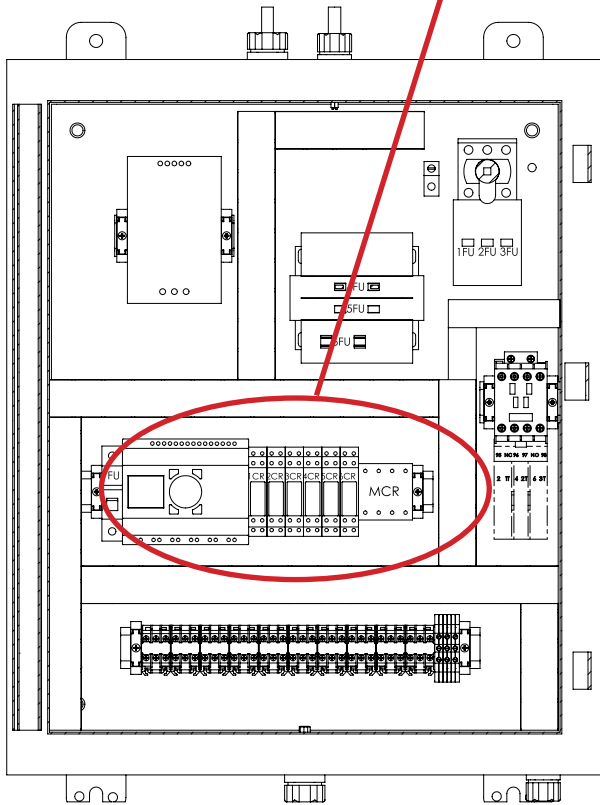

Easy-E4-UC-12RC1

(Began phase in May, 2021)

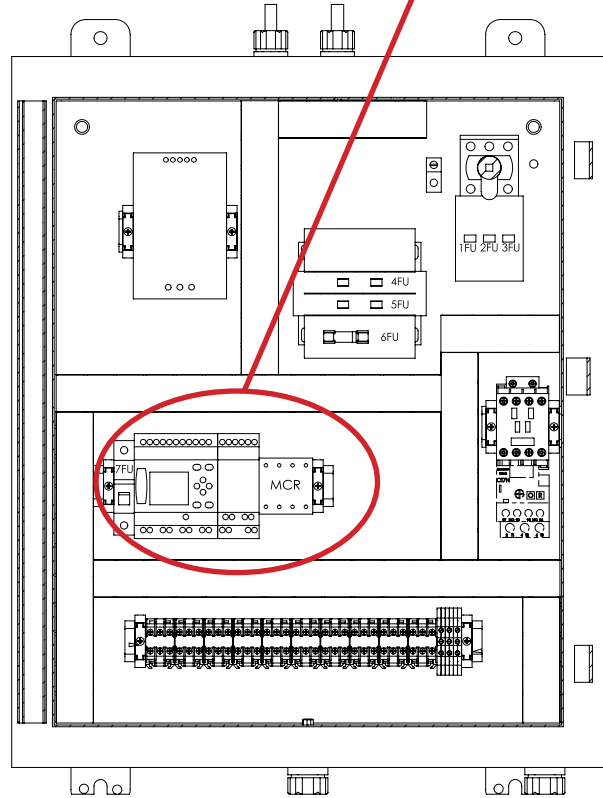

8.3 Wiring Schematic (Third Generation Stand-Alone APCU Only) - PLC (EASY721-DC-TC)

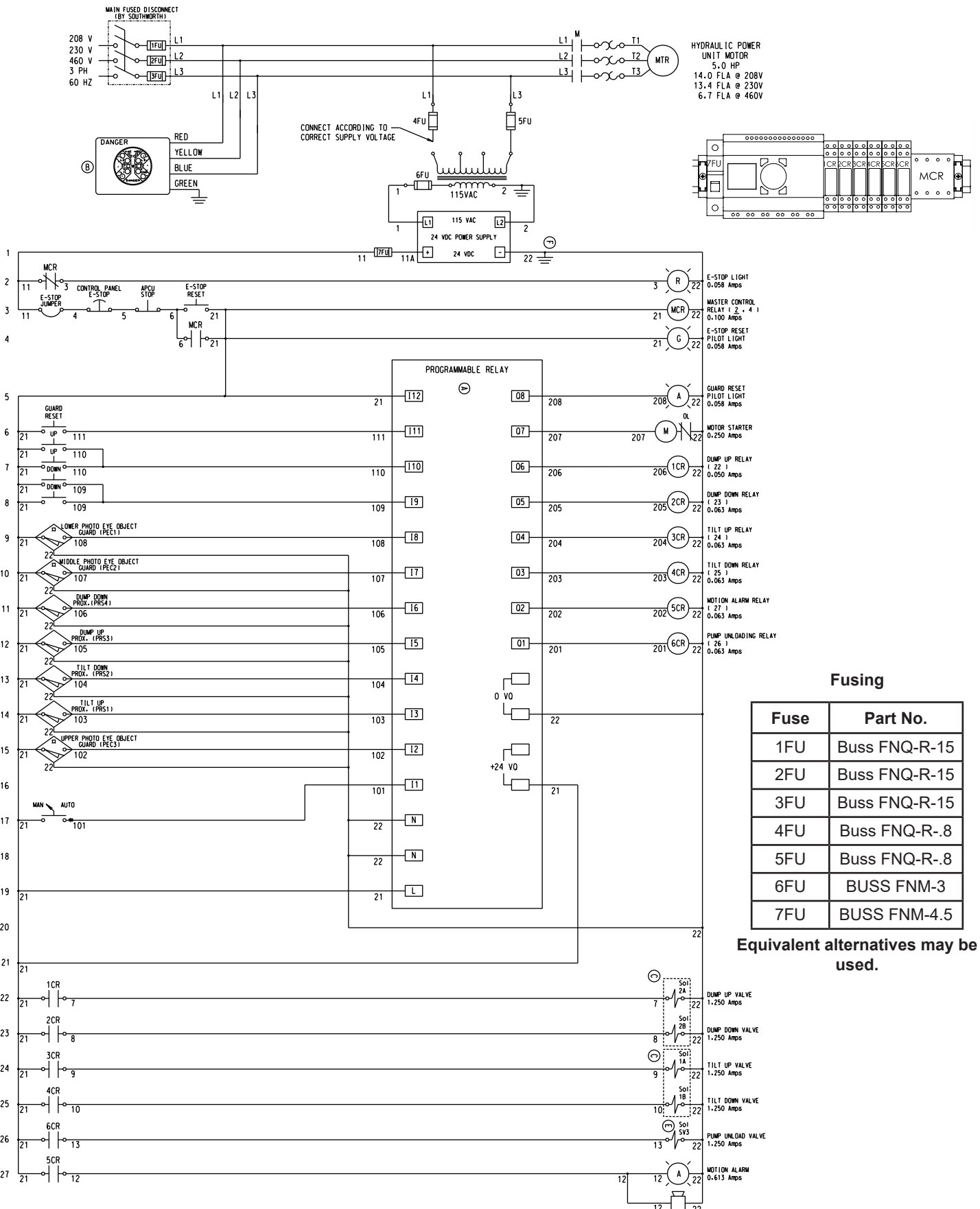

8.4 PLC Logic (Third Generation Stand-Alone APCU Only) - PLC (EASY721-DC-TC)

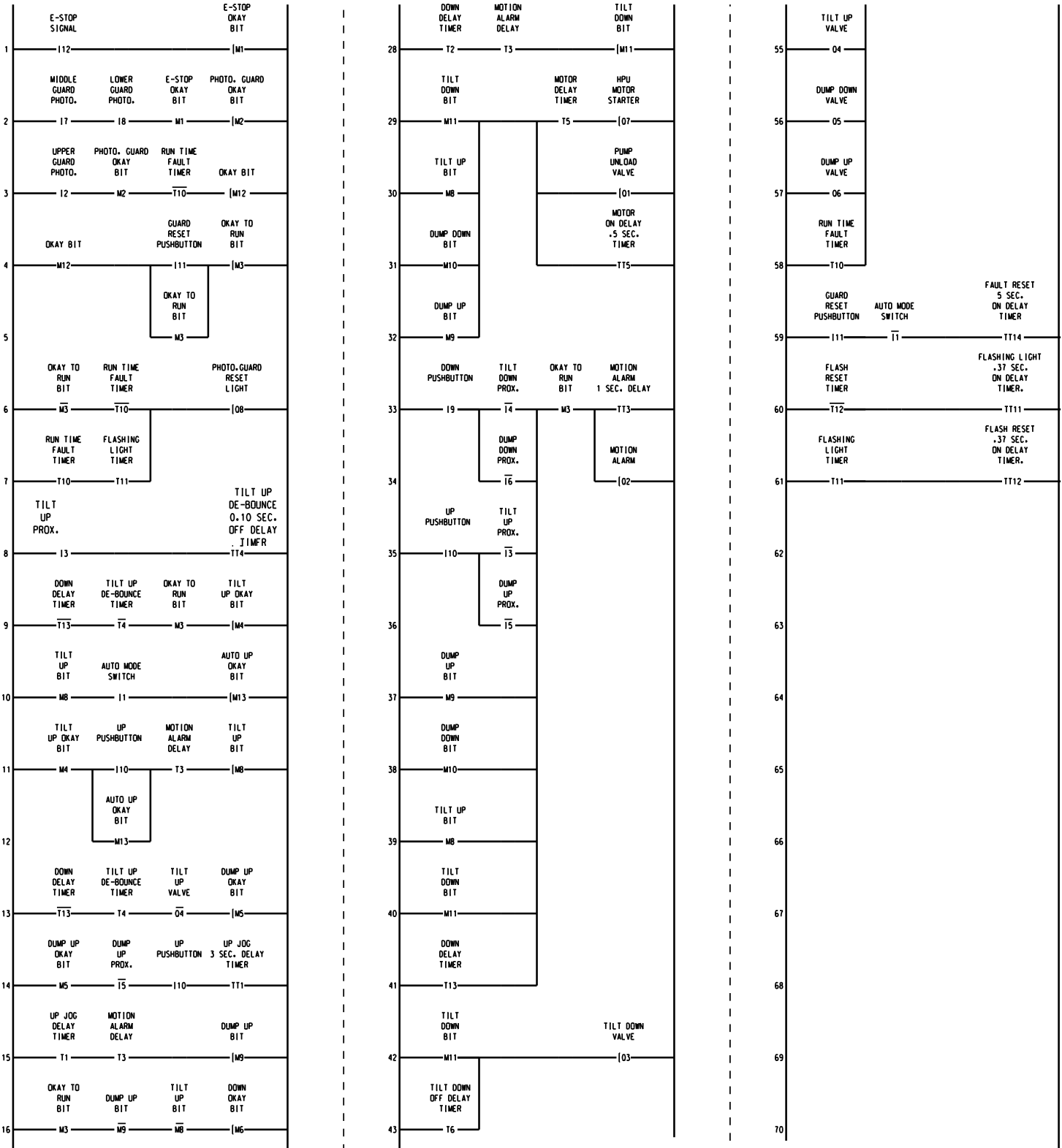

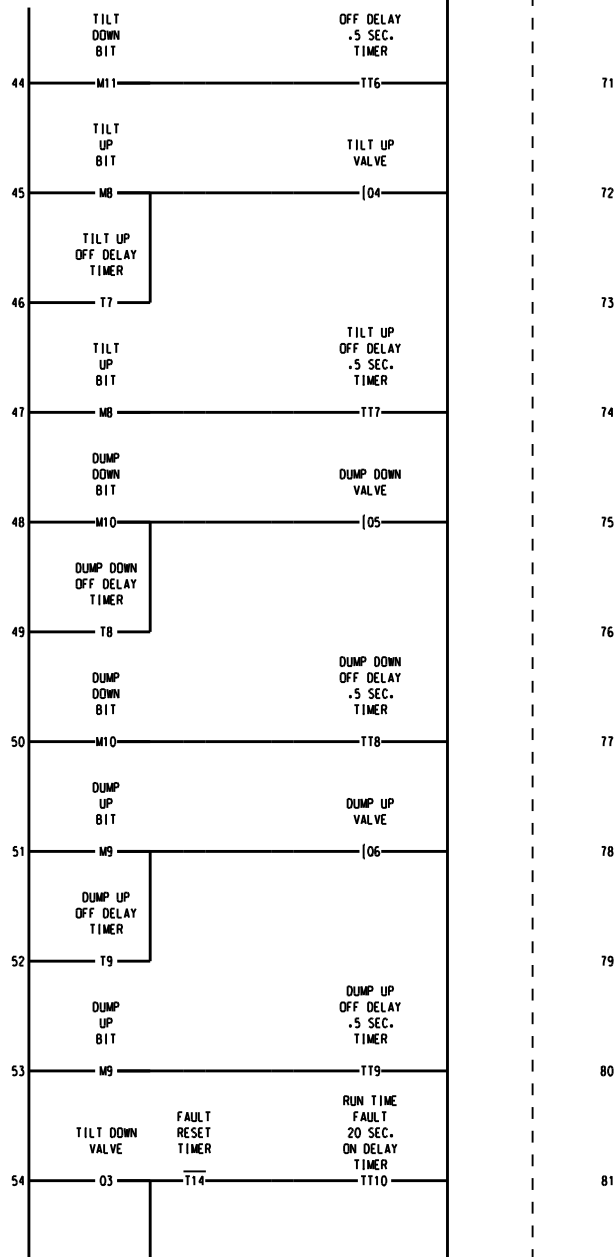
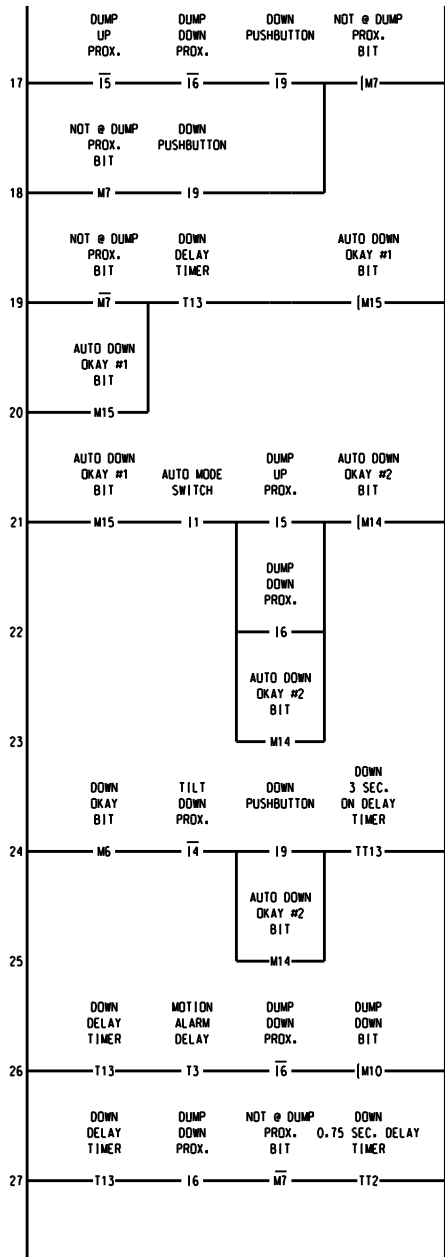

8.5 Wiring Schematic (Third Generation Stand-Alone APCU Only) - PLC (Easy-E4-UC-12RC1)

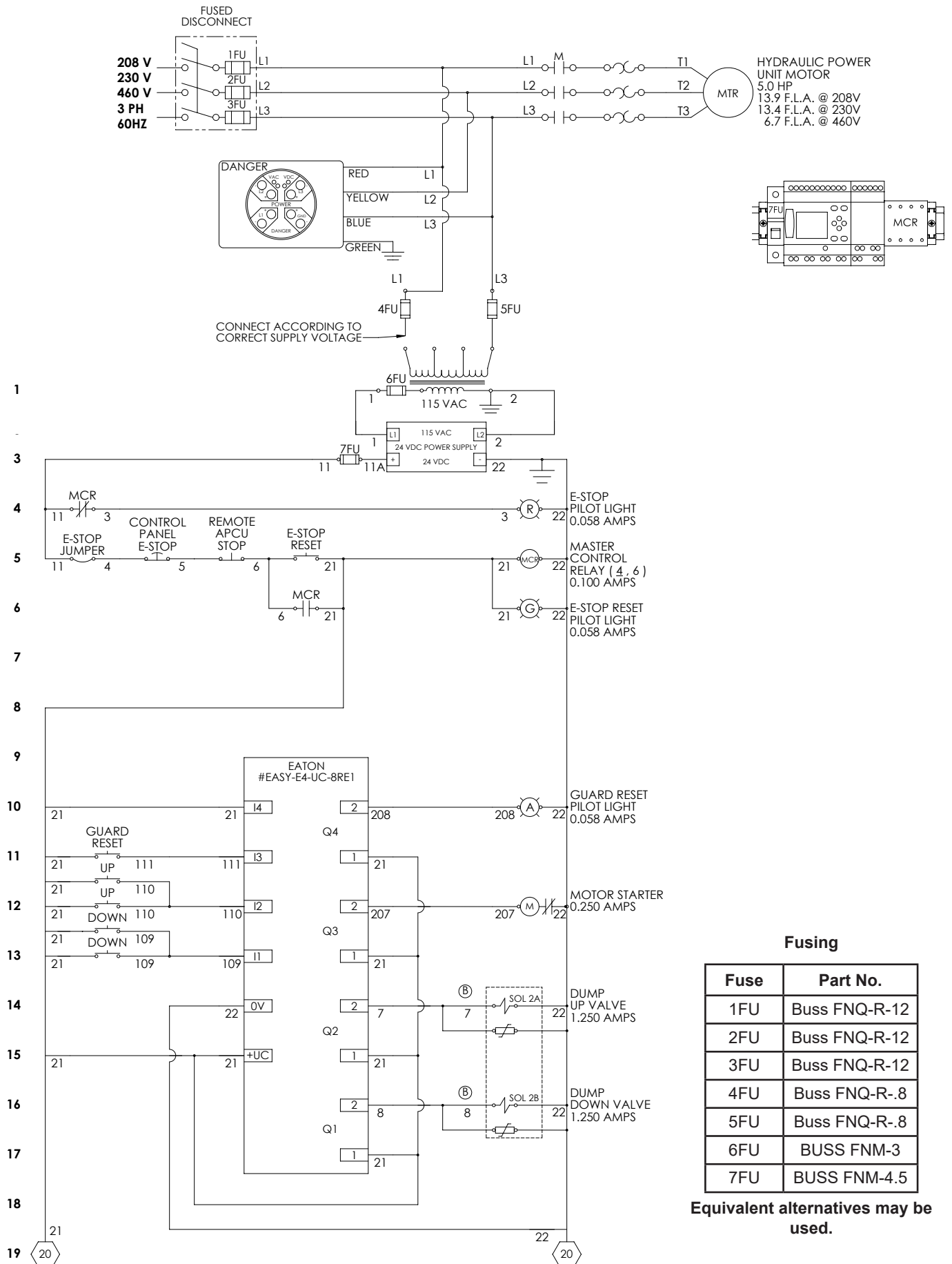

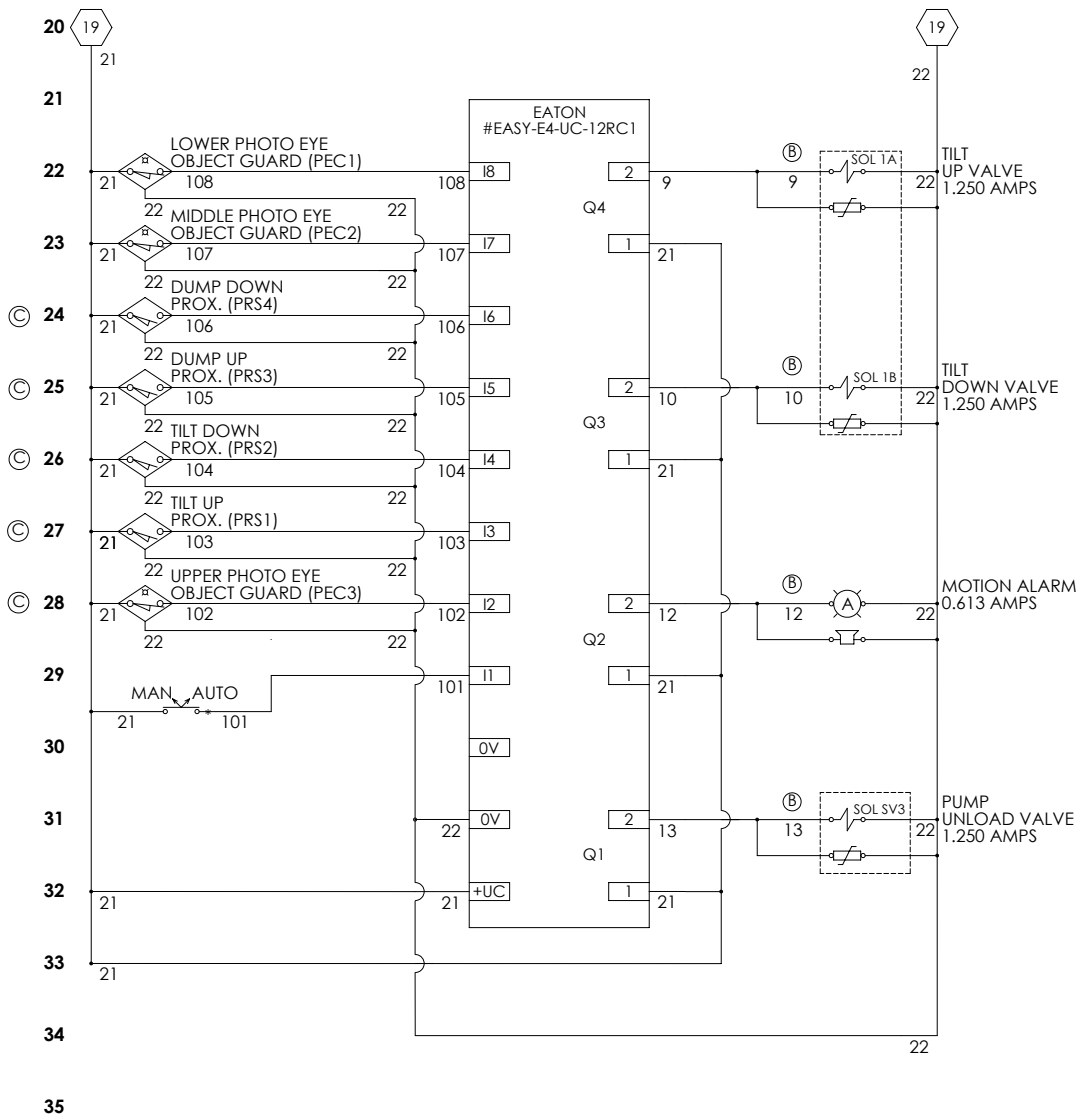

OPERATION NOTES:

1. TO OPERATE THE MACHINE, THE GREEN "E-STOP RESET" LIGHT MUST BE ON. THE "E-STOP RESET" LIGHT WILL ONLY TURN ON WHEN THE SYSTEM EMERGENCY STOP CIRCUIT IS CLOSED AND THE E-STOP RESET PUSH BUTTON IS OPERATED. THE RED "E-STOP" PILOT LIGHT WILL TURN ON WHEN EITHER THE SYSTEM E-STOP CIRCUIT IS ACTUATED, OR EITHER OF THE E-STOP PUSH BUTTONS ARE OPERATED.
2. TO OPERATE THE MACHINE, THE GUARD RESET LIGHT MUST BE OFF. THE GUARD RESET LIGHT WILL TURN OFF WHEN THE THREE (3) PHOTO-EYES ON THE ENTRY SIDE OF THE MACHINE ARE NOT OBSTRUCTED AND THE "GUARD RESET" PUSH BUTTON IS OPERATED. THE "GUARD RESET" PILOT LIGHT WILL TURN ON WHEN ANY OF THE PHOTO-EYES ON THE ENTRY SIDE OF THE MACHINE ARE OBSTRUCTED.
3. IN ANY EMERGENCY PRESS EITHER THE E-STOP OR THE APCU STOP PUSH BUTTONS.
4. TURN THE MANUAL/AUTO SWITCH TO AUTO FOR NORMAL OPERATION.
5. TO STOP THE MACHINE IN A NON-EMERGENCY SITUATION WHILE IT IS TILTING UP, TURN THE MANUAL/AUTO SWITCH TO MANUAL. OTHERWISE THE MACHINE WILL STOP WHEN THE TILT UP PROXIMITY SWITCH IS ACTUATED.
6. TO STOP THE MACHINE WHILE IT IS DUMPING, RELEASE THE UP OR DOWN PUSH BUTTONS. OTHERWISE, THE MACHINE WILL STOP WHEN THE DUMP UP PROXIMITY SWITCH IS ACTUATED.
7. TO STOP THE MACHINE IN A NON-EMERGENCY SITUATION WHILE IT IS AUTOMATICALLY LOWERING, TURN THE MANUAL/AUTO SWITCH TO MANUAL. OTHERWISE, THE MACHINE WILL STOP WHEN THE DUMP DOWN AND TILT DOWN PROXIMITY SWITCHES ARE ACTUATED.

INSTALLATION NOTES:

1. A JUMPER WIRE IS SUPPLIED BETWEEN TERMINALS 4 & 11 (SEE LINE 5 OF SCHEMATIC). REMOVE JUMPER WIRE IF AN ADDITIONAL E-STOP PUSH BUTTON OR CONTACT IS REQUIRED.

8.6 PLC Logic (Third Generation Stand-Alone APCU Only) - PLC (Easy-E4-UC-12RC1)

EDP: Circuit diagram

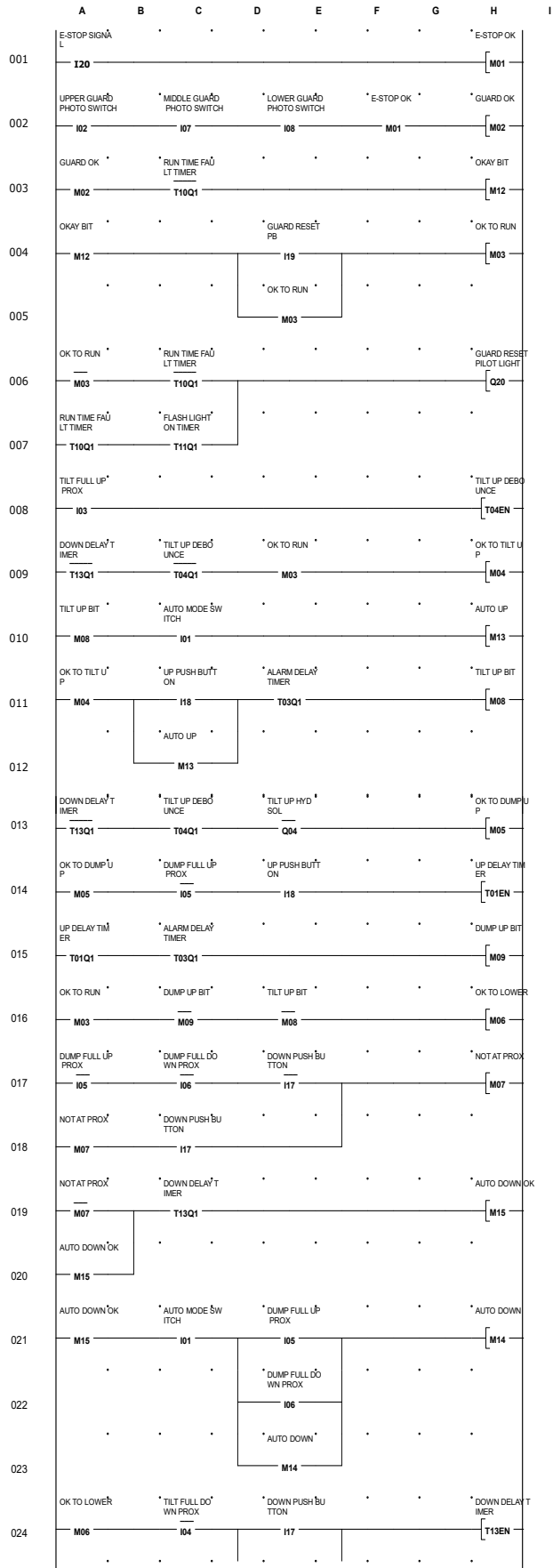

EDP: Circuit diagram

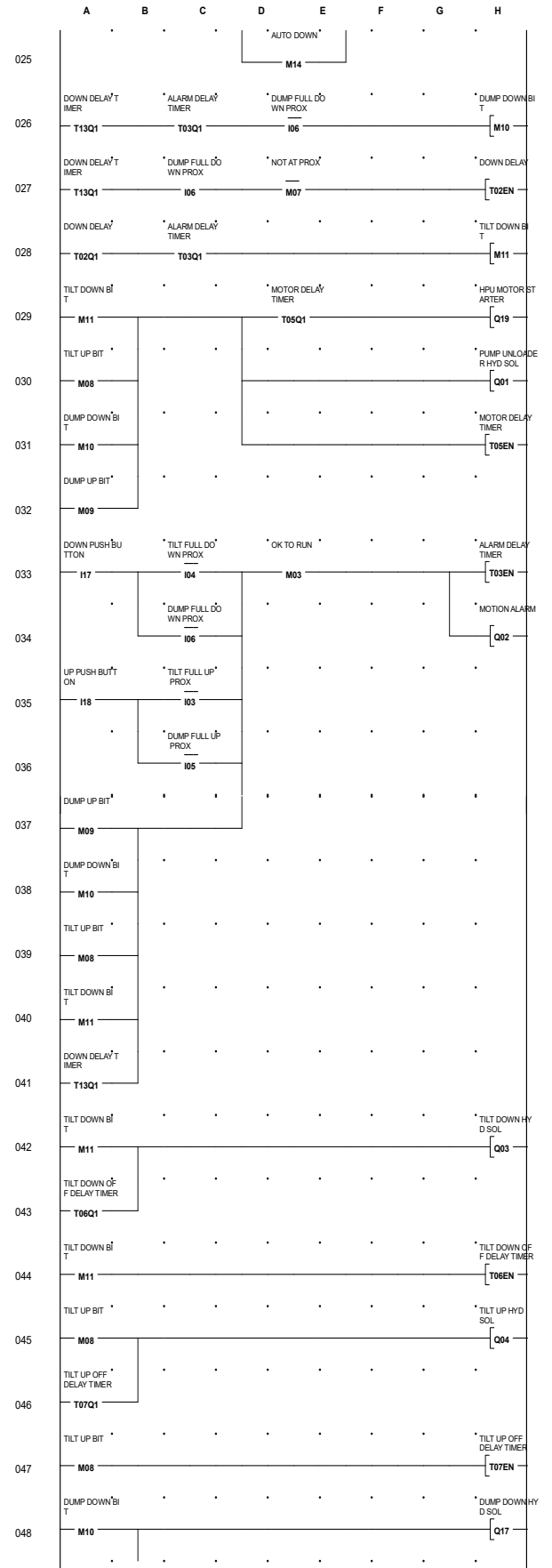

EDP: Circuit diagram

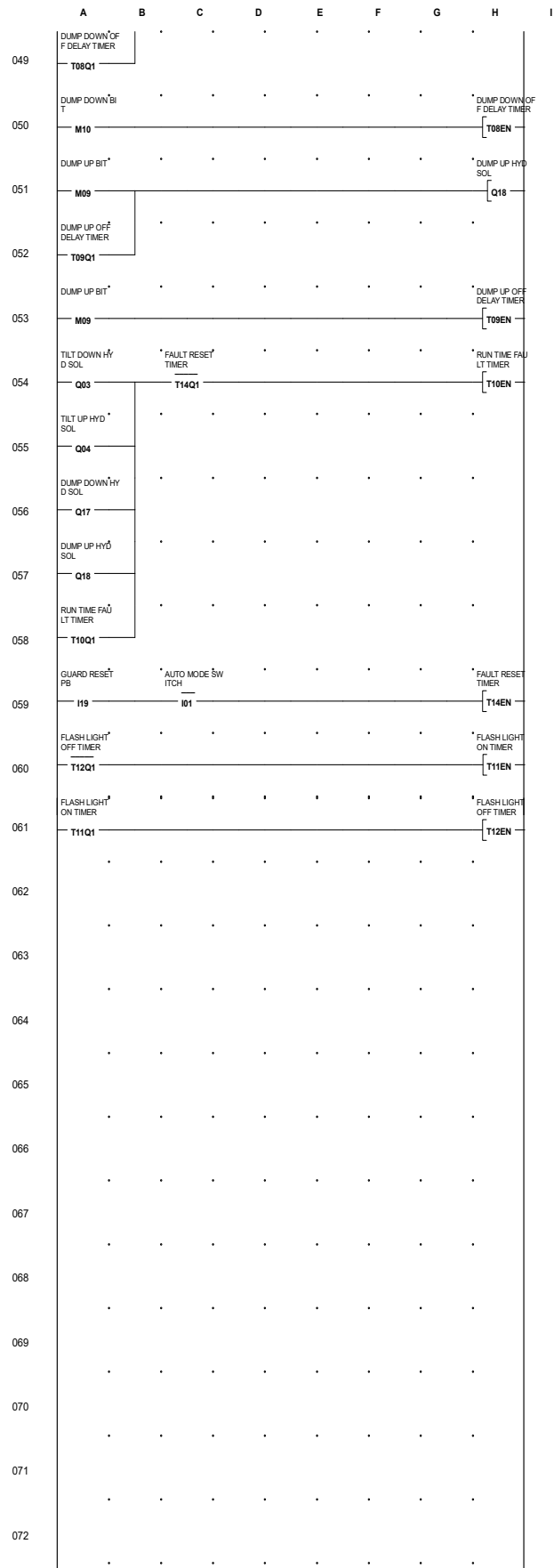

8.7 DC Power Supply Kit (Third Generation Stand-Alone APCU Only)

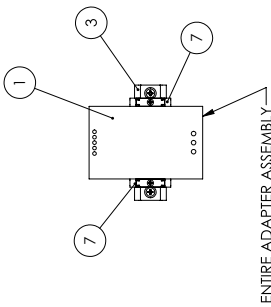
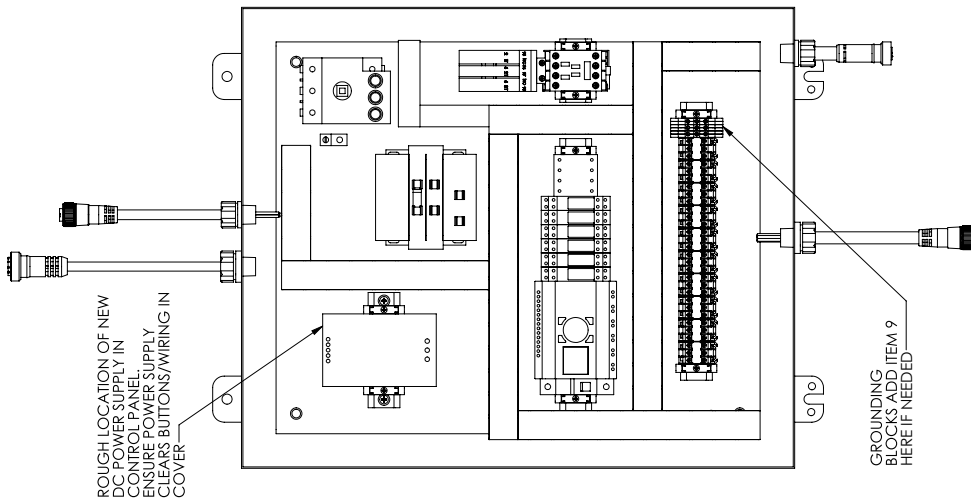

ENTIRE ADAPTER ASSEMBLY

MANUFACTURING NOTE:

- INCLUDE 8 FEET OF EACH:
- BULK 16 GA BLUE WIRE
 - BULK 16 GA WHITE WIRE WITH BLUE STRIPE
 - BULK 14 GA GREEN WIRE WITH YELLOW STRIPE

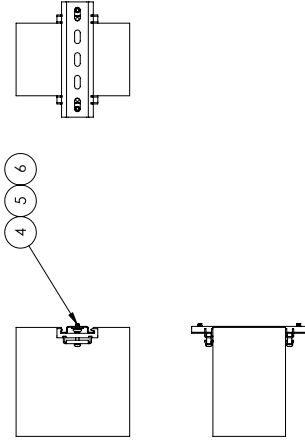

PLEASE FAMILIARIZE YOURSELF WITH THE INSTRUCTION MANUAL INCLUDED WITH THE APCU PRIOR TO PERFORMING EITHER PROCEDURE BELOW.

FOR MACHINES SHIPPED PRIOR TO 7/16/2016

1. ENSURE PANEL IS UNPOWERED.
2. OPEN ELECTRICAL DISCONNECT (IF EQUIPPED) ALLOWING DOOR TO OPEN.
- * 3. REMOVE PANEL FROM APCU AND SET ONTO WORK BENCH.
- * 4. ENSURE WIRES ATTACHED TO QUICK DISCONNECT CABLES ARE NOT BENT OR CUT.
- * 5. MAKE NOTE OF ALL CONNECTIONS AND COMPONENTS.
- * 6. REMOVE ALL COMPONENTRY FROM THE CABINET EXCEPT FOR WIRE DUCTS.
- * 7. <PARA - REMOVE AND DISCARD ORIGINAL DC POWER SUPPLY. PLACE THE FULL RETROFIT KIT INTO THE PANEL ROUGHLY IN THE LOCATION SHOWN IN DRAWING VIEW. THIS MAY VARY SLIGHTLY FROM GENERATION TO GENERATION. CLOSE THE DOOR TO THE PANEL FOR OTHER CONNECTIONS TO THE RETROFIT COMPONENTS. MARK THE LOCATION AND PROCEED TO THE NEXT STEP.
- * 8. REMOVE THE PANEL BACK PLATE FROM THE CONTROL PANEL.
- * 9. DRILL THE BACK PLATE FOR #10-24 SCREWS (0.156" DRILL) TO SECURE DIN RAIL FOR MOUNTING POWER SUPPLY AS SHOWN IN THE VIEW TO THE UPPER LEFT. THERE SHOULD BE ENOUGH ROOM TO MOUNT WITHOUT RELOCATING ANY OF THE WIRE DUCTS. ENSURE ALL METAL FILINGS AND SHAVINGS ARE VACUUMED OFF THE BACKPLATE (FRONT AND BACK) FROM THE DRILL AND TAP OPERATION PERFORMED IN STEP 8.
- * 11. REINSTALL THE BACK PLATE INTO THE PANEL.
- * 12. REINSTALL ALL ELECTRICAL COMPONENTS AND RE-WIRE USING NOTES FROM STEP 4 WITH THE EXCEPTION OF THE DC POWER SUPPLY. USE INCLUDED WIRING DIAGRAM AS REFERENCE.
13. <PARA - INSTALL THE NEW DC POWER SUPPLY AND DIN CLAMPS.
14. THE DC FEED WIRES FROM AC POWER.
15. TO REACH THE NEW POWER SUPPLY, ADDITIONAL BLUE 16 GA AND WHITE 16 GA WIRES WILL BE REQUIRED FOR THE DC POWER SUPPLY WIRES TO GO TO NEW WIRES FOR THE DC POWER SUPPLY. ADDITIONALLY IF THERE WERE NO GROUND WIRE (22) RUN TO THE POWER SUPPLY, A NEW WIRE SHOULD BE RUN (GREEN/YELLOW WIRE INCLUDED). A GROUNDING LUG (ITEM 9 - NOT SHOWN) THAT CAN BE ADDED TO THE LOWER DIN RAIL IN THE PANEL IS ALSO INCLUDED. IN THE EVENT THAT THE PREVIOUS GROUND LUGS ARE ALL UTILIZED, VERIFY YOU HAVE RE-WIRED POWER SUPPLY EXACTLY AS ORIGINAL WAS CONNECTED. COMPARE AND TEST USING ITEM 10 AS REFERENCE.
18. CLOSE DOOR AND CLOSE ELECTRICAL DISCONNECT (IF EQUIPPED).
19. ENSURE POWER IS RESTORED TO INDICATOR LIGHTS (IF EQUIPPED).
20. OPERATE UNIT TO TEST.

INSTRUCTIONS FOR MACHINES SHIPPED AFTER 7/16/2016

1. ENSURE PANEL IS UNPOWERED.
2. OPEN ELECTRICAL DISCONNECT ALLOWING DOOR TO OPEN
3. LOCATE DC POWER SUPPLY AND ENSURE WIRES ARE LABELED BEFORE REMOVING.
4. REMOVE WIRES FROM TERMINALS ON DC POWER SUPPLY.
5. LOOSEN DIN RAIL CLAMP AND REMOVE AS NEEDED.
6. REMOVE DC POWER SUPPLY FROM DIN RAIL.
7. REMOVE NEW DC POWER SUPPLY ON DIN RAIL IN ADAPTER KIT.
8. INSTALL NEW DC POWER SUPPLY ON EXISTING PANEL DIN RAIL.
9. REPLACE DIN RAIL CLAMP.
10. RE-WIRE POWER SUPPLY EXACTLY AS ORIGINAL WAS CONNECTED.
11. CLOSE DOOR AND CLOSE ELECTRICAL DISCONNECT.
12. OPERATE UNIT TO TEST.
13. DISCARD ITEMS 3-7 BELOW IN BILL OF MATERIAL (AND ANY WIRE INCLUDED WITH KIT) AS THESE ARE ONLY NEEDED TO ADAPT OLDER APCU MACHINES.

ITEM NO.	REF	QTY.	U/M	DESCRIPTION	PART NO.
10	REF			EL WIRING DIAG 208/230/460 AC XFMR	3064525T
9	EA			EL TERM GND ELMEX ET 6	5908253T
8					
7	EA			EL DIN RAIL CLAMP IDEC BNLS (OR EQUIV)	2166181
6	EA			BK-HA WSHR LCK-SPT STL #10	2340482
5	EA			HA WSHR FLAT STL #10 SAE	10085865
4	EA			HA SCREW MCMCAR 92525A549	10085873
3	EA			EL DIN RAIL (MUST BE STEEL)	10085864
2					
1	EA			EL PWR SPLY 24V .10A (240W) DIN RAIL	10082002

CUSTOMER NOTE : STEPS 3, 4, 5, 8, 11, AND 12 ARE THE OFFICIAL SOUTHWORTH RECOMMENDED WAY OF PERFORMING THIS OPERATION. IT MAY BE POSSIBLE TO LEAVE THE CONTROL PANEL MOUNTED TO THE APCU AND LEAVE THE ELECTRICAL COMPONENTS IN THE PANEL IF EXTREME CAUTION IS TAKEN DURING THE DRILLING AND TAPPING OPERATION.

- THIS WOULD INCLUDE:
 - WRAPPING THE COMPONENTS AND WIRING CAREFULLY TO PREVENT METAL SHAVINGS FROM ENTERING OR BEING TRAPPED
 - COATING DRILL BITS WITH GREASE TO CATCH AS MANY FILINGS AS POSSIBLE
 - VACUUMING OUT THE PANEL AFTER DRILLING AND TAPPING
 - USING TAPE TO REMOVE ANY FILINGS/SHAVINGS LEFT BEHIND

9 HYDRAULICS

9.1 Hydraulic Schematic

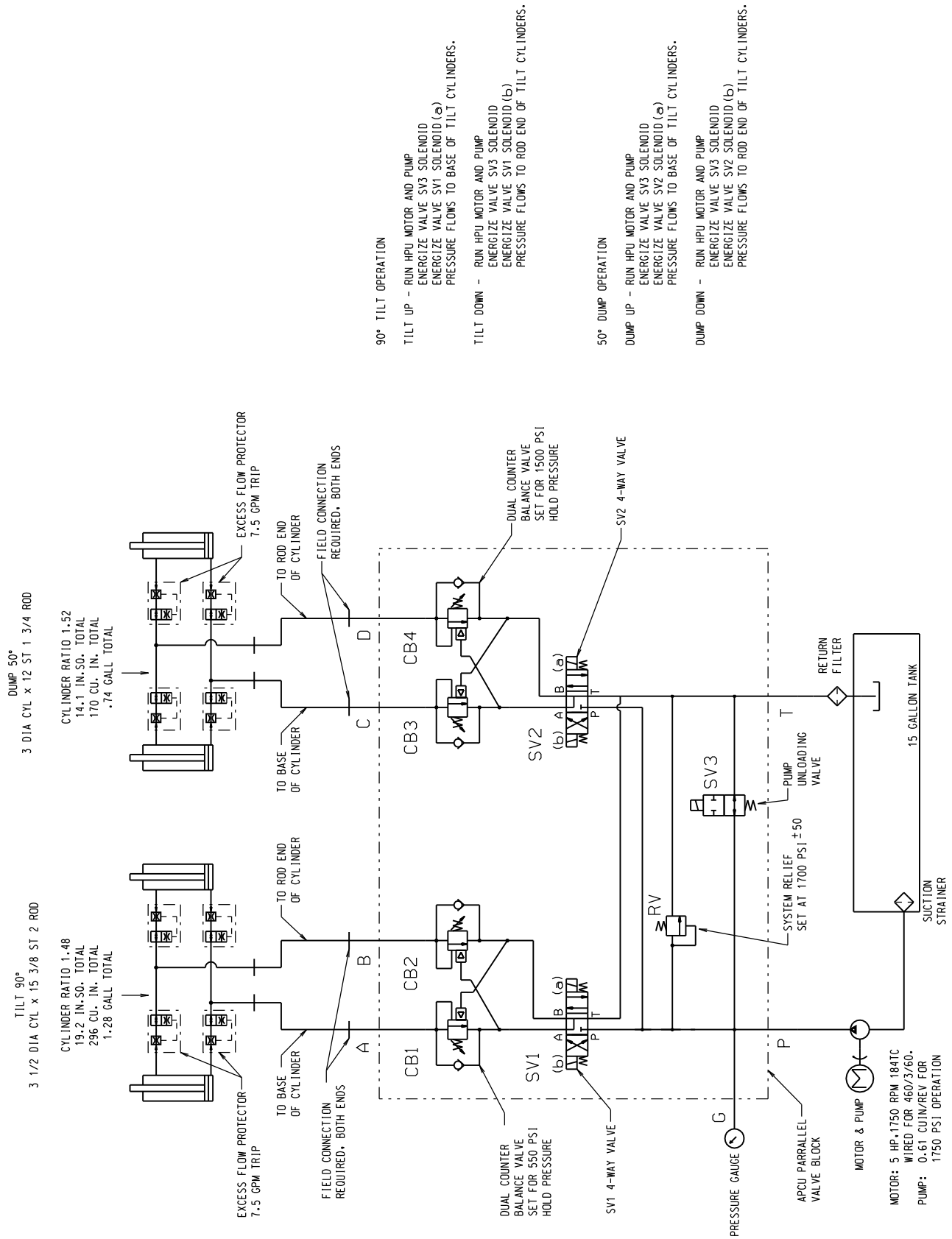

9.2 Hydraulic Power Unit

MOTOR: 5HP, 1750 RPM 208/230 - 460V / 3 / 60, 184TC wired for 460. 6.7 Full Load Amps

PUMP: Parker gear pump: 0.61 CU IN / Rev with pump adapter and flex coupling for 1750 PSI operation.

RESERVOIR: 15 gallon with suction strainer, fluid level sight gauge, return filter and drip pan.

VALVE MANIFOLD: Parker 2-station parallel manifold with system relief valve, dual counterbalance valves and pump unloading valve.

PRESSURE GAUGE: 0 - 2,000 PSI

HYDRAULIC FLUID: Conoco AW32 or equivalent

CAUTION

See Torque Requirements for Hydraulic Hose Connections section when making or tightening any hydraulic hose connections.

Debris in the hydraulic system can damage the hydraulic pump. Make sure tank and lines are clear of debris before operating the machine.

NOTES:

- Fill tank to the proper level indicated on tank level / temperature gauge before operating system. Be sure not to overfill and thoroughly clean any spills.
- For long term storage make sure all exposed ports and fittings are capped or plugged.

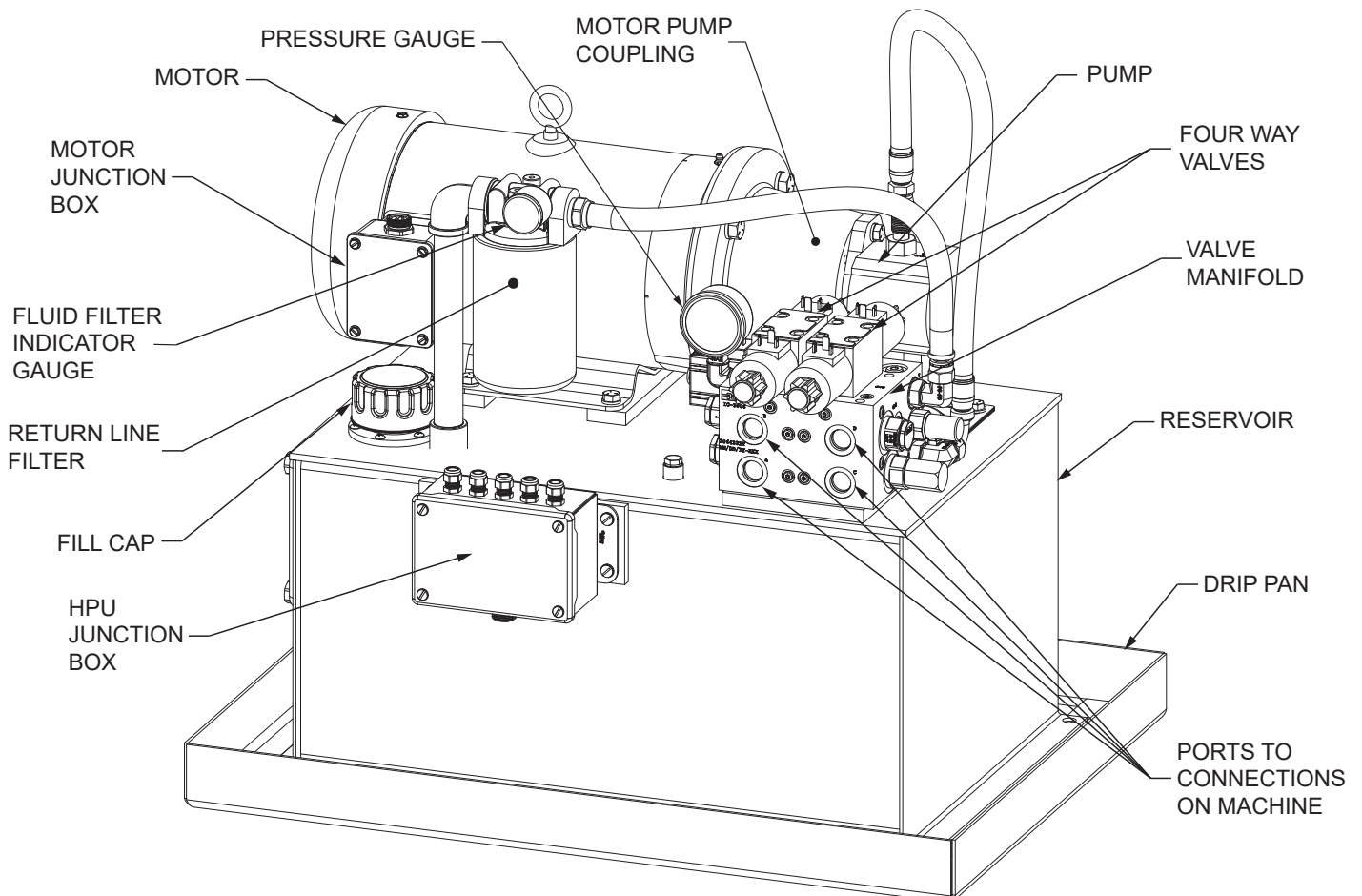

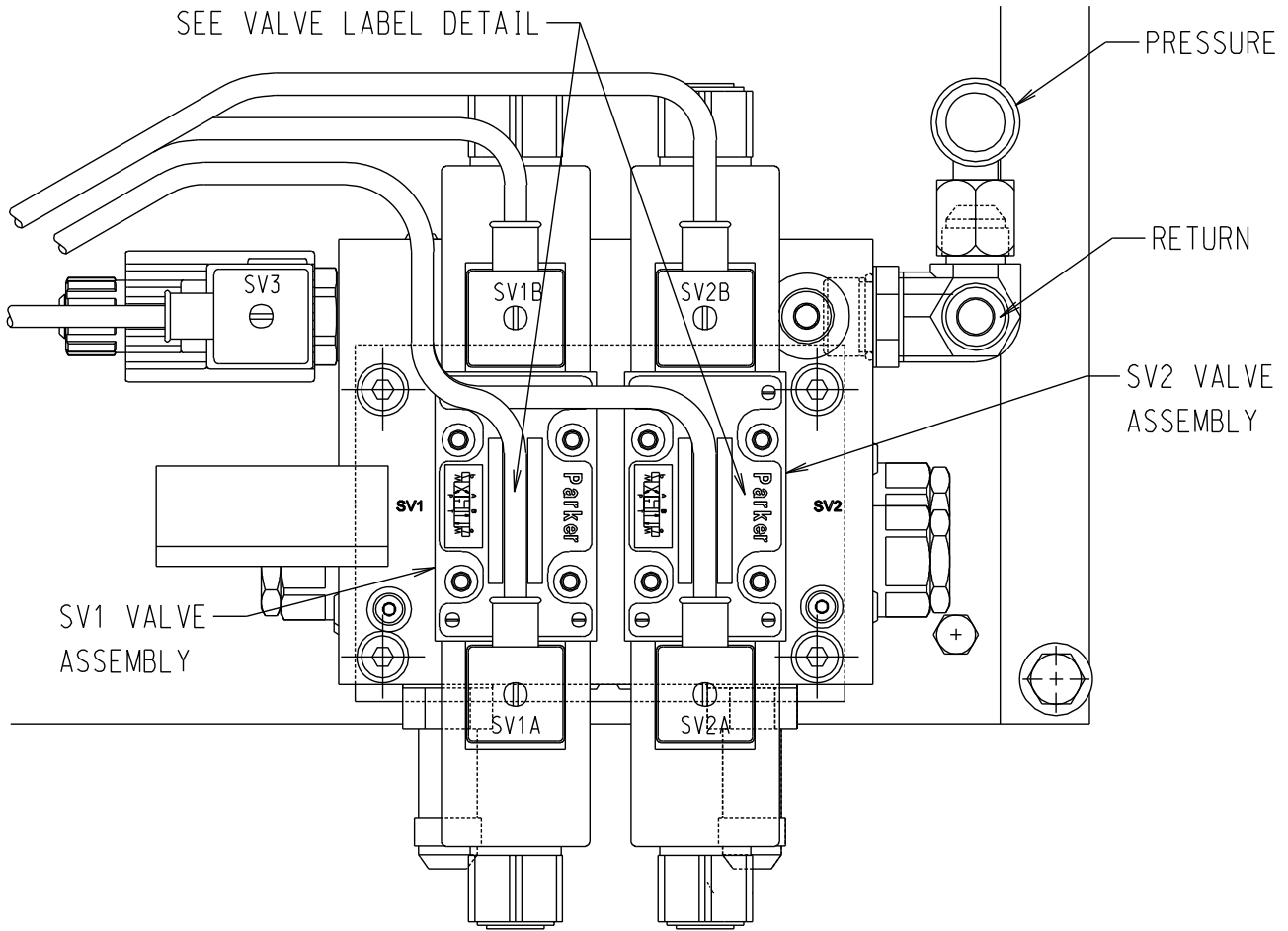

VALVE ASSEMBLY DETAIL

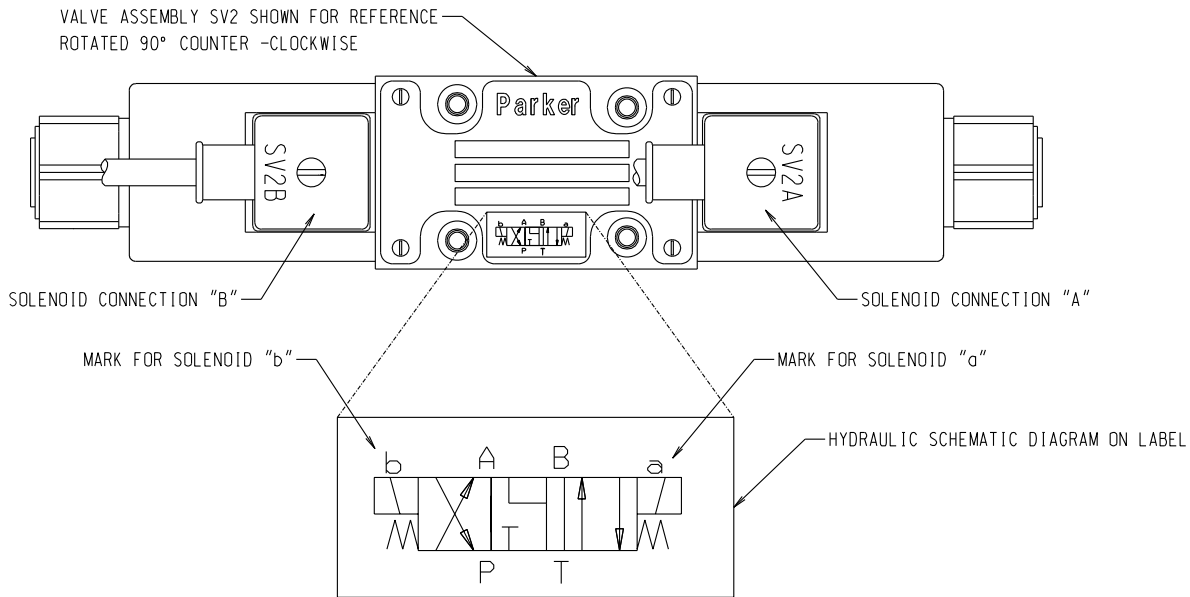

- VALVE REF: 1) USE LABEL ON TOP OF VALVE TO VERIFY LOCATION OF SOLENOIDS "a" AND "b".
 2) SOLENOID "a" IS LOCATED ON SAME END AS SHOWN ON SCHEMATIC AND SHOULD HAVE ELECTRICAL CONNECTIONS MARKED "A" FOR BOTH VALVES.
 3) SOLENOID "b" IS LOCATED ON SAME END AS SHOWN ON SCHEMATIC AND SHOULD HAVE ELECTRICAL CONNECTIONS MARKED "B" FOR BOTH VALVES.
 4) USE TOP OF VALVE STACK STAMPINGS TO VERIFY THE VALVE ASSEMBLIES MARKED "SV1" AND "SV2" AND MAKE ELECTRICAL CONNECTIONS AS SHOWN.

10 OPTIONAL SUPPORT STANDS USE PROCEDURE

The APCU Support stands must not be used for hydraulic, electrical, or mechanical maintenance.

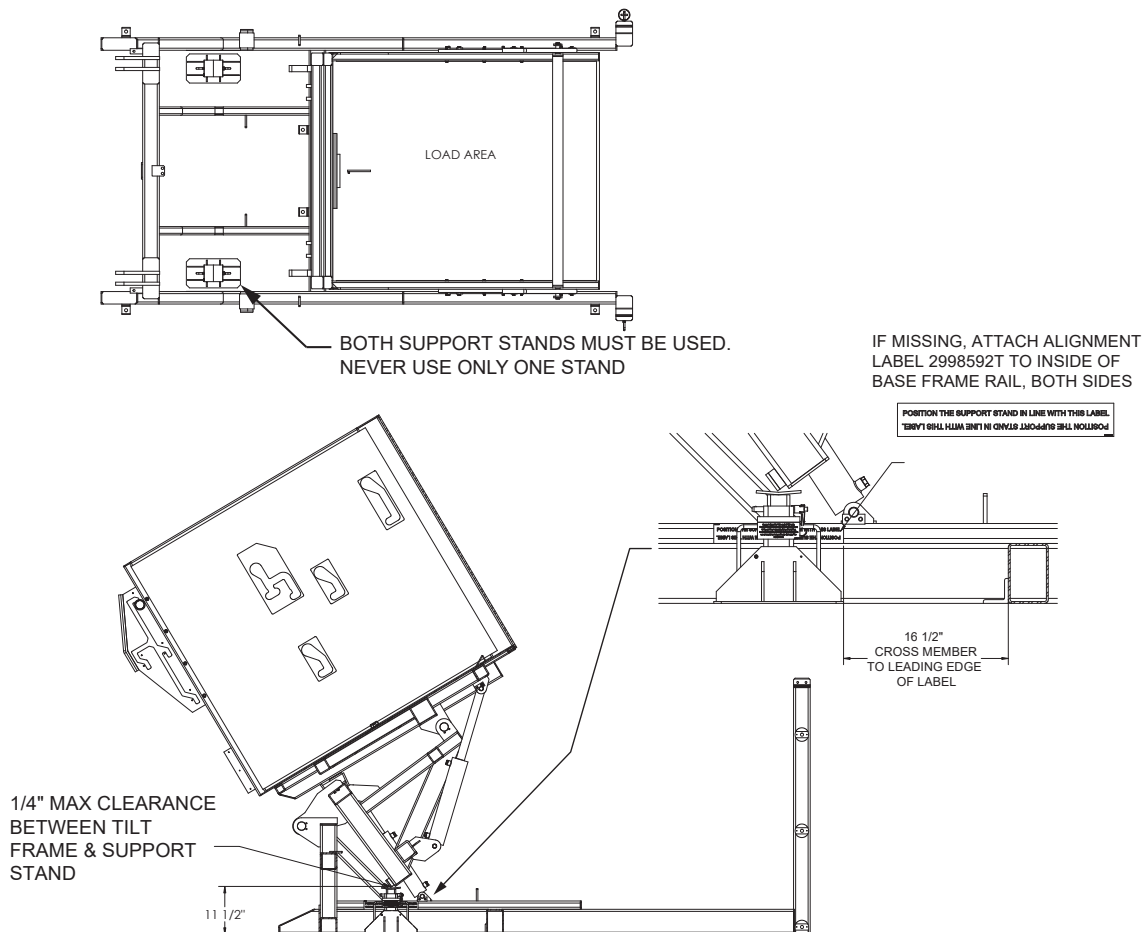

NOTICE

Read and understand this Optional Support Stand Use Procedure before using the support stands. Failure to follow the use procedure may result in damage to the machine.

1. Using the control push-button, raise the load enclosure to the Tilt up (PRS1) position.
2. Turn off and lock out the main disconnect switch on the control panel.

NOTICE

If equipped with a Grace voltage indicator, ensure that no lights are illuminated.

3. Set the support stands at the lowest extension height pin position.

NOTICE

Both support stands must be used. Never have only one stand under the tilt frame for support.

4. Position each support stand in the load area as shown. Location is indicated by alignment label on inside of base frame.
5. After personnel are clear from load area, remove lock and turn the main disconnect switch to the ON position.
6. Turn the MANUAL/AUTO selector switch to the MANUAL Position and press and hold the down button to lower tilt frame onto the support stands.

NOTICE

⋮
⋮ **If the frame begins to contact the stands the machine must be stopped. Do not**
⋮ **overpower the frame onto the stands or the machine may be damaged. See Floor**
⋮ **Conditions & Leveling Information.**
⋮

7. Turn off and lock out the main disconnect switch on the control panel. It is now safe to enter the load area.

To return the machine to regular service:

8. Remove lock and turn on the main disconnect switch on the control panel.
9. Raise the tilt frame to the Tilt up (PRS1) position.
10. Turn off and lock out the main disconnect switch on the control panel.
11. Remove the support stands from the load area.
12. After personnel are clear of the load area, remove the lock and turn the main disconnect switch on.
13. Lower the load enclosure to the fully lowered position.

11 WARRANTY & CONTACT INFORMATION

Southworth Products Corp. warrants this product to be free from defects in material or workmanship for the duration of the warranty period. Warranty periods vary and begin on the date of shipment. For specific warranty information, contact Southworth Products with the machine's serial number.

Any claim for breach of this warranty must be received in writing by Southworth within the warranty period. Warranties shall not cover failure or defective operation, caused by misuse, misapplication, negligence or accident, exceeding recommended capacities, or any alteration or repair of the item purchased which has not been authorized by Southworth. Except as set forth herein, Southworth makes no other warranties, express or implied, including THE WARRANTIES OF MERCHANTABILITY AND OF FITNESS FOR A PARTICULAR PURPOSE, all of which ARE HEREBY EXCLUDED.

Southworth meets the labeling requirements of California's Proposition 65. Southworth makes no warranty or representation with respect to the compliance of any product with other State or local safety or product standard codes and any failure to comply with such codes shall not be considered a defect of material or workmanship under this warranty. Southworth shall not be liable for any direct or consequential damages arising out of such non-compliance.

Southworth's obligations under any warranty or for any other damages which may arise under any sale, agreement, or contract, are limited to the replacement or repair of defective components at its factory or another location at Southworth's discretion. This is buyer's sole remedy under any such warranty, sale, agreement, or contract. Southworth will not be liable for consequential, incidental, exemplary, or punitive damages of any kind resulting from a breach of any warranty that it has provided or for breach of any term of any sale, agreement, or contract. Any warranty may be altered only in writing by Southworth.

All commodities, software, or technology purchased from Southworth are subject to the export and re-export control laws and regulations of the United States, including but not limited to the Export Administration Regulations ("EAR") and Department of the Treasury Office of Foreign Asset Controls ("OFAC") Regulations. Southworth expects all distributors and customers to comply with these laws and regulations. Without limiting the foregoing, the distributor/customer cannot, without proper authorization from the applicable United States Government Agency, export, re-export, or transfer any commodity, software, or technology purchased from Southworth, either directly or indirectly, to any entity, country, or national of any country in breach of such laws and regulations. Furthermore, Southworth expects that the distributor/customer shall indemnify and hold harmless Southworth from and against any claim, proceeding, action, fine, loss, cost and damages arising out of or relating to any noncompliance with export control regulations by distributor/customer, and distributor/customer are expected to compensate Southworth for all losses and expenses resulting thereof, unless such noncompliance was clearly not caused by fault of the distributor/customer.

SOUTHWORTH PRODUCTS CORP.
P.O. Box 1380, Portland, ME 04104-1380
800-743-1000 | 207-878-0700 | Fax: 207-797-4734
www.SouthworthProducts.com

SOUTHWORTH

To view a copy of the Terms and Conditions of Sale, go to: <https://SouthworthProducts.com>
(Find in Resource Library pull down menu)

12.1 Installation of Generation Two, Lockheed Martin Integrated Replacement

NOTICE

⋮
⋮
⋮
⋮
⋮
⋮
⋮
⋮

The schematics, wiring, and connections for Generation Two replacements do not match the schematics, wiring, and connections shown in this manual. The control panel, operator controls, and wiring were provided by Lockheed Martin. Refer to the original Lockheed Martin documentation for this information.

Several components from the existing machine must be saved and installed on the new machine. These items are:

- The existing control panel, mounting weldment, and associated hardware.
- Power wiring into the control panel.
- Operator controller and associated wiring.
- Wiring to the larger system from the control panel to the multi-port connector on the rear of the machine.

12.1.1 Uninstalling the Existing Generation Two APPS Machine

1. Lock-out/tag-out the main power supply.
2. Before disconnecting the existing wiring, label all connected wires and ports at the control panel. Each wire is numbered according to the corresponding plug.
3. Disconnect the cord sets between the control panel and hydraulic power unit, between the control panel and the multi-port connector, and between control panel and the stack light. These cord sets do not need to be saved; they will be replaced with new, provided cord sets.
4. Disconnect the external system cord from port one of the multi-port connector (if present). The cord must be saved to be reconnected to the new machine.
5. If the operator controller is attached to the machine, remove, and save it, and all associated wiring for use with the new machine.



6. Disconnect the powering wiring from the control panel. All existing power wiring will be reused to reconnect the control panel.

7. Remove the control panel and mounting weldment. The control panel, weldment, and associated hardware is to be reused on the new machine.



8. Disconnect the existing (2) emergency stops. The e-stops and associated wiring are to be reused on the new machine.
9. Disconnect the hydraulic hoses from HPU and machine. Uninstall the HPU. The existing HPU will be replaced with the new HPU provided with the new machine.
10. Uninstall the existing machine and remove from the area.

12.1.2 Installing the Replacement Machine

1. Remove or cut the existing anchor bolts flush with the floor.

NOTICE

It is important the existing anchor bolts do not interfere with the position of the new machine. The existing anchor bolts are not to be reused to anchor the new machine.

2. Position the new machine, as necessary. There should be 36 inches between the control panel and any adjacent machines or equipment. The outside edge of the tilt hinge should be approximately 11 inches from the inside face of the conveyor guard and the front lip of the load enclosure should be parallel with the conveyor. The guard must be not taller than 28 inches from the floor.

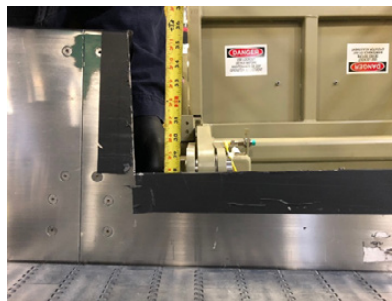

3. Level and anchor the machine. See the **Floor Conditions & Leveling Information and Lagging & Shimming Information** sections.



4. Remove all the red shipping brackets.
5. Position the hydraulic power unit, as necessary.
6. Connect the hydraulic hoses. Connect port A of the valve stack to port A on the rear of the machine, connect port B of the valve stack to port B on the rear of the machine. The valve manifold and machine connection points are labeled accordingly.

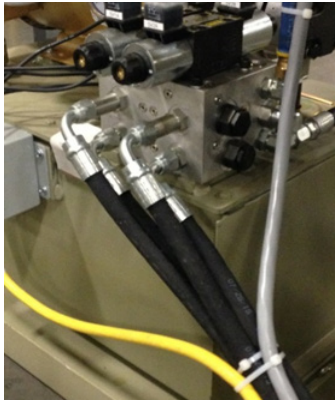

⚠ CAUTION

See **Torque Requirements for Hydraulic Hose Connections** section when making or tightening any hydraulic hose connections.

Ensure the hydraulic hoses are connected correctly. Incorrectly connecting the hoses could lead to damage to the machine.

7. Install the stack light/audio alarm. The required cord should be connected to the stack light; do not damage the cord while installing.
8. Install the original control panel on the side panels using the existing mounting weldment and hardware.



9. Replace the existing receptacle for the HPU motor with the provided receptacle. The new receptacle should be connected to the new HPU motor cord. Ensure the existing wiring matches the motor starter. Discard the old receptacle.
10. If applicable, connect cord from the external system to port one on the multi-port connector. Remove and discard the jumper plug. (The multi-port connector may look different than the image shown below. The port references are the same but the multi-port connectors themselves look different and are mounted differently. See alternative illustrated on the next page.)

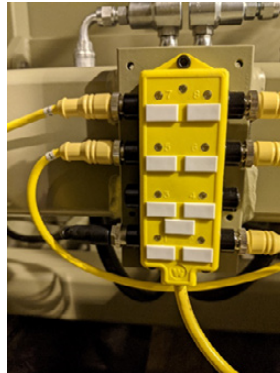

11. Connect the HPU motor cord, HPU valve power cord, stack light power cord, and cord from the multi-port connector into the control panel.

12.1.3 Testing and Adjustments

1. Ensure all photo eyes operate correctly.
2. Ensure all proximity switches are correctly adjusted. See the **Adjusting Proximity Sensors** section.
3. Ensure all emergency stops operate correctly.
4. Clean area of all debris, spills, and tools.
5. Ensure all hydraulic fittings are tight and there are no leaks.

12.1.4 Multi-Port Connections

Our typical multi-port connector is an outward facing unit with side mount connectors. Our alternative multi-port connector is an inward facing unit with front mount connectors. See images below for mounting layouts. The ports are identical.

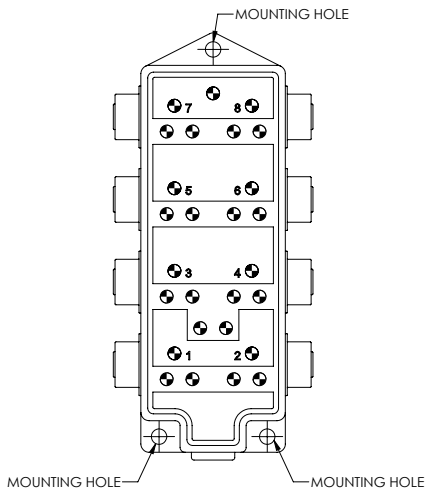
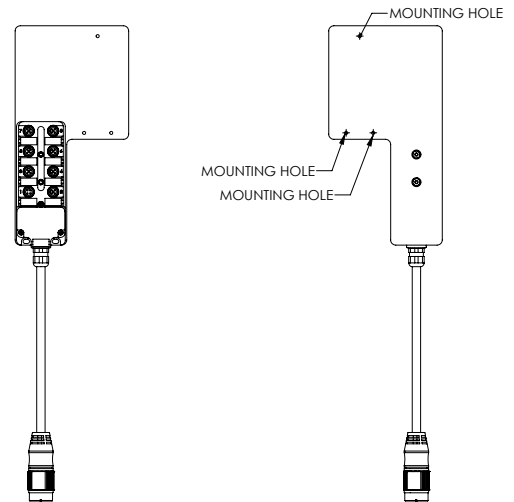
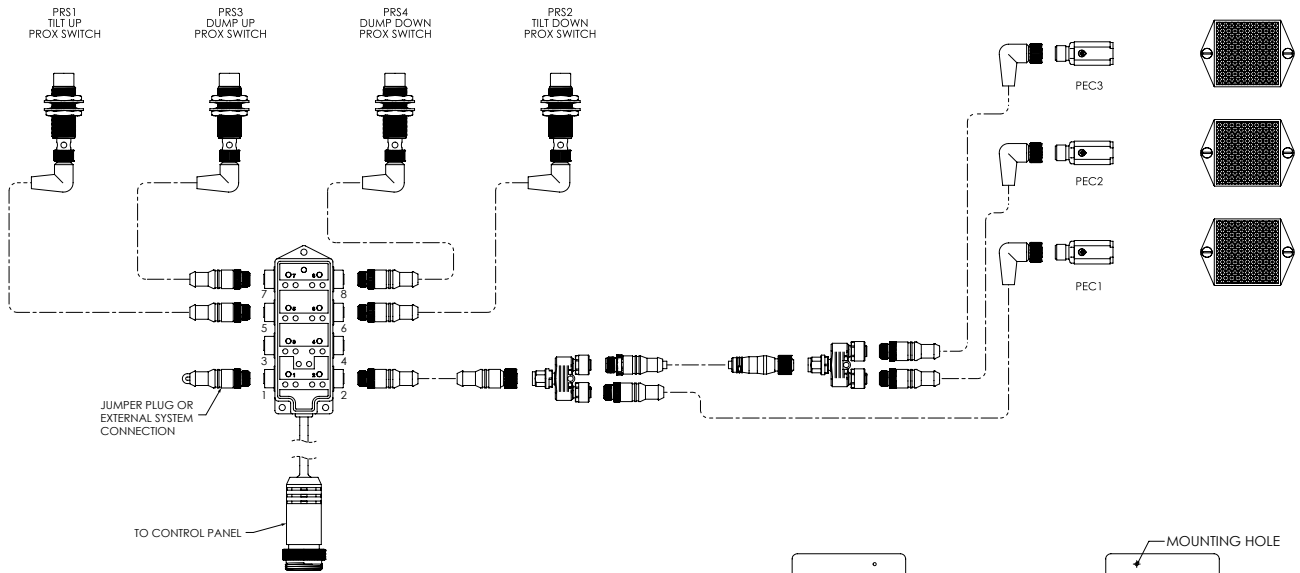

Typical multi-port connector

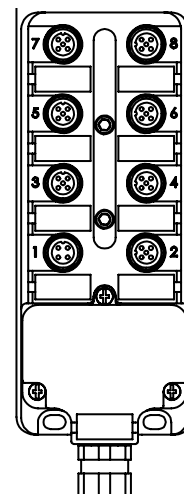

Alternative multi-port connector

12.1.5 Sensor Arrangement

