

OWNER'S MANUAL

Roll-On™ Level Loader

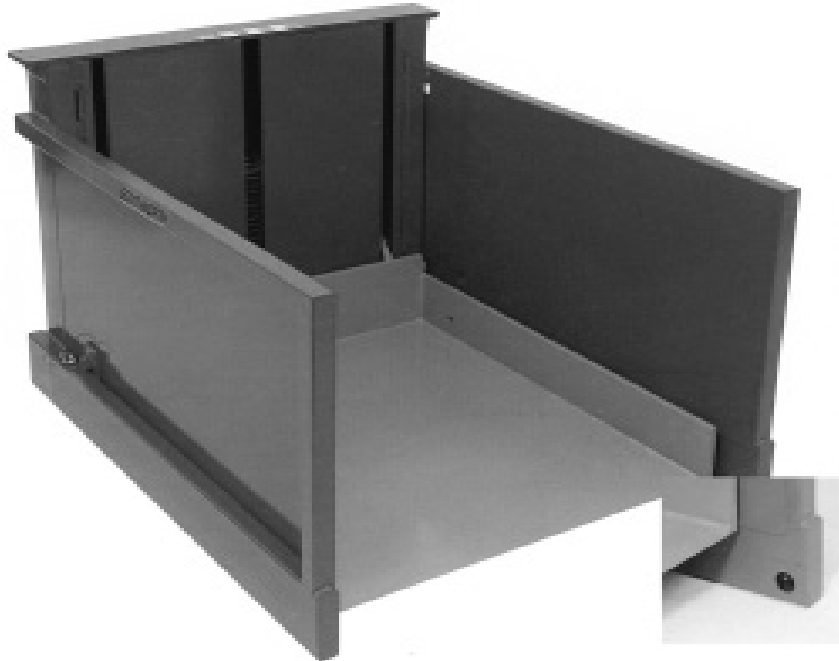

Model # _____

Serial # _____

Placed in Service _____

SOUTHWORTH

Southworth Products Corp

P.O. Box 1380 Portland, Maine 04104-1380

Phone: 207-878-0700 Fax: 207-797-4734

July 2015

Please note: This manual was current at the time of printing.
To obtain the latest, most updated version, please contact Southworth's Customer Service Department or go to our website: www.SouthworthProducts.com,
under Parts & Service
you will find a complete list of current
owner's manuals to print.

CONTENTS

- INTRODUCTION4
- RESPONSIBILITY OF OWNERS AND USERS5
- SAFETY6
- INSTALLATION INSTRUCTIONS6
 - Preparation6
 - Positioning the Unit.....6
 - Electrical Connections8
 - Testing8
 - Hydraulic Oil Specifications9
- OPERATING INSTRUCTIONS.....10
 - Safety Alert Symbol and Signal Words10
 - Labels and Precautionary Markings11
 - Safety Instructions12
 - Loading the Unit.....12
 - Raising the Platform13
 - Lowering the Platform.....14
- MAINTENANCE AND TROUBLESHOOTING14
 - Hazards14
 - Routine Periodic Maintenance15
 - Maintenance for Units with Flush Mount Turntable.....16
 - Removing the Turntable Top.....18
 - Inspecting and Lubricating the Turntable.....18
 - Troubleshooting Check List19
 - Repacking the Cylinder.....21
 - Adjusting the Chain Tension21
- ORDERING REPLACEMENT PARTS.....21
- WARRANTY Back of Manual

LIST OF FIGURES

- Fig. 1 Safety Labels7
- Fig. 2 Pinch Points8
- Fig. 3 Load the Unit Correctly9
- Fig. 4. Labels and Precautionary Markings11
- Fig. 5. Electrical Diagram.....12
- Fig. 6. Hydraulic Diagram13
- Fig. 7. Parts Identification — Front view16
- Fig. 8. Parts Identification — Rear view.....17
- Fig. 9. Hydraulic Pump17
- Fig. 10. Down Valve18

- Table 1 Hydraulic Oil Specifications9

INTRODUCTION

The Roll-On Level Loader is designed to allow faster, safer, and easier pallet loading and unloading. Pallets may be loaded or unloaded in a single step, using a fork truck, or hand pallet truck. Using a pushbutton or footswitch control, the operator can position boxes or containers at a convenient working height. This allows workers to load or unload without bending or stretching.

The unit includes a photo eye toe guard feature. A photo eye is positioned near the front of the unit. If the operator's toes block this photo eye, the unit stops immediately.

This manual contains instructions on the safe and proper installation, use, and maintenance of a Roll-On Level Loader. Please be sure that this manual is available to anyone who uses or services the Roll-On unit. Be sure that everyone who uses the Roll-On unit has read this manual.

Roll-On units may be used in a wide variety of industrial settings. The instructions included in this manual are not necessarily all-inclusive, because Southworth cannot anticipate all conceivable or unique situations.

In the interest of safety, please read this whole manual carefully. Please understand the material in the manual before you install, use, or service the Roll-On Level Loader. If you have any questions about the instructions in this manual, please contact your dealer or Southworth Products Corp.

Southworth's product warranty is shown on the rear cover of this manual. This instruction manual is **not intended to be or to create any other warranty, express or implied, including any implied warranty of merchantability or fitness for a particular purpose, all of which are hereby expressly excluded.** As set forth more specifically in the product warranty, Southworth's obligation under that warranty is **limited** to the repair or replacement of defective components, which shall be the buyer's **sole remedy**, and Southworth shall not be liable for any loss, injury, or damage to persons or property, nor for any direct, indirect, or consequential damage of any kind resulting from the Roll-On Level Loader.

Responsibility of Owners and Users

Inspection and Maintenance

The device shall be inspected and maintained in proper working order in accordance with Southworth's owner's manual.

Removal from Service

Any device not in safe operating condition such as, but not limited to, excessive leakage, missing rollers, pins, or fasteners, any bent or cracked structural members, cut or frayed electric, hydraulic, or pneumatic lines, damaged or malfunctioning controls or safety devices, etc. shall be removed from service until it is repaired to the original manufacturer's standards.

Deflection

It is the responsibility of the user/purchaser to advise the manufacturer where deflection may be critical to the application.

Repairs

All repairs shall be made by qualified personnel in conformance with Southworth's instructions.

Operators

Only trained personnel and authorized personnel shall be permitted to operate the lift.

Before Operation

Before using the device, the operator shall have:

- Read and/or had explained, and understood, the manufacturer's operating instructions and safety rules.
- Inspected the device for proper operation and condition. Any suspect item shall be carefully examined and a determination made by a qualified person as to whether it constitutes a hazard. All items not in conformance with Southworth's specification shall be corrected before further use of the equipment.

During Operation

The device shall only be used in accordance with this owner's manual.

- Do not overload.
- Ensure that all safety devices are operational and in place.

Modifications or Alterations

Modifications or alterations to any Southworth industrial positioning equipment shall be made only with written permission from Southworth.

SAFETY

The safety of all persons installing, using, servicing, or working near the Roll-On unit is of paramount concern to Southworth. The Roll-On unit is a powerful machine with moving parts, and is CAPABLE OF CAUSING PERSONAL INJURY IF PROPER PRECAUTIONS ARE NOT TAKEN.

Therefore, throughout this manual, Southworth has identified certain hazards which may occur in the use of the Roll-On unit, and provided appropriate INSTRUCTIONS or PRECAUTIONS which should be taken to avoid these hazards. In some cases, Southworth has also pointed out the CONSEQUENCES which may occur if Southworth's instructions or precautions are not followed. Southworth uses the following system of identifying the severity of the hazards associated with its products:

PLEASE READ AND FOLLOW THIS INSTRUCTION MANUAL, INCLUDING ALL SAFETY INSTRUCTIONS AND PRECAUTIONS, CAREFULLY AND COMPLETELY.



Immediate hazard which will result in severe personal injury or death.



Hazard or unsafe practice which could result in severe personal injury or death.



Hazard or unsafe practice which could result in minor personal injury or property damage.

INSTALLATION INSTRUCTIONS

Preparation

1. Before you start to install the unit, check for local codes and ordinances which may apply. It is your responsibility to obtain any necessary permits.
2. Read all of these installation instructions carefully. Be sure to read and understand all of the warnings.
3. The unit should be placed indoors, or protected from the weather.



Protect the unit from rain or moisture. If the electrical parts in the power unit get wet, workers may be hurt by electrical shock. The electrical parts may fail if they are wet.



The electric motor can create sparks. Don't install the unit in an area where flammable gases may be present.

4. You will need these tools to install the unit:
 - A crane or lift truck that can lift the unit safely. If you plan to lag the unit in place, you will need these tools:
 - Shims and lag bolts.
 - A masonry drill and bit to drill the holes for the lag bolts.
 - Wrenches to fit the lag bolts
 - Grouting material to fill any spaces under the frame of the machine.

Positioning the Unit

1. Remove the shipping material. Unbolt the lag screws at the lag angles on the corners. (If you plan to bolt the unit in place, leave the lag angles attached to the frame of the unit. Otherwise, unbolt and remove the lag angles.)
2. On the front of this manual, write down the model number, serial number, and date the unit is placed in service. You can find the model number and serial number on the name plate.

3. During shipping, the platform of the unit is raised 5-1/2", and this platform is supported on two pins. This allows a space under the platform. When you want to move the unit, put a pallet jack under the platform and lift the unit. This is the best way of moving the unit.

CAUTION

Always raise the platform and insert the pins before you move the unit. If you try to move the unit in another way, the frame may be bent. Be sure to remove the pins before you operate the unit. If you do not do this, the unit may be damaged. Once the unit has power, raise the platform just a bit to take the load off of the pins, then remove the pins.

4. The unit has an 8' (243 cm) power cord. Choose a location where the cord can reach an outlet easily, without stretching the cord tightly.

5. Move the unit into position, supporting the platform of the unit. Place the unit on a firm, level surface.

CAUTION

If you place the unit on a surface which is not firm or level, the unit may shift as it operates. You may be hurt, or the unit or load may be damaged.

6. The unit may be operated without bolting the frame to the floor. However, the mounting arrangement is more secure if you use lag screws. Bolt the unit to the floor using four lag bolts. These should run through the lag angles at the corners of the base frame. Insert and tighten the lag bolts to secure the unit. Grout under the base rails to prevent vibration and distortion of the base frame.

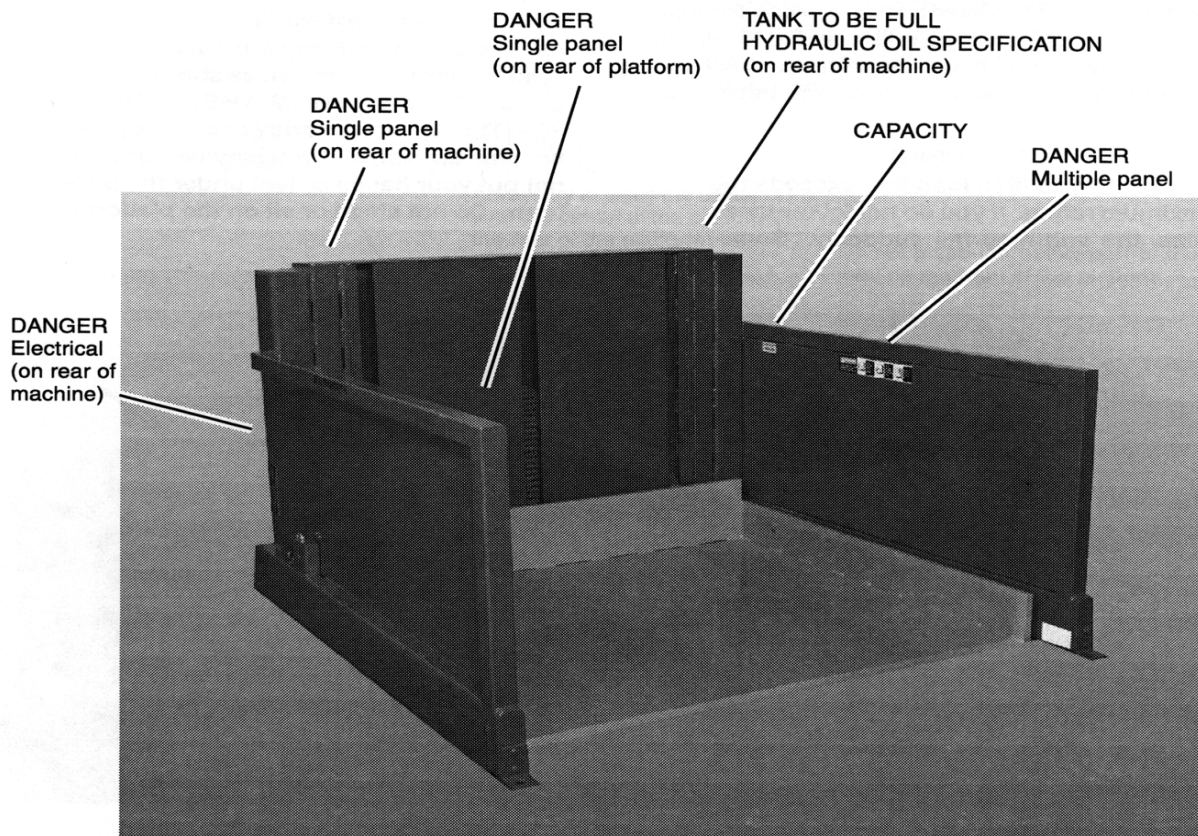

Fig. 1 Safety Labels

Roll-On™ Level Loader

Electrical Connections



The unit uses a power supply of 115 volts AC. This voltage can kill you. Don't work with the electrical parts unless you are a qualified electrician.

1. The unit is supplied with a power cord which is 8' long (243 cm). You must provide a two-prong outlet within this distance from the unit. The circuit should be provided with a dedicated 20 amp circuit breaker or fuse servicing no other electrical devices.



To avoid fire danger, be sure to provide a circuit breaker or fuse.

2. The standard unit has a foot switch assembly. Some units have an optional controller which uses pushbuttons. On either type of unit, the control box is attached by an 8' cable (243 cm). Position the control box in a convenient location near the unit.
3. Check the level of the hydraulic fluid in the tank. In order to check the level, lower the unit completely and unplug the power cord.

Remove the rear cover on the unit. When the unit is fully lowered, the oil should be 1/2" to 3/4" (13 to 19 mm) below the top of the tank. Add oil as necessary.

Testing

1. Clear the area around the unit. Remove any loose wires, lumber, or other materials which might get in the way of the unit as it raises or lowers.
2. Warn others to stay away from the unit. Operate the unit through its full range of travel. The unit should rise smoothly with a quiet humming sound, and lower smoothly and quietly. Raise and lower the unit a few times to check the lifting action.



As the platform moves up and down, "pinch points" are created at the places shown in Fig. 2. If you are standing too close to the unit when it is moving, your arm or leg may be caught in the moving parts, and you may be hurt. Stay away from the pinch points when the unit is moving.

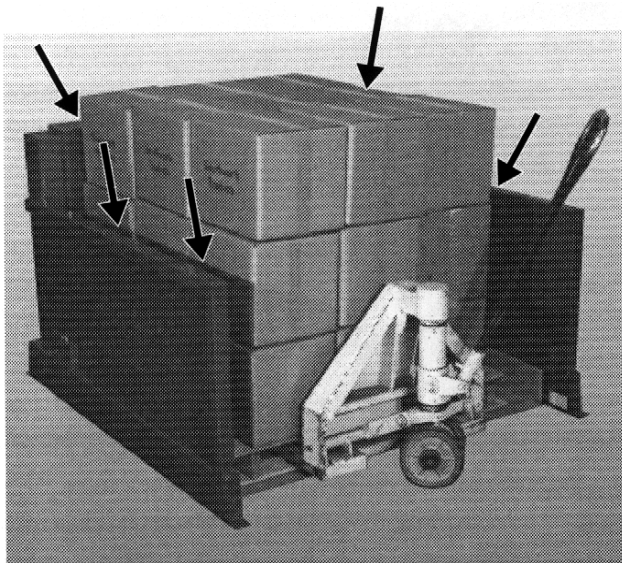

Fig. 2a Pinch points when loading

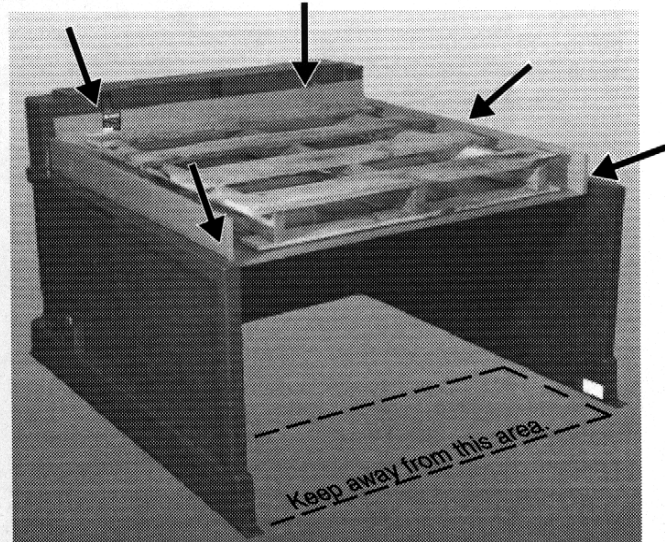

Fig. 2b Pinch points when raising or lowering

3. Test the unit with the rated load. If the unit does not rise, and you hear a loud squealing noise, the pressure relief valve is operating. Contact Southworth for instructions.

⚠ WARNING

Don't continue to use the unit if this happens - the pump will overheat very quickly, and may be permanently damaged. Do not try to adjust the relief valve. If you change the setting on the relief valve, you may overwork the unit. This can cause the unit to fail suddenly, and you may be hurt.

4. Clean up any spilled hydraulic fluid. Spilled hydraulic oil is slippery, and may present a fire hazard. If you clean up any spilled fluid, you will be able to tell right away if the unit begins to leak.
5. Figure 1 shows the safety labels on this unit. Check to be sure all of the labels are in place.

Table 1 – Hydraulic Oil Specifications

If the lift will be used at normal ambient temperatures, Southworth supplies the unit with Citgo AW 32 oil. This may be replaced by any other good quality oil with 150 SSU at 100° F and rust and oxidation inhibitors and anti-wear properties.

If the lift will be used at ambient temperatures below 0°F, use aircraft hydraulic oil. Use Type 15 aircraft hydraulic oil.

The following are equivalent to CITGO AW32:

TYPE	MANUFACTURER
DTE 24	EXXON/MOBIL
NUTO H32	EXXON/MOBIL
AMOCO AW32	CHEVRON (AMOCO CO.)

CAUTION!

It is very important to keep the hydraulic oil free of dirt, dust, metal chips, water, and other contamination. Most of the problems with hydraulic systems are caused by contamination in the oil.

If the load is uneven, place the heavy section near the rear of the platform.

Always try to place the center of the load over the center of the platform (24" from the rear of the platform)

Do not place the heavy part of the load on the front of the platform.

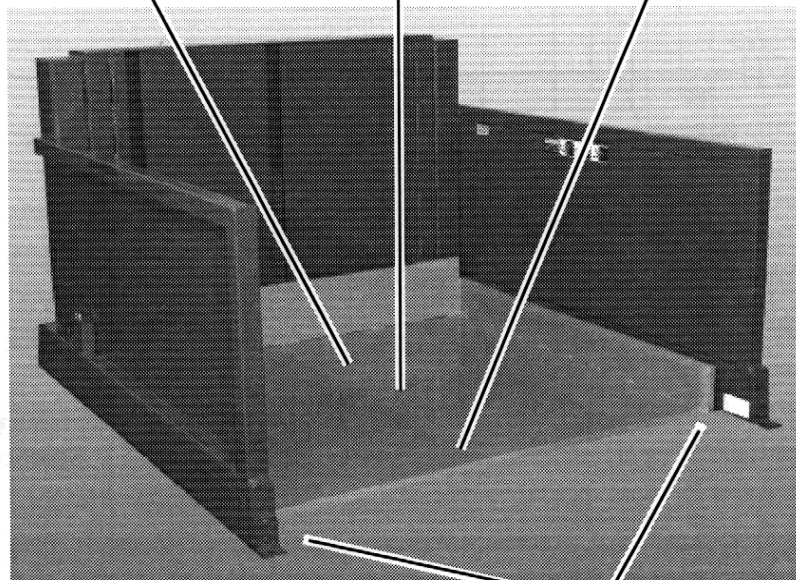

Balance the load side-to-side

Fig. 3 Load the unit correctly

OPERATING INSTRUCTIONS

SAFETY ALERT SYMBOLS AND SIGNAL WORDS

The safety of all persons operating, maintaining, repairing, or in the vicinity of this equipment is of paramount concern. This is a powerful machine with moving parts, and is capable of causing personal injury if proper precautions are not taken. Therefore, throughout this manual, certain hazards have been identified which may occur in the use of the machine, and there are appropriate instructions or precautions which should be taken to avoid these hazards. In some cases, there are consequences which may occur if instructions or precautions are not followed. Below are the symbols and signal words along with their definitions referenced from ANSI Z535.4 - Product Safety Signs and Labels.

Safety Alert Symbols

These are the safety alert symbols. They are used to alert you to potential physical injury hazards. Obey all safety messages that follow this symbol to avoid possible injury or death.



For use with DANGER signal word
(Red Background)



For use with WARNING signal word
(Orange Background)



For use with CAUTION signal word
(Yellow Background)

Signal Words

The meaning of different signal words as defined by ANSI Standard Z535.4 indicates the relative seriousness of the hazardous situation.



(Red Background)

DANGER indicates a hazardous situation which, if not avoided, will result in death or serious injury.



(Orange Background)

WARNING indicates a hazardous situation which, if not avoided, could result in death or serious injury.



(Yellow Background)

CAUTION, used with the safety alert symbol, indicates a hazardous situation which, if not avoided, could result in minor or moderate injury.



(Blue Background)

NOTICE is used to address practices not related to personal injury.



(Green Background)

SAFETY INSTRUCTIONS (or equivalent) signs indicate safety-related instructions or procedures.

Fig. 4 Labels and Precautionary Markings

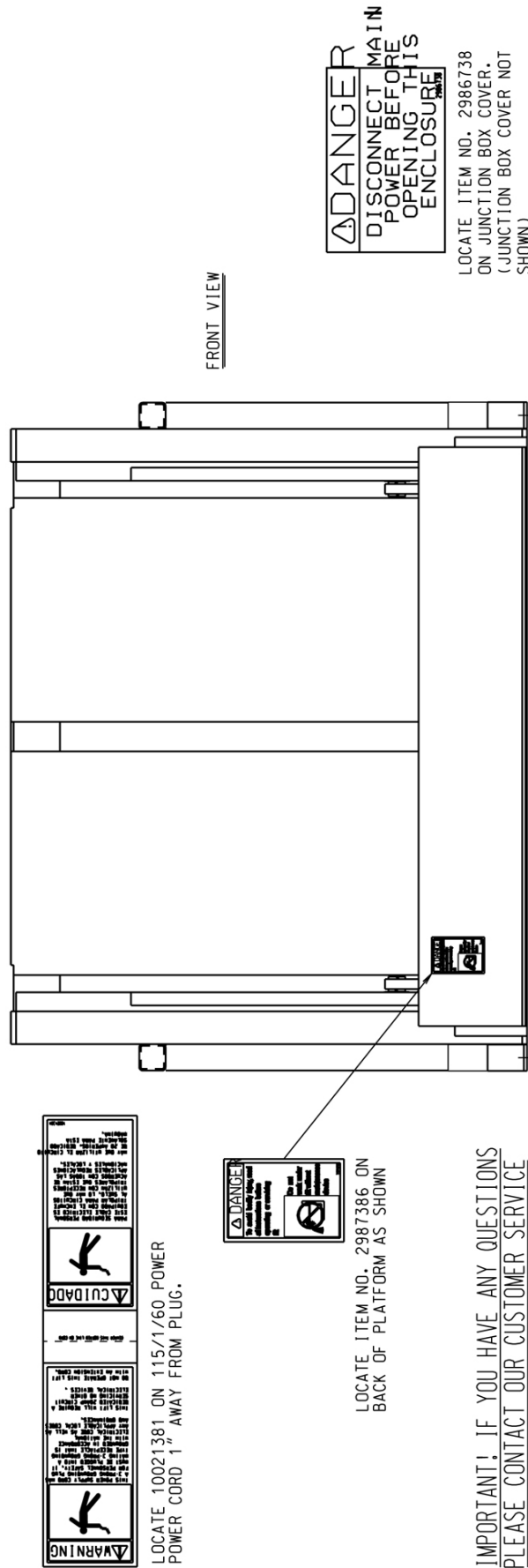

DANGER
DISCONNECT MAIN
POWER BEFORE
OPENING THIS
ENCLOSURE

LOCATE ITEM NO. 2986738
ON JUNCTION BOX COVER.
(JUNCTION BOX COVER NOT
SHOWN)

FRONT VIEW

WARNING **K**

LOCATE 10021381 ON 115/1/60 POWER
POWER CORD 1' AWAY FROM PLUG.

ADVERTENCIA **K**

DANGER

LOCATE ITEM NO. 2987386 ON
BACK OF PLATFORM AS SHOWN

**IMPORTANT! IF YOU HAVE ANY QUESTIONS
PLEASE CONTACT OUR CUSTOMER SERVICE
DEPARTMENT AT 1-800-743-1000**

Roll-On™ Level Loader

OPERATING INSTRUCTIONS

Safety Instructions

⚠ DANGER

The unit uses a power supply of 115 Volts AC. This voltage can kill you. **DON'T WORK WITH THE ELECTRICAL PARTS UNLESS YOU ARE A QUALIFIED ELECTRICIAN!**

⚠ WARNING

As you operate this lift, follow these rules:

- Do not put your hands or feet under the lift platform.
- Do not work under the lift platform without installing the safety pins. (See Fig. 7 and the section on "Maintenance.")
- Do not stand, sit, or ride on the lift.

⚠ WARNING

This unit includes a photo eye toe guard. See Fig. 7. If something blocks the light beam, the unit will stop quickly. The control system will stop the motor and close the down valve, preventing the platform of the unit from moving down. This is designed to prevent the unit from lowering onto the operator's toes. If this safety system is not working correctly, do not operate the unit. Call a maintenance worker right away.

Loading the Unit

1. Before operating the unit, please read and understand all of this section.
2. Be sure that the load weighs no more than the maximum rated for the unit. The maximum rated load is listed on the data plate. Remember that an empty pallet may weigh 40 lbs (18 kg) or more.
3. The load should always be balanced in the side-to-side direction. Whenever possible, place the load in the center of the pallet,

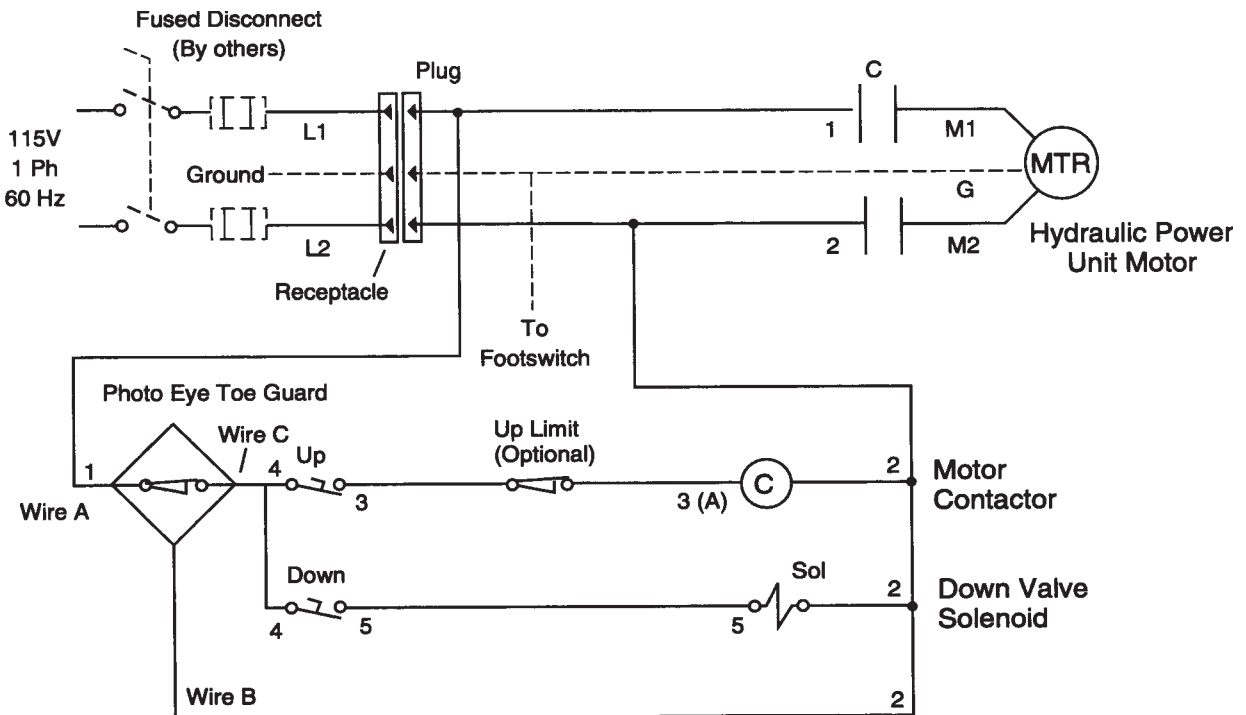

Fig. 5 Electrical Diagram

as shown in Fig. 3. If the load is off-center on the pallet, place the heaviest part of the load near the back of the platform - never near the front!

⚠ WARNING

- Don't try to lift a load that exceeds the maximum rating. If you do not follow these rules, the unit may fail suddenly. Someone may be hurt, or the unit and load may be damaged.

- The unit is designed so it can lift the rated load if the load center is placed over the center of the platform. (The load center should be 24" or 61 cm from the rear of the platform.) If the load is placed "offcenter," near the front of the platform, the unit will not be able to lift the rated load safely. It is also important that the load be centered side-to-side. For these reasons, it is very important to be sure the load is centered in the platform area.

4. Sometimes the unit may be used to lift parts

which can roll. Stack the parts on the pallet so they cannot roll. Be sure that all parts of the load are secure, and will not move as the unit is operated.

Raising the Platform

1. Before raising the platform, be sure all workers are clear of the unit.

⚠ WARNING

As the platform moves up and down, "pinch points" are created as shown in Fig. 2. **STAY AWAY FROM THESE PINCH POINTS!** Part of your body or clothing may become caught, and you may be hurt. Do not put your hands or feet under the platform. Do not stand or sit on the platform.

2. Before lifting, be sure the pallet is pushed up against the back of the unit. Be sure the fork lift or pallet truck is clear of the unit before you begin lifting.

3. Plug in the electrical cord. Be sure the cord cannot become caught in the moving parts as the platform rises.

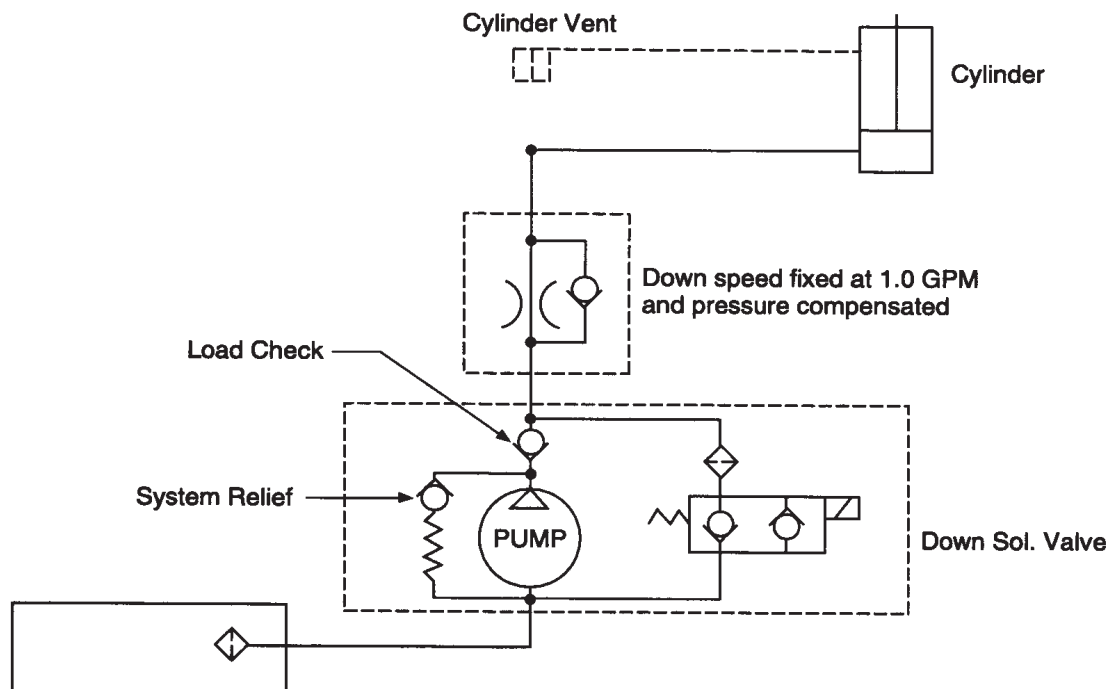

Fig. 6 Hydraulic diagram

Roll-On™ Level Loader

4. Operate the unit. Press and hold the Up button to raise the platform, and Down to lower it. If the unit does not operate right away, unplug the power cord and call a qualified maintenance worker.

⚠️ WARNING

If you hear a squealing noise from the pump, the pressure relief valve is operating. DON'T CONTINUE TO USE THE UNIT! The pump will overheat very quickly, and may be permanently damaged. The relief valve is included to protect the machine operators - DO NOT CHANGE THE SETTING ON THE RELIEF VALVE. If you do change the setting, this may cause a hydraulic part to fail. The platform may drop suddenly. Someone may be hurt, and the unit and load may be damaged. The hydraulic parts in the unit are designed to handle a certain amount of pressure. The relief valve has been included for the protection of all of the workers who use the unit.

Lowering the Platform

1. Press the Down button to lower the platform.
2. Before lowering the platform, be sure all workers are clear of the unit.

⚠️ WARNING

As the platform moves up and down, "pinch points" are created as shown in Fig. 2. STAY AWAY FROM THESE PINCH POINTS! Part of your body or clothing may become caught, and you may be hurt.

3. There is a photoelectric toe guard near the front of this unit. If anything blocks the photoelectric beam, the unit will stop. This is designed to prevent an operator from lowering the platform onto his or her feet.

⚠️ WARNING

Stand back from the unit when raising or lowering the platform. Keep your feet away from the platform when the unit is operating.

MAINTENANCE AND TROUBLESHOOTING

All servicing should be done by qualified personnel. Qualified personnel should be able to read and understand wiring and hydraulic diagrams. They should be able to troubleshoot live electrical circuits safely and in accordance with accepted practice. FOR SAFETY'S SAKE, if in doubt, please contact your distributor or Southworth Products Corp Customer Service Department at (207) 878-0700 or (800) 743-1000. Before servicing the unit, please read and understand all of this section and the section entitled "Operating Instructions."

Hazards

There are several hazards you should be aware of as you service the unit:

⚠️ DANGER

The unit uses a power supply of 115 Volts AC. This voltage can kill you. DON'T WORK ON THE ELECTRICAL PARTS UNLESS YOU ARE A QUALIFIED ELECTRICIAN!

⚠️ WARNING

- **As the unit moves up and down, "pinch points" are formed as shown in Fig. 2. KEEP HANDS, FEET AND LOOSE CLOTHING AWAY FROM THESE PINCH POINTS. If your hand or arm or a part of your clothing is caught, you may be hurt.**

- **Before performing any maintenance on the unit, lower the platform completely. Failure to do so could result in severe personal injury.**

- **You should not have to do any maintenance work with the platform raised. All normal maintenance can be done with the platform lowered. However, if you ever need to work under the platform, you must be careful to do this safely. Raise the platform until you can insert the safety pins on each side. The pins are shown in Fig. 7. Finally, unplug the**

power cord. **DO NOT WORK UNDER THE PLATFORM UNTIL YOU HAVE INSERTED THE PINS.** If you fail to do this, the platform may drop suddenly. You may be hurt.

- The relief valve has been included for the protection of all of the workers who use the unit. **DON'T CHANGE THE RELIEF SETTING!** If the relief valve does not open when it should, the unit may fail. Someone may be hurt, and the unit and load may be damaged.

- If the hydraulic fluid is released under high pressure, it can cause personal injury. Before you open any part of the hydraulic system, **BE SURE TO RELEASE THE HYDRAULIC PRESSURE.** You can do this by lowering the platform all the way down.

- The warning labels have been included for the safety of the operator. If the labels are worn or missing, or have been painted over, **REPLACE THEM** before releasing the lift for operation. Fig. 1 shows the safety markings on this unit.

Routine Periodic Maintenance

Every month:

- Remove the plate on the rear of the unit and check the mechanical parts. Inspect the leaf-type chain which lifts the platform. Check for signs of wear. If the machine is operated in a very dusty environment, you may have to wipe off the dust.
- Check the bolts which anchor the ends of the chain. The chain should be tight, and each bolt should be locked in place.
- Check the level and appearance of the hydraulic fluid. In order to check the level, lower the unit completely and unplug the power cord. Remove the rear cover on the unit. Remove the red plastic vent plug on top of the hydraulic

tank, and use a dipstick to check the oil level. When the platform is fully lowered, the oil should be about 1/2" to 3/4" inch below the top of the tank. Add oil if necessary. Change the oil if it has darkened, or feels gritty or sticky.



It is important to use hydraulic fluid with the correct grade and properties. See the hydraulic oil specification in Table 1 of this manual.

Every six months or 500 hours of operation, whichever comes first:

- Lubricate the lifting chain lightly with spray lube or SAE 30 mineral oil.
- Lubricate the bushing inside the sheave or pulley which supports the upper part of the chain.
- Apply a light coat of grease to the vertical guides for the rollers on the rear of the unit.
- Check all of the hydraulic fittings and hoses, and tighten the connections if necessary. Sometimes the fittings can be worked loose by the vibrations from the power unit.



If a hydraulic fitting becomes loose, or if a hydraulic hose breaks, the hydraulic fluid may escape from the system under pressure. If the platform is raised when this happens, it can drop quickly. Someone may be hurt, or the unit or load may be damaged. To avoid this problem, inspect all of the hydraulic hoses and fittings regularly, and replace them if they are worn or damaged.

- The clear plastic vent line and the cylinder rod should be free of hydraulic fluid. If you find much fluid in either place, the cylinder seals may be leaking. (It is also possible the tank may be over-filled.) If the worn parts must be replaced, see the section on "Repacking the Cylinder."

Roll-On™ Level Loader

- Lower the platform and disassemble the down valve as shown in Fig. 10. Blow the valve plunger clean with compressed air. Reassemble the valve and reinstall it.
- Drain and discard the hydraulic fluid. The suction filter is in the tank, at the point where the suction line runs out to the pump. Unscrew the hydraulic line, then remove the filter. Blow the filter clean with compressed air. Reinstall the filter in the tank and reassemble the hydraulic line.
- Refill the tank with new hydraulic fluid.



If you continue to use fluid after it has “worn out,” the moving parts in the system will wear more quickly.

- Be sure all of the warning labels are in position and legible. See Fig. 1. THE WARNING LABELS ARE INTENDED TO PROTECT YOUR WORKERS. If the labels are missing, or if they have been painted over, replace them.

Maintenance for Units with Flush Mount Turntable

NOTE: It is normal to see some wear on the plate under the turntable. After a short “break-in” period usually 100 to 200 revolutions, a work hardened wear strip will develop, and further wear should be minimal.

Every week, make a general walk-around inspection. Remove any dirt and debris from the turntable top. Clear the gap between the table and the turntable. (An air hose may be used.)

If excessive force is used to rotate the turntable, this may be caused by a lack of lubrication, contaminated bearings, or dirt. To correct the problem, remove the turntable and inspect the mechanism. Clean and lubricate the parts as described in the following sections.

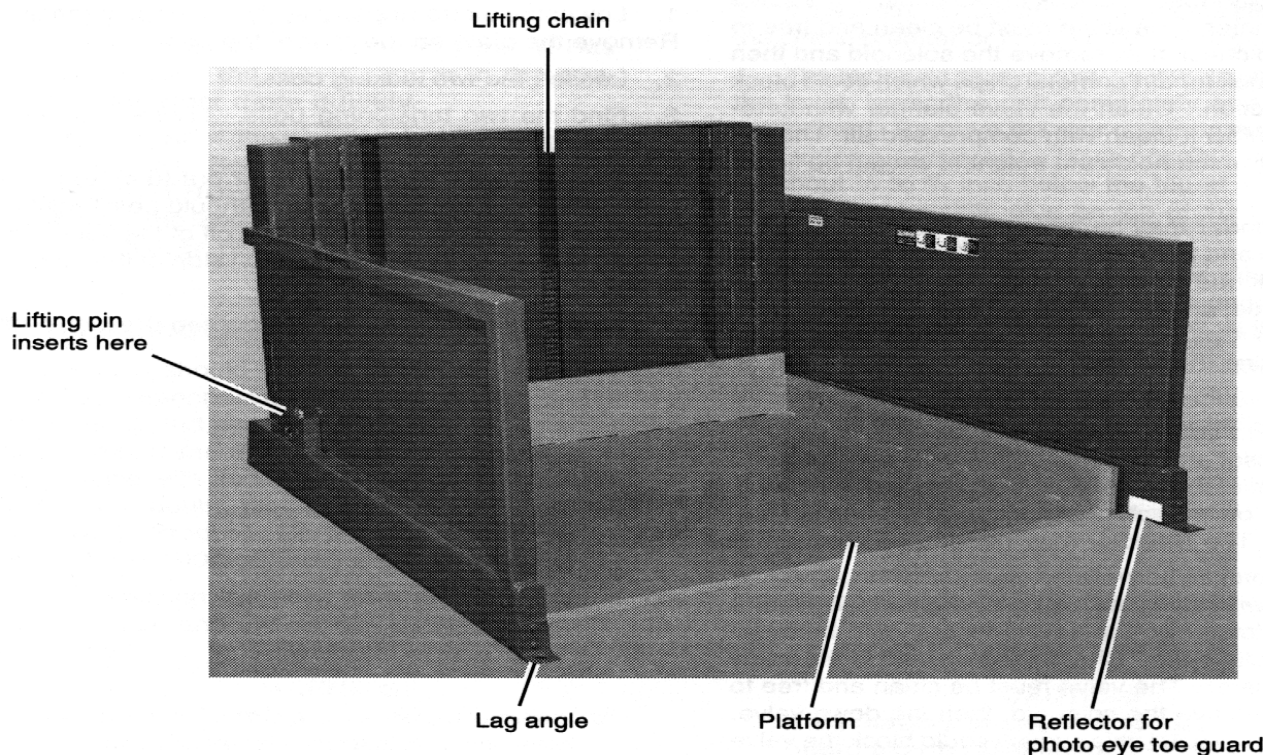

Fig. 7 Parts identification - Front view

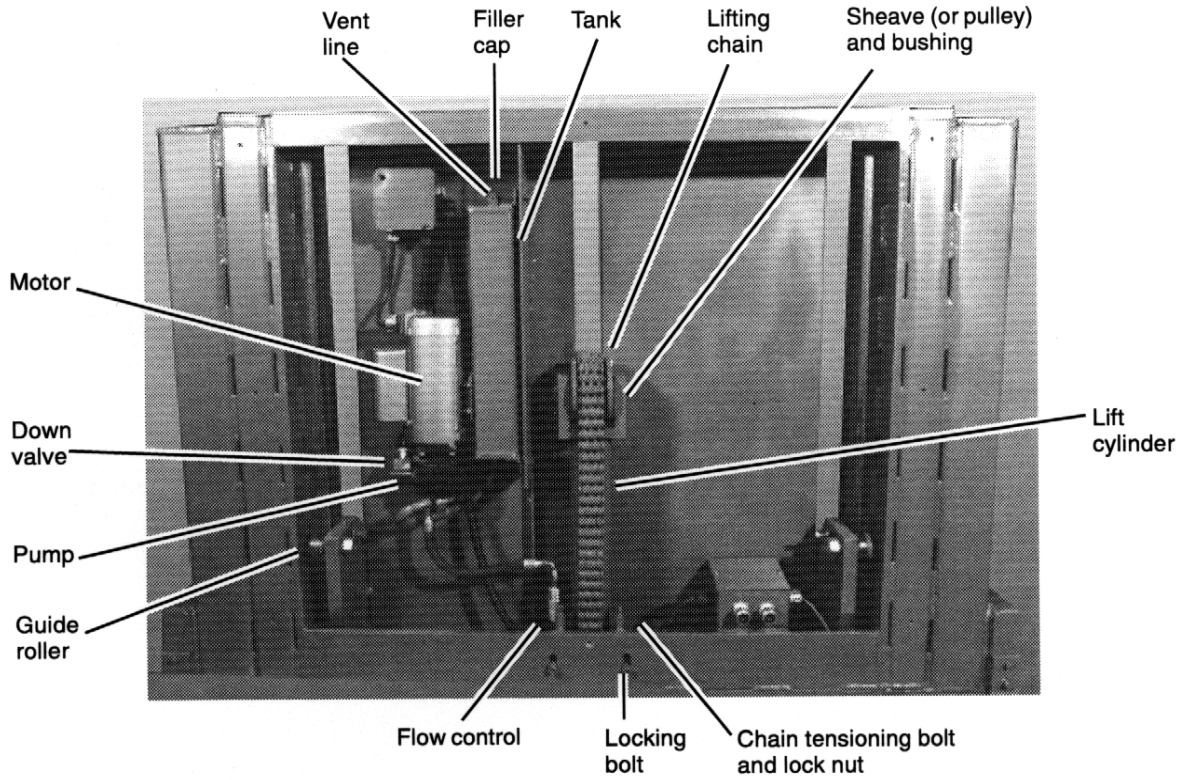
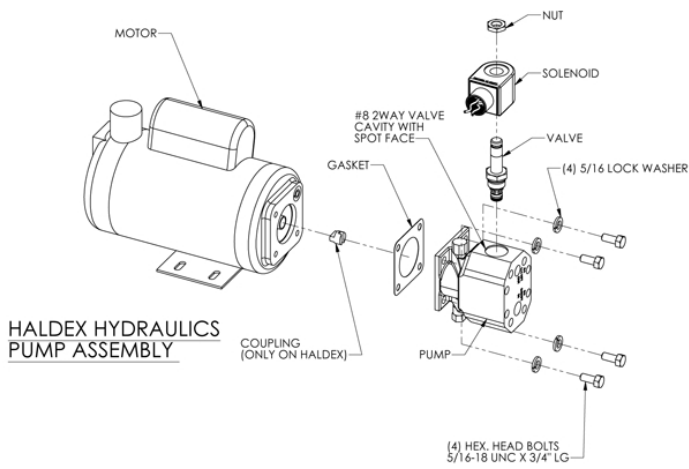

Fig. 8 Parts identification - Rear view



HALDEX HYDRAULICS PUMP ASSEMBLY

Pre 8/22/2012

Fig. 9 Pump

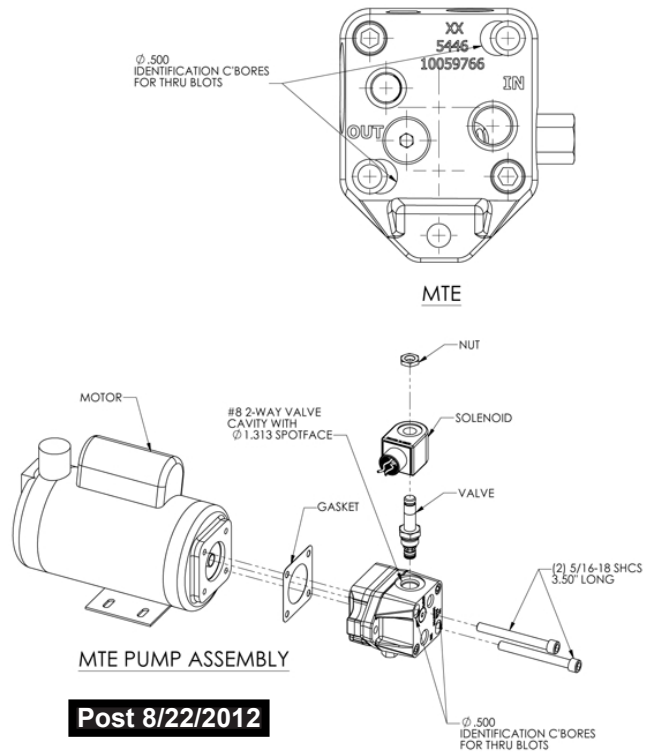

MTE PUMP ASSEMBLY

Post 8/22/2012

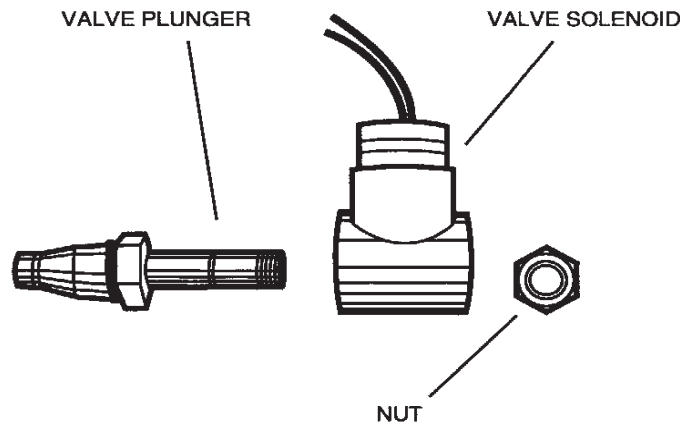

Fig. 10 Down valve

Removing the Turntable Top

NOTE: These instructions apply only to units with the flushmount turntable.

1. Put the lift in the fully-lowered position.
2. Unplug the machine.
3. Use a pair of snap-ring pliers to remove the snap ring in the center of the turntable.
4. Use a lever to lift one edge of the turntable. Lift the turntable away from the machine.
(The turntable weighs about 75 lbs. You will need at least two people to lift this part safely. Be sure to wear heavy gloves when performing this job.)
5. If necessary, you can now remove the carrier plate. The steel balls used in the machine can remain in the lower part of the machine. Do not remove the balls unless you want to degrease the bearings - it can be time consuming to reassemble this part of the machine.
6. In the 43" diameter turntable there are 72 balls. In the 20" diameter turntable there are 48 balls. They are standard chrome-plated steel balls.
7. To reassemble the machine, reverse the steps listed above. **Be sure that every bearing position has a ball.** Check to see that the locking device is intact.

Inspecting and Lubricating the Turntable

NOTE: These instructions apply only to units with the flushmount turntable.

1. Remove the turntable as described in the last section.
2. Lift out the carrier plate. Collect the steel balls (48 balls for the 20" dia. turntable, 72 balls for the 43" dia. turntable).
3. Degrease the carrier plate and the steel balls.
4. Inspect the steel balls for signs of wear. Check several balls for discoloration or breakdown of the chrome layer.
5. Set the carrier plate back in position. **Place each of the balls in one of the bearing positions.** Be sure that every bearing position has a ball. The machine uses the large number of bearings to spread out the weight of the load. If some of the balls are missing, the machine will not work properly, and may wear more quickly.
6. Pack some grease inside the opening of each bearing position on the carrier plate.
7. Work some grease around the center pivot pin and snap ring.
8. To reassemble the machine, reverse the steps listed above.

Troubleshooting Check List

All servicing should be done by qualified personnel. Qualified personnel should be able to read and understand wiring and hydraulic diagrams. They should be able to troubleshoot live electrical circuits safely and in accordance with accepted practice. FOR SAFETY'S SAKE, if in doubt, please contact your distributor or Southworth Products Corporation at (207) 878-0700 or (800) 743-1000.

Before servicing the unit, read and understand this entire section and the section entitled "Operating Instructions."

⚠ WARNING

Before performing any maintenance on this unit, lower the platform completely.

If the platform will not raise:

⚠ CAUTION

If the platform will not raise, do not continue to hold the Up button for more than 2 or 3 seconds. You may damage the pump.

1. The sensor and reflector are mounted at the front of the unit, near the floor level. There may be something blocking the beam of the photo eye toe guard. The reflector may need to be cleaned or replaced.
2. The load may be too heavy. Check the actual weight of the load. The rated capacity of the unit is shown on the name plate.

⚠ WARNING

DON'T CHANGE THE SETTING OF THE RELIEF VALVE. If you do change the setting, this may cause a hydraulic part to fail. The platform may drop suddenly. Someone may be hurt, and the unit and load may be damaged. The hydraulic parts in the lift are designed to handle a certain amount of pressure. The relief valve is set to relieve this pressure before it becomes too great. The relief valve has been included for the protection of all of the workers who use the unit.

3. If the motor is not running, check the electrical plug, the circuit breaker or fuse, and the wiring to the motor.
4. The hydraulic oil level may be low. In order to check the level, lower the unit completely and unplug the power cord. Remove the rear cover on the unit. When the platform is lowered as far as possible, the oil should be about 1/2" to 3/4" inch below the top of the tank. Remove the red plastic plug on top of the tank. Use a dipstick to check the oil level.
5. The motor voltage may be too low. Check the volt- age at the starter when the motor is under load. The supply voltage should be within $\pm 10\%$ of the rating.
6. The tank vent may be plugged. Before operating the unit, you must remove the solid plug from the top of the tank and insert the red plastic vented plug. The vent line must be clear.
7. The suction filter may be clogged. Clean the suction filter as described in the section on "Periodic Maintenance."
8. A vacuum leak may be allowing air into the suction line, causing cavitation (loss of suction) in the pump. Check all fittings in the suction line, and tighten or replace them if necessary.

⚠ CAUTION

If cavitation is allowed to continue, the pump may be damaged, and may have to be replaced.

9. For the platform to raise, the down valve must be de-energized and closed completely. Check for a problem with the wiring to the down valve. Check the solenoid in the valve with a voltmeter. The valve must be clean and free to operate. To check this, remove the solenoid and then the valve. Look for dirt or metal chips which could block the valve action. Clean the valve plunger with kerosene, then blow it clean with

Roll-On™ Level Loader

compressed air. The expansion nut which holds the solenoid should be finger tight only).

10. If the pump has been changed, the coupling may not have been installed between the motor and pump. See the pump assembly in Fig. 9.

If the platform elevates, but fails to hold a load:

1. The check valve may be leaking. Dirt on the valve seat can prevent the valve from closing fully. The check valve is mounted in the base of the pump housing, as shown in Fig. 9. Remove the check valve cap and inspect the valve for dirt or metal chips which may be preventing it from closing. You may be able to restore the seal by lightly rapping the ball into the seat using a 1/4" diameter rod and a small hammer.
2. The down valve may be energized. While the unit is holding a load, the down valve should be de-energized and fully closed. Check the solenoid in the valve with a voltmeter. The valve must be clean and free to operate. To check this, remove the solenoid and then the valve. Look for dirt or metal chips which could block the valve action. Clean the valve plunger with kerosene, then blow it clean with compressed air. The expansion nut which holds the solenoid should be finger tight only!
3. The cylinder may be leaking. Look for oil on the cylinder rod and in the vent line. (This may also occur if the oil tank has been over-filled.) If you find much oil in either place, and the tank is not over-filled, the cylinder must be repacked. See the section in this manual on "Repacking the Cylinder."

If the platform fails to lower:

1. The sensor and reflector for the photo eye toe guard are mounted at the front of the unit, near the floor level. There may be something blocking the beam of the photo eye. The reflector may need to be cleaned or replaced.

2. The down valve may be de-energized. While the platform is lowering, the down valve should be energized and fully open. Check the solenoid in the valve with a voltmeter. The valve must be clean and free to operate. Remove the solenoid, then the down valve. Look for dirt or metal chips which could block the valve action. Clean the valve plunger with kerosene, then blow it clean with compressed air. Before reassembly, depress the plunger manually several times to be sure it moves freely. The expansion nut which holds the solenoid should be finger tight only!

If these steps do not solve the problem, please call the Southworth Products Corp. Customer Service Department at (207) 878-0700 or (800) 743-100

Repacking the Cylinder

The lift in the Roll-On Level Loader unit may use several different types of cylinders. To order a repacking kit and receive repacking instructions, please call the Southworth Parts Department at (207) 878-0700 or (800) 743-1000. When ordering, specify the model number and serial number of the unit.

Adjusting the Chain Tension

NOTE: This adjustment only applies to the #4000 version of this machine

It is very important that the lifting chain be tensioned correctly. As the chain is used, it will tend to stretch a bit. Over time, this can cause it to loosen. The adjustment mechanism is located on the rear of the unit. See Fig. 8.

1. Lower the platform completely and unplug the unit. Remove the plate on the rear of the unit.
2. Loosen the two locking bolts.
3. Find the two tensioning bolts. Loosen the locknuts so you can turn these bolts.
4. Turn the tensioning bolts in or out to change the chain tension. The chain tension should be as tight as possible without lifting the platform off of the floor. The setting should be the same on each side of the mechanism.
5. When the tension is correct, tighten the lock nuts.
6. Tighten the two locking bolts.

ORDERING REPLACEMENT PARTS

Southworth has carefully chosen the components in your lift to be the best available for the purpose. Replacement parts should be identical to the original equipment. **Southworth will not be responsible for equipment failures resulting from the use of incorrect replacement parts or from unauthorized modifications of the machine.**

Southworth will gladly supply you with replacement parts for your Southworth lift. Key parts are identified in Figures 8 through 15. With your order, please include the model number and the serial number of the lift. You can find these numbers on the name plate, which is located on the crossbar at the base of the cylinder(s). When you are ordering parts for a cylinder, also include the cylinder number. This is stamped on the base of the cylinder housing.

To order replacement parts, please call the Parts Department.

Parts are shipped subject to the following terms:

- FOB factory
- Returns only with the approval of our Parts Department.
- Payment net 30 days (except parts covered by warranty).
- Freight collect (except parts covered by warranty).
- The warranty for repair parts is 30 days from date of shipment.

Parts replaced under warranty are on a "charge-credit" basis. We will invoice you when we ship the replacement part, then credit you when you return the worn or damaged part, and we verify that it is covered by our warranty. Labor is not covered under warranty for Parts orders.

Parts Department

Southworth Products Corp

Telephone 207) 878-0700 or (800) 743-1000

FAX : (207) 797-4734

repairparts@SouthworthProducts.com

www.SouthworthProducts.com

2 YEAR WARRANTY

Southworth Products Corp warrants this product to be free from defects in material or workmanship for a period of **2 years** of single shift usage from date of shipment, providing claim is made in writing within that time period. This warranty shall not cover modified designs for special applications, failure or defective operation caused by misuse, misapplication, negligence or accident, exceeding recommended capacities, failure to perform required maintenance or altering or repairing, unless alteration is authorized by Southworth Products Corp. Except as set forth herein, there are no other warranties, express or implied, including the warranties of merchantability and fitness for a particular purpose, all of which are hereby excluded.

Southworth Products Corp makes no warranty or representation with respect to the compliance of any product with state or local safety or product standard codes, and any failure to comply with such codes shall not be considered a defect of material or workmanship under this warranty. Southworth Products Corp shall not be liable for any direct or consequential damages arising out of such noncompliance.

Southworth Products Corp's obligation under this warranty is limited to the replacement or repair of defective components at its factory or another location at Southworth Products Corp's discretion. The Southworth Warranty is for product sold with in North America. For products shipped outside of North America the warranty will be for replacement of defective parts only. Labor is not included. This is buyer's sole remedy. Except as stated herein, Southworth Products Corp will not be liable for any loss, injury or damage to persons or property, nor for direct, indirect, or consequential damage of any kind, resulting from failure or defective operation of said product.

This warranty may be altered only in writing by Southworth Products Corp, Portland, Maine.

SOUTHWORTH

SOUTHWORTH PRODUCTS CORP
P.O. Box 1380, Portland, ME 04104-1380
Telephone: (800) 743-1000 • (207) 878-0700
Fax: (207) 797-4734
www.SouthworthProducts.com

SOUTHWORTH

making work faster, safer, and easier

Southworth is the world class supplier of products designed to improve productivity and enhance safety. Our staff has over 400 years of engineering experience. If one of our standard products does not meet your needs, our engineers can custom design equipment specifically suited to your material handling application.



Spring PalletPal Load Leveler



Lift with Flush Mount Turntable



Portable Container Tilters



Dock Lifts



Roll on Level Loaders



Portable Lifts



Stack-n-Go Powered Stacker



**Floor Height Lifts
Roll-E**

**Floor to
Mezzanine Lifts**



Pallet Rotators



For more information, contact Southworth Products

Telephone (800) 743-1000 Fax (207) 797-4734

Email: salesinfo@SouthworthProducts.com