

DANDY LIFT

(OLD STYLE)

**For model numbers L-150, L-250, A-350W, A-500 & A-800,
this manual is for Serial number L-106701 to L-248492,
and for machines manufactured in June 1994 to August 2011.**

**For model numbers M-500L, F-500L & F-500H,
this manual is for Serial number L-139001 and up,
and for machines manufactured in May 1997 and newer."**

For older machines, contact Southworth Parts Department.



OPERATION & MAINTENANCE MANUAL

With Illustrated Parts List

**SOUTHWORTH PRODUCTS CORP
P.O. Box 1380, Portland, ME 04104**

Telephone: (800) 743-1000 or (207) 878-0700 FAX (207) 797-4734

www.SouthworthProducts.com

July 2015

INDEX

Safety.....	5
Dandy Lift Specifications.....	7
<i>General Information & Operation</i> L150, L250, A350W, A500, A800	9
<i>General Information & Operation</i> M500L, F500L, F500H.....	10
Inspection and Maintenance.....	15
Lubrication.....	15
Illustrated Parts List	18
Warranty	39

Responsibility of Owners and Users

Inspection and Maintenance

The device shall be inspected and maintained in proper working order in accordance with Southworth's owner's manual.

Removal from Service

Any device not in safe operating condition such as, but not limited to, excessive leakage, missing rollers, pins, or fasteners, any bent or cracked structural members, cut or frayed electric, hydraulic, or pneumatic lines, damaged or malfunctioning controls or safety devices, etc. shall be removed from service until it is repaired to the original manufacturer's standards.

Deflection

It is the responsibility of the user/purchaser to advise the manufacturer where deflection may be critical to the application.

Repairs

All repairs shall be made by qualified personnel in conformance with Southworth's instructions.

Operators

Only trained personnel and authorized personnel shall be permitted to operate the equipment.

Before Operation

Before using the device, the operator shall have:

- Read and/or had explained, and understood, the manufacturer's operating instructions and safety rules.

- Inspected the device for proper operation and condition. Any suspect item shall be carefully examined and a determination made by a qualified person as to whether it constitutes a hazard. All items not in conformance with Southworth's specification shall be corrected before further use of the equipment.

During Operation

The device shall only be used in accordance with this owner's manual.

- Do not overload.

- Ensure that all safety devices are operational and in place.

Modifications or Alterations

Modifications or alterations to any Southworth industrial positioning equipment shall be made only with written permission from Southworth.

SAFETY ALERT SYMBOLS AND SIGNAL WORDS

The safety of all persons operating, maintaining, repairing, or in the vicinity of this equipment is of paramount concern. This is a powerful machine with moving parts, and is capable of causing personal injury if proper precautions are not taken. Therefore, throughout this manual, certain hazards have been identified which may occur in the use of the machine, and there are appropriate instructions or precautions which should be taken to avoid these hazards. In some cases, there are consequences which may occur if instructions or precautions are not followed. Below are the symbols and signal words along with their definitions referenced from ANSI Z535.4 - Product Safety Signs and Labels.

Safety Alert Symbols

These are the safety alert symbols. They are used to alert you to potential physical injury hazards. Obey all safety messages that follow this symbol to avoid possible injury or death.



For use with DANGER signal word
(Red Background)



For use with WARNING signal word
(Orange Background)



For use with CAUTION signal word
(Yellow Background)

Signal Words

The meaning of different signal words as defined by ANSI Standard Z535.4 indicates the relative seriousness of the hazardous situation.



(Red Background)

DANGER indicates a hazardous situation which, if not avoided, will result in death or serious injury.



(Orange Background)

WARNING indicates a hazardous situation which, if not avoided, could result in death or serious injury.



(Yellow Background)

CAUTION, used with the safety alert symbol, indicates a hazardous situation which, if not avoided, could result in minor or moderate injury.



(Blue Background)

NOTICE is used to address practices not related to personal injury.



(Green Background)

SAFETY INSTRUCTIONS (or equivalent) signs indicate safety-related instructions or procedures.

SAFETY



WARNING

Failure to obey the instructions and safety in this manual may result in death or serious injury.

Many of the hazards identified in the operating instruction manual are also safety hazards when performed.

Only perform maintenance if:

1. You are trained and qualified to perform maintenance on this machine.
2. You have read, understand and obey:
 - The manufacturer's instructions and safety rules.
 - The employer's safety rules and worksite regulations.
 - All applicable governmental regulations
3. You have the appropriate tools, lifting equipment and a suitable workshop.

WARNING

While performing maintenance do not work on a raised lift. Lay the lift on its side when working on any Dandy lift.

PRIOR TO OPERATING THE LIFT:

The Dandy Lift is designed to provide safe operation. By following these safety rules, the operator will avoid injury to him/her self or others and also damage to the Dandy Lift, other equipment or structures.

In order to ensure safe and efficient use, the operator should fully familiarize himself with the contents of this manual prior to handling the unit. Also refer to any precautionary labeling on the machine for guidance as you do the work.



1. Keep non-authorized personnel away from the unit during operation.
2. Do not sit, stand or ride on the tabletop.
3. Do not load with more than the rated capacity.
4. Avoid any protrusion beyond the edge of the platform; load should always be centered.
5. Keep hands or feet clear at all times.
6. Avoid rapid lowering of the platform while loaded.
7. The platform must be lowered when the unit is being transported.
8. During the loading/unloading operation, do not release parking brake.
9. Do not raise/lower the platform on a sloped or uneven surface.

For safe and efficient use of the unit, lubrication and servicing is necessary. At initial start up, lubricate all required parts in accordance with lubrication section.

Maintenance and adjustment work must be performed while lift is not loaded, and use an appropriate support to avoid accidental lowering. This support is always recommended when working on a lift.

DANDY LIFT SPECIFICATION

MODEL	L-150	L-250	A-500	A-800	A-350W
CAPACITY – lb. (kg.)	330 (150)	550 (250)	1100 (500)	1760 (800)	770 (350)
PLATFORM LOWERED HEIGHT – inches (mm)	8.3 (210)	9.5 (245)	11.8 (300)	13.0 (330)	13.6 (345)
VERTICAL TRAVEL – inches (mm)	20.7 (525)	22.2 (565)	24.8 (630)	27.2 (690)	36.2 (920)
PLATFORM RAISED HEIGHT – inches (mm)	29.0 (735)	31.8 (810)	36.6 (930)	40.2 (1010)	49.8 (1265)
HANDLE HEIGHT – inches (mm)	36.0 (915)	36.2 (920)	37.8 (960)	38.8 (985)	37.8 (960)
PLATFORM WIDTH x LENGTH – inches (mm)	17.7 x 28.0 (450 x 710)	19.7 x 31.5 (500 x 800)	23.6 x 35.8 (600 x 910)	23.6 x 39.4 (600 x 1000)	23.6 x 35.8 (600 x 910)
OVERALL WIDTH x LENGTH – inches (mm)	17.7 x 34.5 (450 x 875)	19.7 x 38.2 (500 x 970)	23.6 x 42.1 (600 x 1070)	23.6 x 45.5 (600 x 1155)	23.6 x 42.1 (600 x 1070)
FOOT PEDAL STROKES TO ELEVATE	10	20	45	56	45
FOOT PEDAL FORCE REQUIRED – lb. (kg)	77.0 (35)	52.8 (24)	59.4 (27)	88.0 (40)	66.0 (30)
CASTERS FRONT	4” RIGID	4” RIGID - HD	5” RIGID	6” RIGID – URETHANE	5” RIGID
CASTERS REAR	4” SWIVEL	4” SWIVEL HD	5” SWIVEL	6” SWIVEL URETHANE	5” SWIVEL
PARKING LOCK/ FLOOR LOCK	YES	YES	YES	YES	YES
COLOR – PLATFORM/FRAME	BLUE/BLUE	ORANGE/BLUE	YELLOW/BLUE	GRAY/BLUE	YELLOW/BLUE
TARE WEIGHT – lb. (kg)	77.0 (35)	118.8 (54)	193.6 (88)	250.8 (114)	231.0 (105)

Note: Casters are rubber except where noted. Specifications are subject to change without notice.

MODEL	M/F – 500	F – 500H
CAPACITY – lb. (kg.)	500	500
PLATFORM LOWERED HEIGHT – inches (mm)	80	90
VERTICAL TRAVEL – inches (mm)	670	820
PLATFORM RAISED HEIGHT – inches (mm)	750	900
HANDLE HEIGHT – inches (mm)	945	945
PLATFORM WIDTH x LENGTH – inches (mm)	500 X 940	500 X 1100
OVERALL WIDTH x LENGTH – inches (mm)	500 X 1404	500 X 1568
FOOT PEDAL STROKES TO ELEVATE	16	20
FOOT PEDAL FORCE REQUIRED – lb. (kg)	40	40
CASTERS FRONT	70mm (Urethane)	70 (Urethane)
CASTERS REAR	150mm	150mm
PARKING LOCK/ FLOOR LOCK	Caster stopper on two rear wheels	Caster stopper on two rear wheels
Pedal stroke fully loaded	55	67
TARE WEIGHT – lb. (kg)	76kgs	89kgs

GENERAL INFORMATION & OPERATION

L150, L250, A350W, A500, A800

A. The lift is packed in a cardboard box. Assembling of the handle with lift-lowering lever and jack up pedal is required.

WARNING:

Assembly work must be done on a flat surface.
Wheels must be chocked to prevent accidental rolling of the unit.

To complete assembly of the lift:

1. Remove nuts and spring washers from the end of handle and insert the handle and lowering lever rod simultaneously into hole on platform and frame. If rod end of lowering lever slips out of the connecting sleeve or wedge of rod end does not hold in the connecting sleeve, adjustment may be required. Tighten handle and lowering lever using removed nuts and washers.

B. If air enters the hydraulic pump during transportation or in storage, lift may not raise even when the pedal is first pumped. In this case, place the unit in the normal position and push the pedal all the way down (approximately ten times). This should clear the trapped air from the self-bleeding system. Check to see that the jack is functioning properly.

C. Parking brake (floor lock) will require adjustment. Adjust the contact shoe so that you can see it make contact with the floor with some force and then make sure it can still be released without difficulty.

GENERAL INFORMATION & OPERATION

M-500L, M-500L, F-500H

ASSEMBLY:

To use the M-500L or F-500 L/H, stand the hydraulic cylinder upright and attach the release lever and the handle.

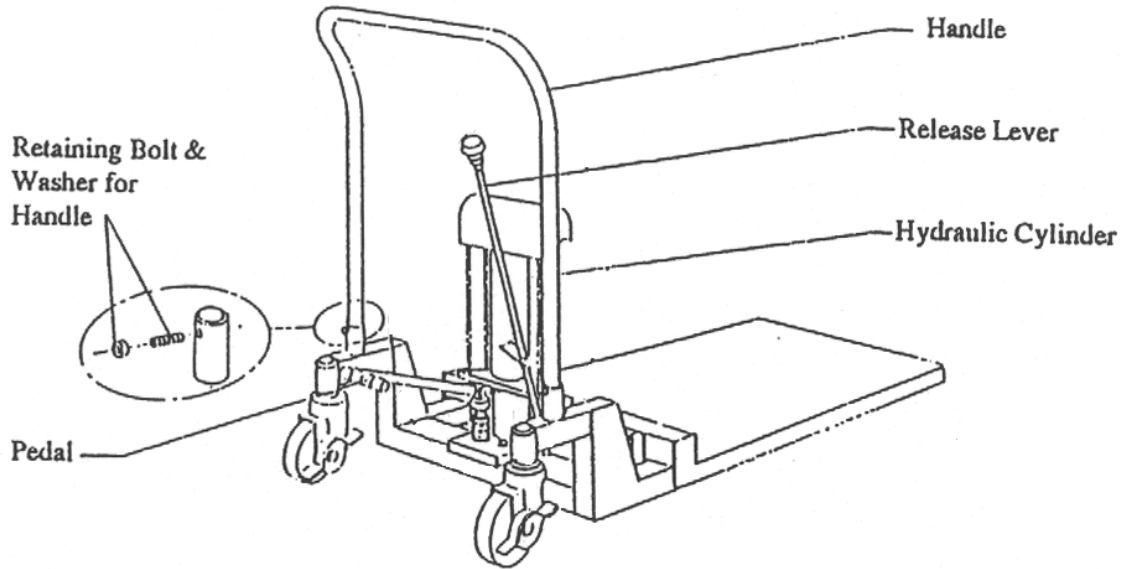

Figure 1: General View (Bed Down)

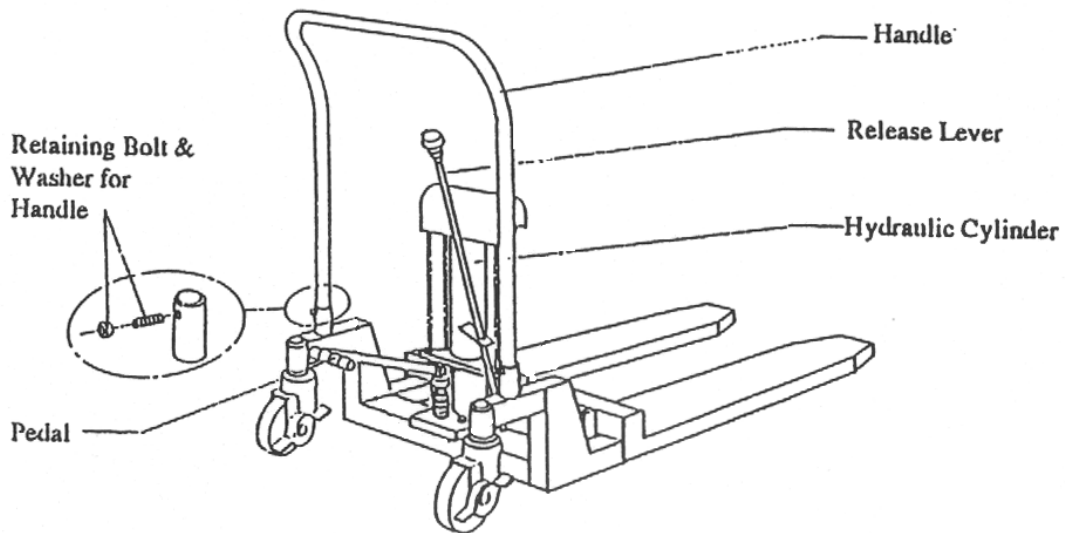

Figure 2: General View (Fork Down)

1. The illustration below shows the hydraulic cylinder unit in its collapsed position for transporting.
2. Remove the retaining bolt and washer shown in the illustration.
3. Raise the hydraulic cylinder (2) and stand it up vertically and fasten the base plate of the hydraulic cylinder to the frame with the retaining bolt and washer.
4. Loosen the screw on the retaining ring of the release lever out and insert the release lever in the hole of the holding arm, placing the crevice of the release lever on the pivot. See figure 2.

Figure 2

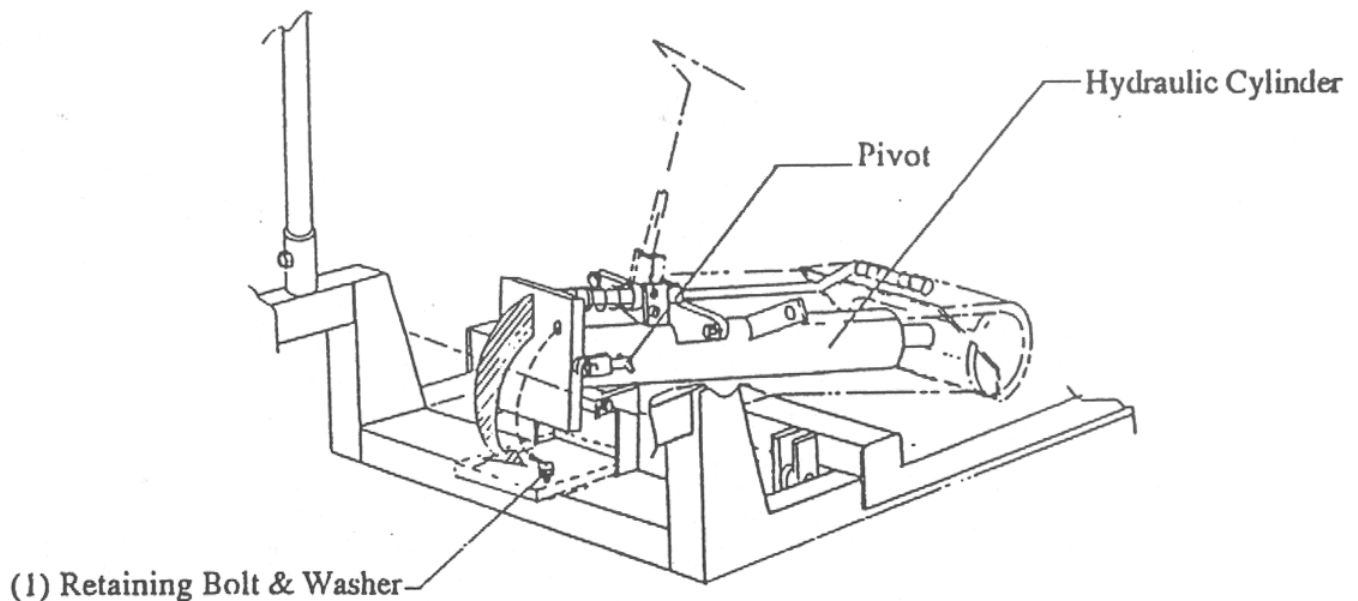
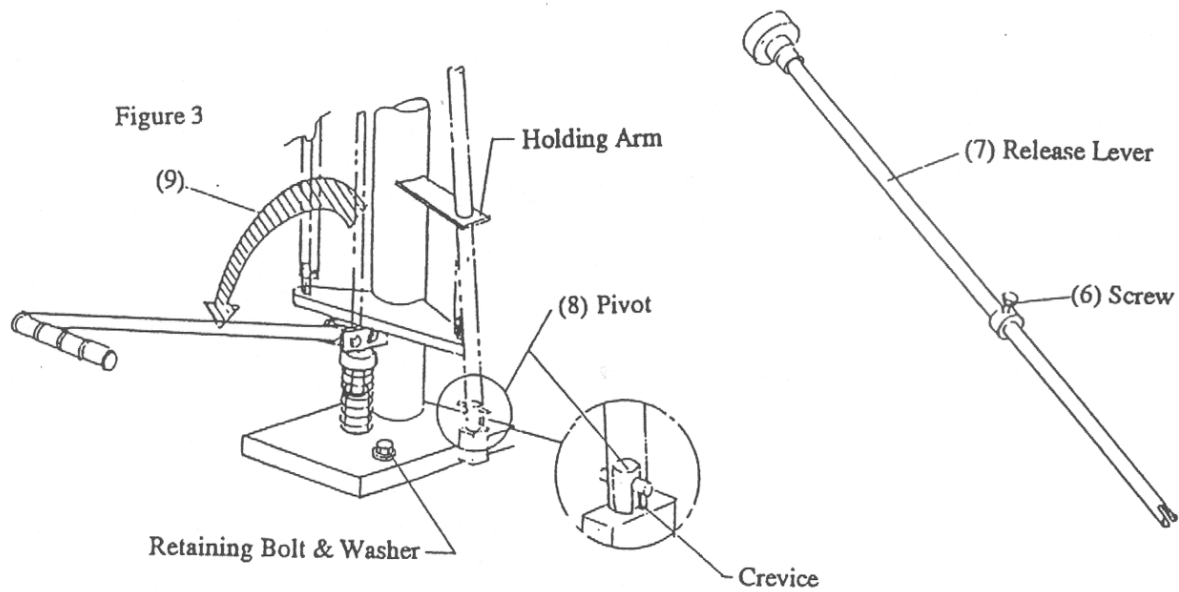
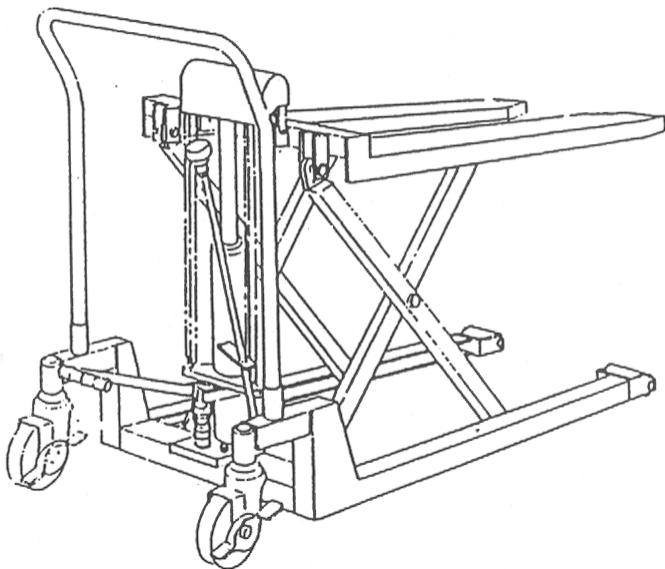

Figure 2. An exploded view.

5. Fasten the screw on the retaining ring to contact to the reverse side of the holding arm to prevent disconnection between the release lever and the pivot.
 6. Lower the pedal folded against the hydraulic cylinder in the direction of the arrow.
- This completes the assembly of the hydraulic cylinder, pump and release lever.



2. Fastening the Handle



F-500L/H Fork Up Position

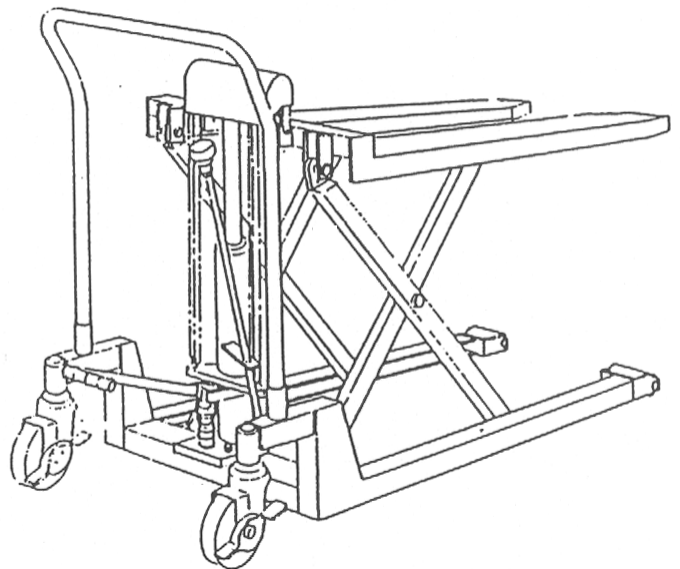

M-500L Bed Up Position

A. Fastening the Handle

Remove the retaining bolt and nut of the handle unit. Insert the handle in the mounting flange so that the handle curves toward the operator.

Fasten the handle on the left and right with retaining bolts, tighten the nuts.

- B. Air sometimes enters the hydraulic cylinder during transport and the fork/platform may not rise. In such a case, pump the pedal about ten times and leave it for about ten minutes. The air will be released from this self-bleeding system and the fork/platform will rise.
- C. Prior to operating the unit.

WARNING!

In order to ensure safe and efficient use, the operator should fully familiarize himself with the contents of this manual prior to handling the unit. (Refer to sticker labels for operational guidance.)

OPERATION: RAISE/LOWER

CAUTION:

Lock parking brake securely. Do not raise/lower the platform on a sloped surface.

To raise: Pump jack pedal repeatedly.

NOTE: If the platform did not lift up properly, adjustment must be made in accordance with the inspection and maintenance section.

WARNING:

Keep hands or feet clear of the platform and the frame.

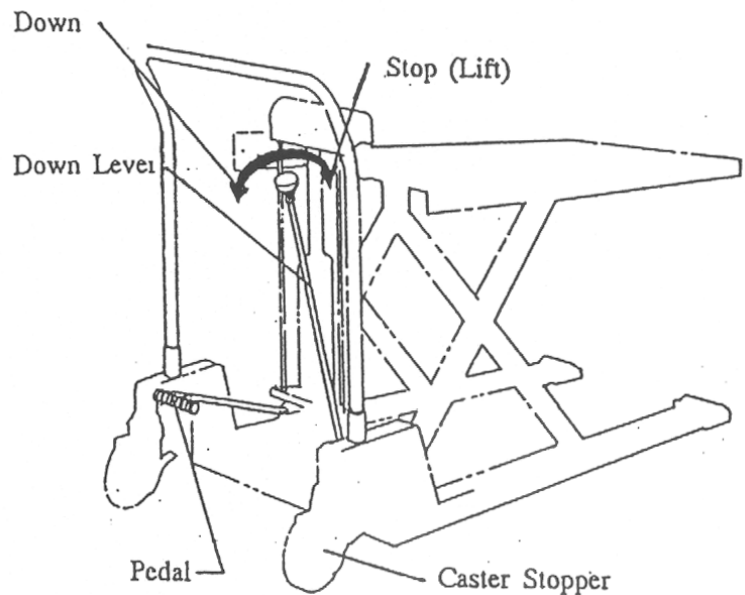

To lower: Turn lowering lever slowly in a clockwise direction. As soon as the platform starts down, do not turn the lever more – maintain as is. The platform will continue lowering smoothly. The lowering operation must be made slowly. By turning the lever, lowering speed can be adjusted.

NOTE: When load is on the platform, turn lever only the minimum amount to prevent rapid decent of the platform. When the platform is empty, turn lever fully.

CAUTION:

Adjust stopper bolt when lift lowers too rapidly.

To maintain the platform at an intermediate point:

- The platform stops when pumping up pedal is stopped.
- When the lowering lever is released, the platform stops lowering and will maintain the position.

Loading/Unloading

CAUTION:

Do not allow load to overhang the edge of the platform. Do not load more than specified capacity.

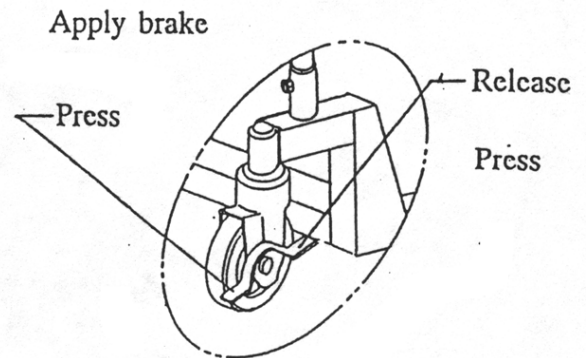

Parking Lock

1. Parking brake (floor lock) must be actuated during parking and lifting or lowering of the platform.

WARNING:

Floor lock (parking brake) is fixed to prevent shoe from falling off during shipment. Do not actuate as is. The following adjustment must be made as soon as the unit is assembled.

2. Adjustment of the shoe on the parking brake

- Adjustment work must be done on flat surface.
- Step on lock lever until it clicks actuating the brake.
- Screw shoe down by rotating it in a clockwise direction so that it touches the floor.
- Step on release lever to release the brake. Then rotate the shoe clockwise an additional two turns to provide firm contact with the floor.

NOTE: By doing the above adjustment, shoe will compress by 1/8", assuring firm contact with the floor. If perfect braking is not achieved, repeat above adjustment.

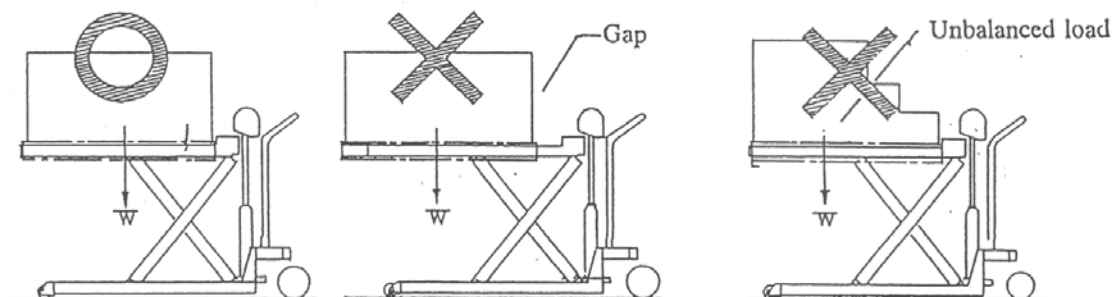

CAUTION:

Make sure floor lock is set during lifting or parking.

INSPECTION AND MAINTENANCE

Dandy Lifts do not require special maintenance, other than lubrication and periodic inspection. Inspection and maintenance should be made in accordance with the following procedure for smooth and efficient operation.

CAUTION:

During lubrication, inspection and maintenance the platform must be empty.

WARNING:

If the platform needs to be raised for access to lubrication points, the unit should be laid over on its side. Do not put your hands into a raised lift.

A. Lubrication

Lubrication must be made in accordance with the following table:

Part	Lubrication Material	Fig. & Item No. To be referred	x
Rail (frame)	Grease	N1-3	*(S-3)
Roller (of jack lever)	Grease (grease zirc)	N1-9-12	(S-9-12)
Hinge on Scissors	Machine Oil	N1-2-1	(S-2-1-1)
Stay	Machine Oil	N1-2-4	(S-2-4)
Lifting up box (moving part)	Machine Oil	N1-2-1-2 N1-2-3	(S-2-1-2)
Parking Lock	Machine Oil	N1-7	*(S-7)
Lowering Lever (moving part)	Machine Oil	N1-8	(S-8)
Jack Pedal	Grease, One 1 grease zirc	N1-9-4	(S-9-2)
Other contacting and Sliding area	Grease/Machine Oil		
Jack Oil	Mitsubishi Hydrofluid EP-32 or equivalent ("Shell" Tullus L32)		

*() Is to be applied to L-150 only

B. Inspection and Maintenance

Prior to use of the unit, check for damage, deformation or cracks on the body.

NOTE: During inspection, the platform must be empty.

Remove foreign substance on scissors guide from the frame and rail.

Check lifting performance of the platform in accordance with provision of operation.

Check lifting up performance.

Check stopping performance at any desired height.

Check lowering speed and smooth action of the lowering lever.

C. Adjustment

1. Malfunctioning up/down of the platform.

If the platform does not lift up or hold in any position even while jack is pumped.

- Air is in jack unit.

To bleed jack unit: Pump ten times then let it set for about ten minutes; the unit will self-bleed.

- Lowering valve does not close completely.

Valve on jack will not be closed perfectly. In this case, adjustment is required in accordance with the procedure below:

For L-150, L-250, A-350W, A-500 and A-800.

Loosen nut on connecting Rod-1 and turn part (A), shown in right figure, in counterclockwise direction one turn. Tighten the lock nut. Check for normal raising and lowering. If the above adjustment does not result in normal operation, repeat once more. If the above adjustment does not result in normal operation, check for problem in other areas.

2. Adjustment of lowering speed of the platform. When lowering lever is pulled fully in with no load on the bed, the platform should lower from maximum height to lowest position in about twenty-five seconds. In case the speed is abnormal, adjustment is required as follows:

- To increase lowering speed when lowering

Lever is pulled fully, loosen lock nut and turn stopper screw in clockwise direction.

To decrease lowering speed, screw should be turned in clockwise direction.

After adjustment is completed, tighten lock nut.

D. Removing Scissors Assembly

1. Raise table up to maximum height and lay over on its side.
2. Loosen and remove screw (p/n 0218825) from lift box.

ROD – 2

R pin

Rod – 3

Longer support	Length	Section
For	A 7" A-350W	1" x 1.5"
	B 3.25"	1" x 1.5"
For	L-150	A 11.5"
		B size is not useable
	L-250	A 9 7/8"
	A-500	
	A-800	B 3.25"
		1" x 1.5"
		1" x 1.5"

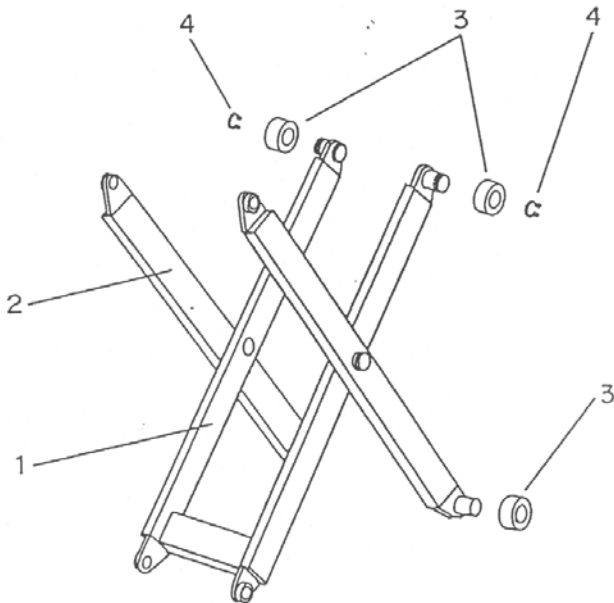

M-500L, F-500L Scissors

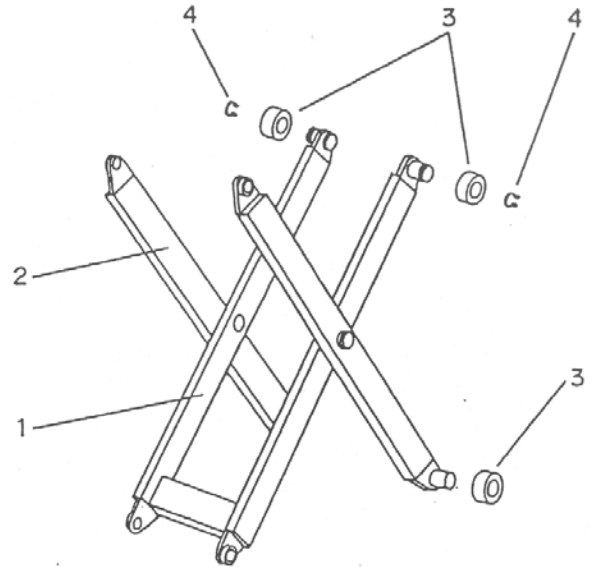

F-500H Scissors

ILLUSTRATED PARTS LIST

FOR MODELS L-250, A-500, A-800 and A-350W, refer to figure 1 (item N) illustration and part number against Figure 2 (item S) for L-150.

To place your part order, both model and serial number must be specified together with name of each part and required quantity.

For example:

Model No.	Serial No.	Item No.	Name & (P/N)	Quantity
A-5000			N1-6-1	Front Caster
	1 (Ref. Page 24)		(p/n 38-WK-130R)	

Item No.	Description	Qty	L-250	A-500	A-800	A-350W
N1-1	Platform	1				
-1	Platform plate	1	NB201010	ND201010	NE201010	NC201010
-2	Screw & Nut	4	0218820	0218825	0218825	0218820
	Washer & Spring	4	0980853	0980853	0980853	0980853
-3	Plastic fitting for stay	2	ND391032	ND391032	ND391032	ND391032

FOR L-250, A-500, A-800, A-350W

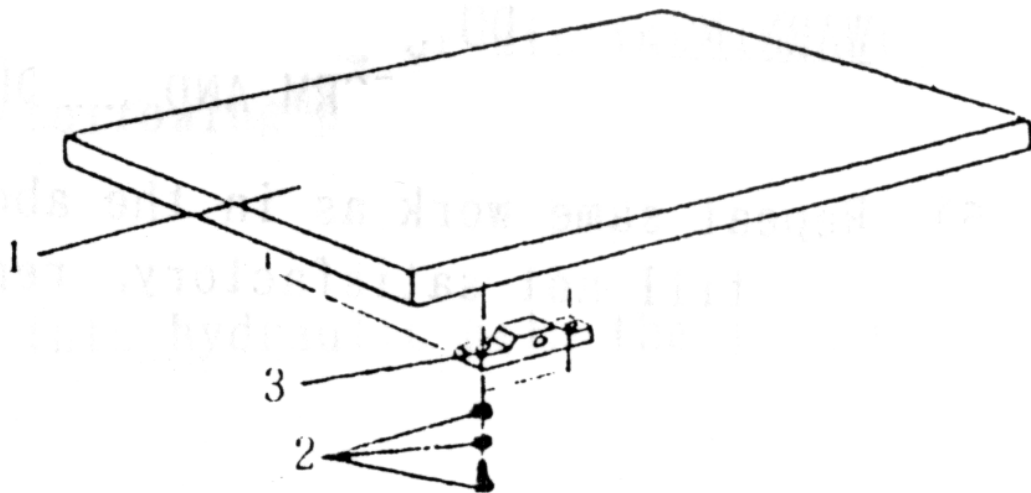

Fig. N1-1 Platform

<u>Item No.</u>	<u>Description</u>	<u>Qty</u>	<u>L-250</u>	<u>A-500</u>	<u>A-800</u>
N1-2	Scissors Device	1			
1-1	Scissor (outer)	1	NB310012	ND310011	NE310010
	(inner)	1	NB320012	ND320010	NE320010
	Pin. Pivot		NB370000	ND340070	NE340070
-1-2	Lift Box	1	NB340012	ND340011	NE340011
	Pin. Pivot	2	NB350002	ND350001	NE350001
	Ring, Retaining	2	0321601	0322001	0322501
-2	Roller (Upper)	4	NB351002	ND351001	NE351001
	(Lower)	4	NB361001	ND361001	ND361001
-3	Washer	2	0910812	0910812	0910812
-4	Stay	2	ND391012	ND391012	ND391012
-5	Jack Plate	1	NB340050	ND340051	NE340050
	Screw	1	0218825	0218825	0218825

L-250, A-500 A-800

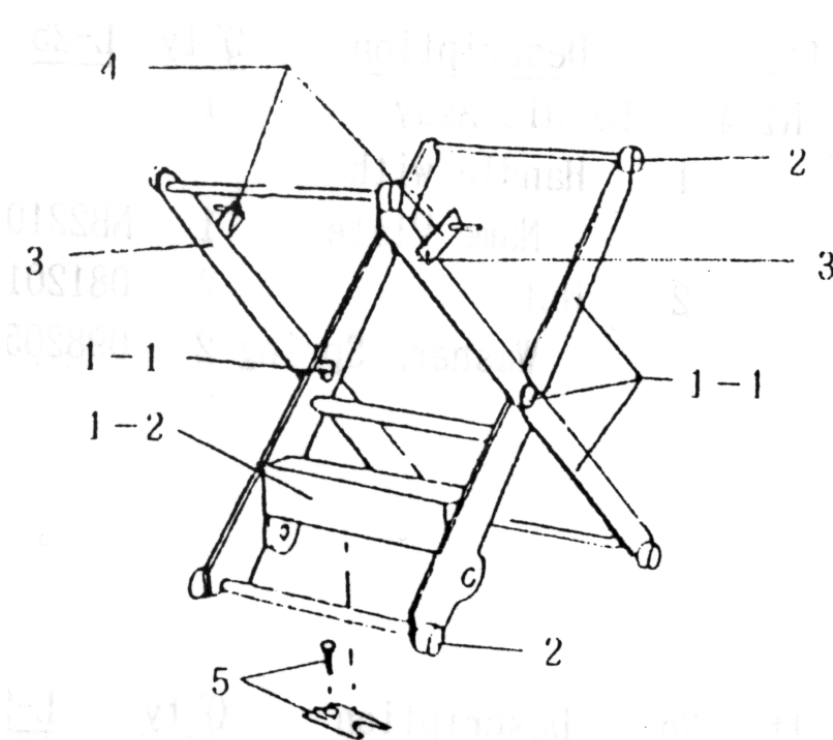

Fig. N1-2 Scissors Device

Item #	Description	Qty	A-350W	
N1-2'	Scissors Device	1		
-1-1	Scissors (lower)	1	(out side) NC320011	(in side) NC310010
-1-2	Scissors (upper)	1	(out side) NC32001B	(in side) NC31001B
	Pin Pivot	4	ND340070	
-3	Lift Box	1	NC340011	
	Ring. Retaining	2	0322001	
-2	Roller	4	(upper) ND351001	(lower) ND361001
-3	Washer	2	0910812	
-4	Stay	2	ND391012	
-5	Jack Plate	1	ND340051	
	Screw	1	0218825	
-6	Guide	1	NC190010	
	Bolt	1	0111020	
	Washer, Spring	1	0981014	

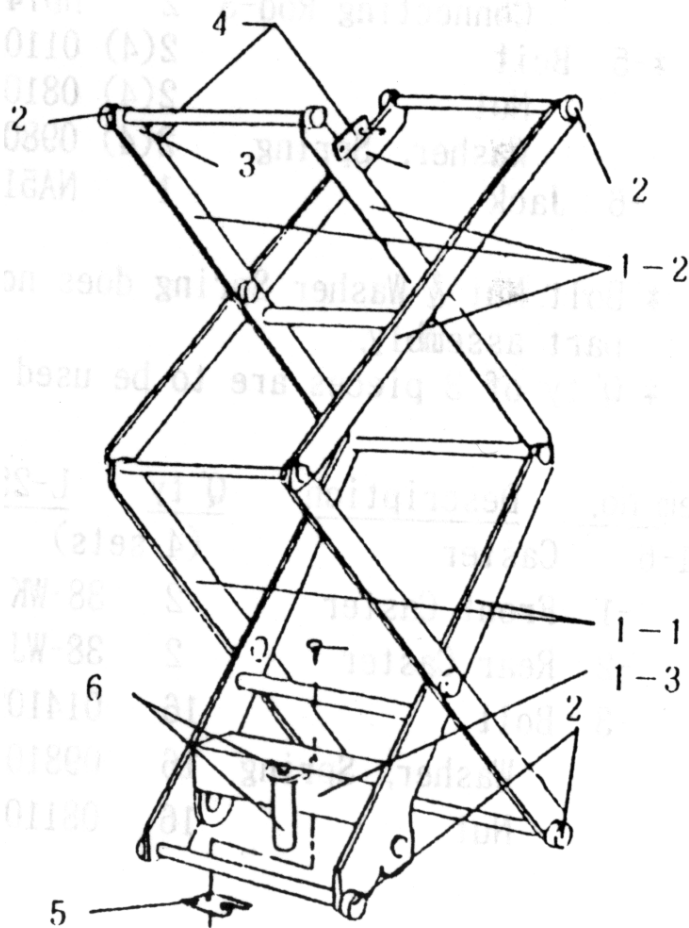

Fig. N1-2' Scissors Device

<u>Item No.</u>	<u>Description</u>	<u>Qty</u>	<u>L-250</u>	<u>A-500</u>	<u>A-800</u>	<u>A-350W</u>
N1-3	Frame (not illustrated)	1	NB101002	ND101002	NE101001	NC101001

FOR L-250, A-500, A-800, A-350W

<u>Item No.</u>	<u>Description</u>	<u>Qty</u>	<u>L-250</u>	<u>A-500</u>	<u>A-800</u>	<u>A-350W</u>
N1-4	Handle Assy	1				
-1	Handle with Name plate	1	NB221012	ND220011	ND220011	ND220011
-2	Nut	2	0812011	0812011	0812011	0812011
	Washer, Spring	2	0982057	0982057	0982057	0982057

Fig. N1-4 Handle Assembly

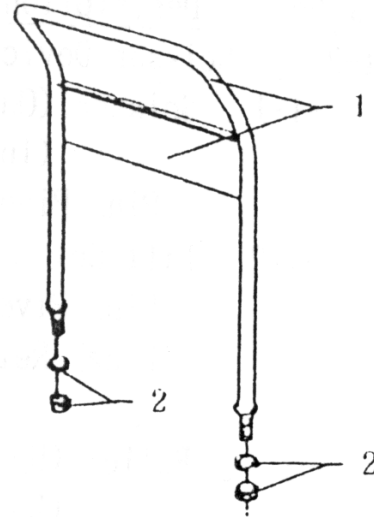

<u>Item #</u>	<u>Description</u>	<u>Qty</u>	<u>L-250</u>	<u>A-500</u>	<u>A-800</u>	<u>A-350W</u>
N1-5	Jack Assy	1	*(NA511AA1)	*(ND511AA1)	*(NE521AA0)	*(ND511AA1)
-1	Piston	1	ND520010	ND520010	NE520010	ND520010
-2	Spring, Comp	1	NB531001	ND531001	NE531001	ND531001
-3	Cap	1	ND540010	ND540010	NE540010	ND540010
	Pin, Spring	1	0460820	0460820	0460824	0460820
-4	Nut "U"	1	0810881	0810881	0810881	0810881
	connect rod-3	2	ND741010	ND741010	ND741010	ND741010
*-5	Bolt	2(4)	0110825	0110825	0110830	0110825
	Nut	2(4)	0810811	0810811	0810811	0810811
	Washer, sprg	2(4)	0980853	0980853	0980853	0980853
-6	Jack	1	NA510000	ND510000	NE510000	ND510000

* bolt nut & washer spring are not included in standard part assembly.

* Quantity of 3 pieces are to be used for A—800

Fig. N1-5 Jack Assembly

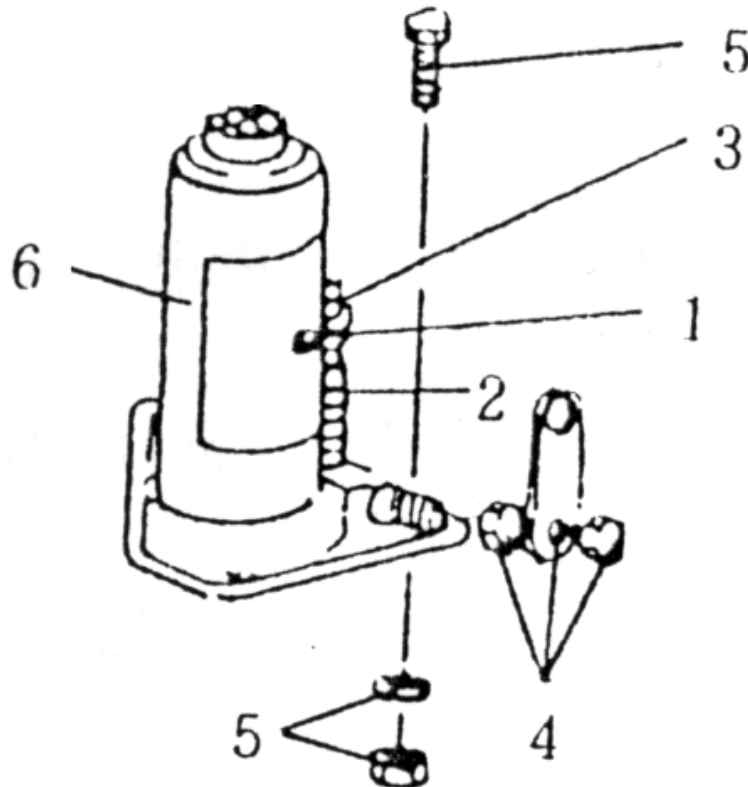

Item #	Description	Qty	L-250	A-500	A-800	A-350W
N1-6	Caster	(4 sets)				
-1	Front Caster	2	38-WK-100R	38-WK-130R	38-WK-150U	38-WK-130R
-2	Rear Caster	2	38-WJ-100R	38-WJ-130R	38-WJ-150U	38-WJ-130R
-3	Bolt	16	01410200	0141020	0141020	0141020
	Washer, sprg	16	0981064	0981064	0981064	0981064
	Nut	16	0811011	0811011	0811011	0811011

Fig. N1-6 Caster

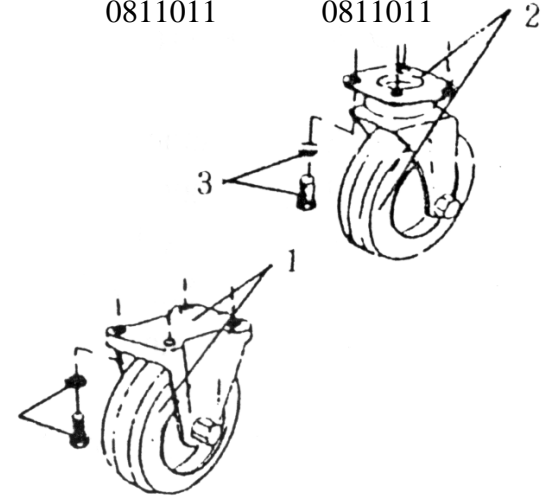

Item #	Description	Qty	L-250	A-500	A-800	A-350W
N1-7	Parking Lock					
-1-1	Floor Lock	1	ND810000	ND810000	ND810000	ND810000
-1-2	Spring. Tensn	1	ND810220	ND810220	ND810220	ND810220
-1-3	Shoe	1	ND810200	ND810200	ND810200	ND810200
-2	Bolt	4	0110820	0110820	0110820	0110820
	washer, sprg	4	0980853	0980853	0980853	0980853
	nut	4	0810811	0810811	0810811	0810811

Fig. N1-7 Parking Lock

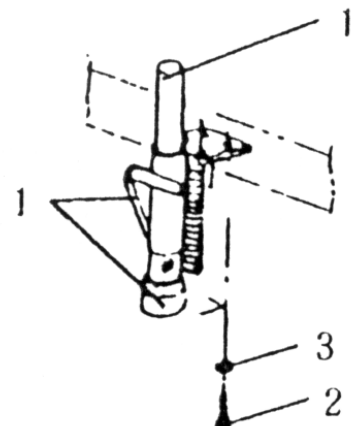

Item #	Description	Qty	L-250	A-500	A-800	A-350W
N1-8	Lowering Lever Assy	1				
-1	Screw	2	0216616	0216616	0216616	0216616
	washer, sprg	2	0980652	0980652	0980652	0980652
	nut	2	0810611	0810611	0810611	0810611
-2	pin	1	ND720020	ND720020	ND720020	ND720020
	pin, spring	1	0460314	0460314	0460314	0460314
-3	fixed support	1	ND720010	ND720010	ND720010	ND720010
-4	spring, tension	1	ND730000	ND730000	ND730000	ND730000
-5	screw (stopper)	1	0216630	0216630	0216630	0216630
	nut	1	0810611	0810611	0810611	0810611
-6	Lowering lever	1	NB711012	ND710011	NB710011	NB710011
-7	sleeve, conne.	1	ND740052	ND740052	ND740052	ND740052
-8	pin, spring	2	0460420	0460420	0460420	0460420
-9	crank	1	ND740031	ND740031	ND740031	ND740031
-10	washer	2	0910813	0910813	0910813	0910813
-11	pin "R"	2	0340808	0340808	0340808	0340808
-12	spring tension	1	NB760000	ND760000	ND760000	ND760000
-13	connt. Rod ½	1	NB741061	ND740061	NE740061	NC740061
	nut	1	0810811	0810811	0810811	0810811
-14	connt. Rod-3	1	ND741010	ND741010	ND741010	ND741010
-15	nut "U"	2	0810881	0810881	0810881	0810881

Fig. N1-8
Lowering Lever
Assembly

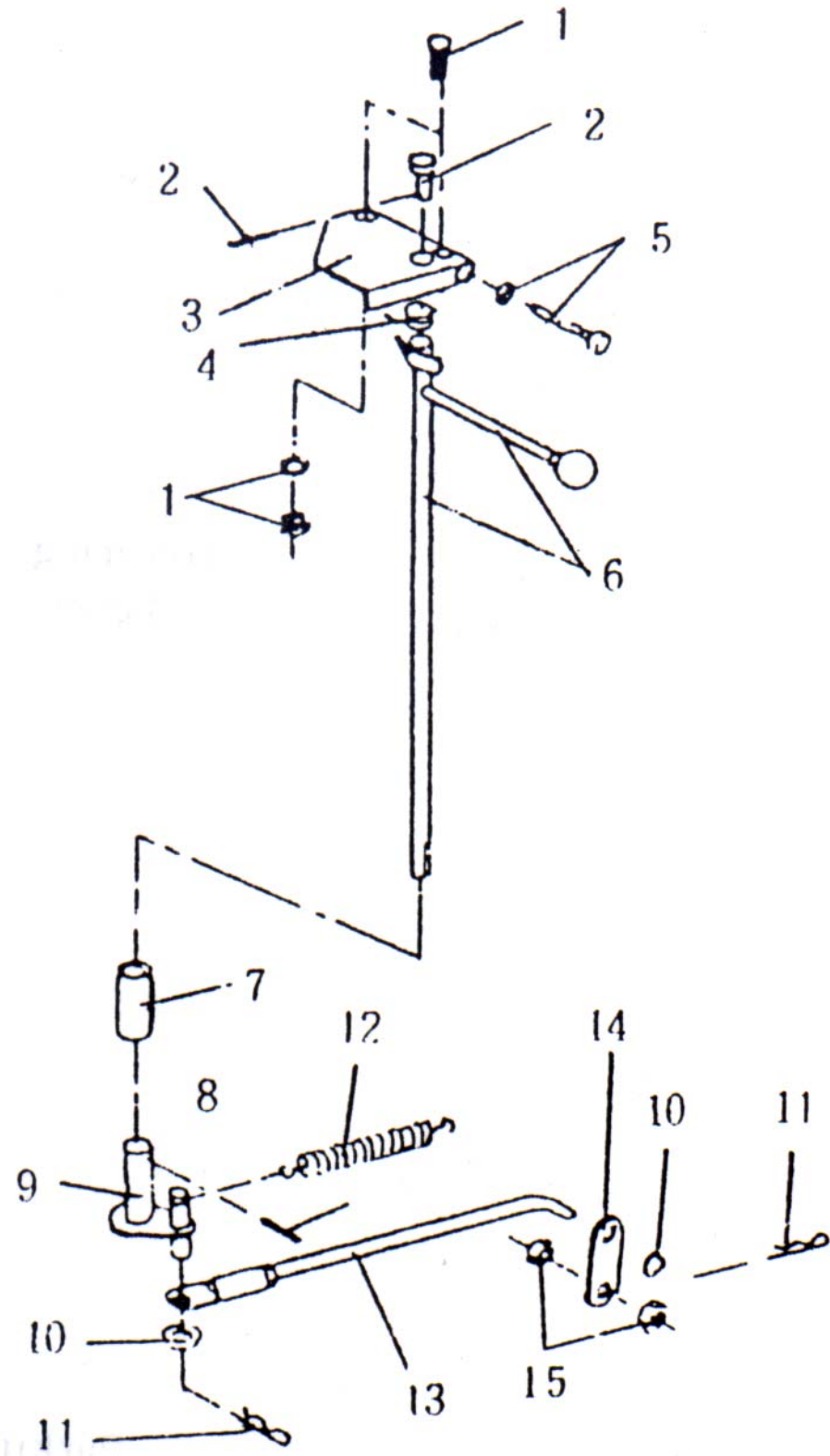

Item #	Description	Qty	L-250	A-500	A-800	A-350W
N1-9	Jack Pedal Assembly					
-1	pedal, jack	1	ND430010	ND430010	ND430010	ND430010
-2	pin, split	1	0360630	0360630	0360630	0360630
	nut, castle	1	0811652	0811652	0811652	0811652
-3	shaft (bolt)	1	0111675-17	0111675-17	0111675-17	0111675-17
-4	receiver, pedal	1	NB440012	ND440012	ND440012	ND440012
-5	Pin "R"	1	0340808	0340808	0340808	0340808
-6	Pin, split	2	0362520	0362520	0362520	0362520
	washer	2	0910812	0910812	0910812	0910812
-7	pin-1	2	ND420040	ND420040	ND420040	ND420040
-8	connt. Rod	1	NB421012	ND421012	NE421012	NC421012
	bush	2	ND410070	ND410070	ND410070	ND410070
-9	screw, retain	1		0212410	0212410	0212410
-10	shaft for lever	1	ND140061	ND140061	NE140061	ND140061
-11	lever, jack	1	NB410011	ND410011	ND410011	ND410011
-12	pin-2	1	ND410091	ND410091	ND410091	ND410091
	ring, retain "E"	1	0320605	0320605	0320605	0320605
-13	Roller	1	ND410060	ND410060	ND410060	ND410060
-14	grease nipple	2	0040600	0040600	0040600	0040600
	washer	2	0910612	0910612	0910612	0910612

Fig. N1-9 Jack pedal Assembly

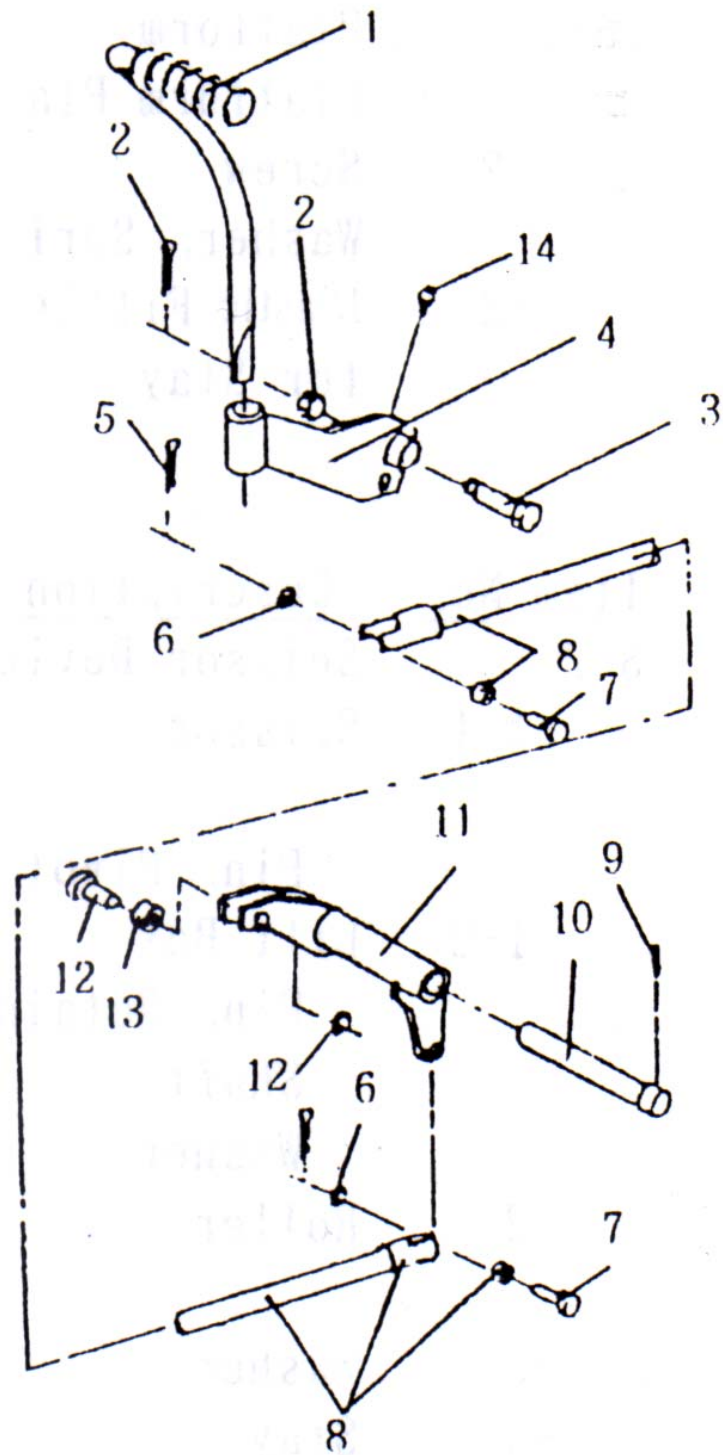

FOR L-150

Item No.	Description	Qty	L-150
S-1	platform	1	
-1	platform plate	1	NA210012
-2	screw	4	0218825
	washer, spring	4	0980853
-3	plastic fitting for stay	2	ND391032

Fig. S-1 Platform

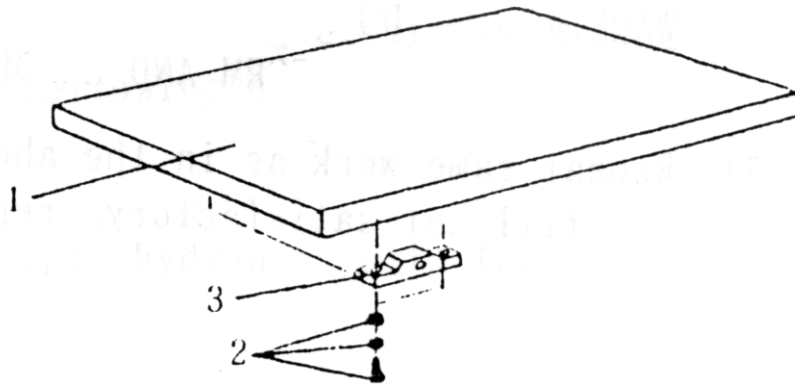

Item No.	Description	Qty	L-150
S-2	Scissors Device	1	
-1-1	Scissors	1(outside) 1(inside)	NA320012 NA310012
	Pin. Pivot	2	NA370002
-1-2	Lift Box	1	NA340012
	Pin Retaining	2	0321601
	Shaft	2	NA381002
	Washer	2	0911615
-2	Roller	4	NA351002
		4	NA361002
-3	Washer	2	0910812
-4	Stay	2	ND391012
-5	Jack Plate	1	NA340052
	screw	1	0218825

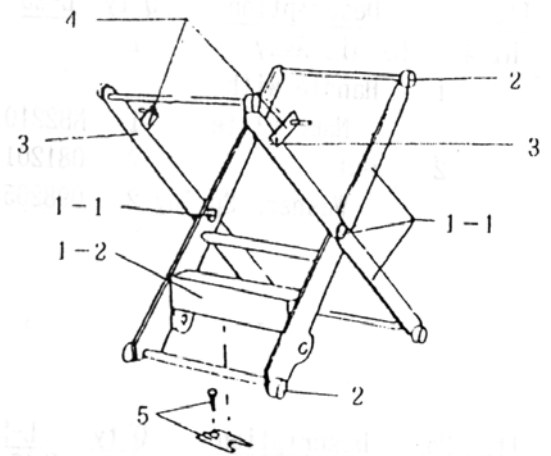

Fig. S-2 Scissors Device

Item No.	Description	Qty	L-150
S-3	Frame (not illustrated)	1	NA100002

Item No.	Description	Qty	L-150
S-4	Handle Assembly	1	
-1	Handle with Name plt	1	NA221012
-2	Nut	2	0812011
	washer, spring	2	0982087

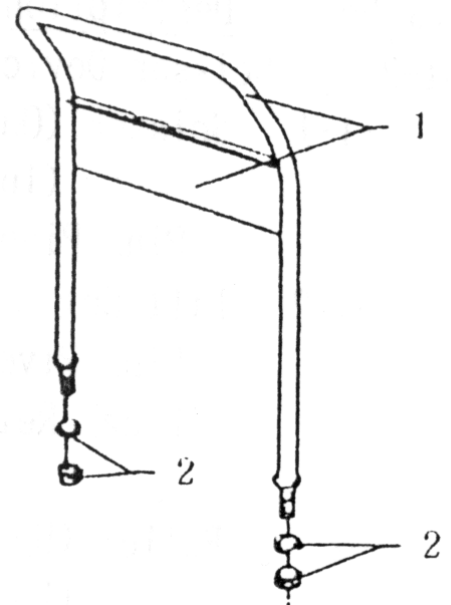

Fig. S-4 Handle Assembly

Item No.	Description	Qty	L-150
S-5	Jack Assembly	1	*(NA511AA3)
-1	Piston	1	NA510022
-2	Spring Compression	1	NA531003
-3	Cap	1	NA540012
	Pin, Spring	1	0460832
-4	Nut "U"	2	0810881
	Connecting Rod-3	1	ND741010
-5	Bolt	2	0110825
	Nut	2	0810811
	Washer, spring	2	0980853
-6	Jack	1	NA510002

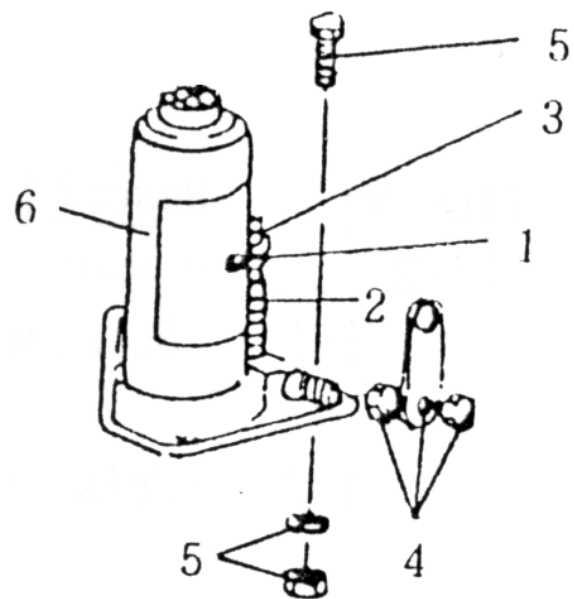

Fig. S-5 Jack Assembly

**standard spare assembly for jack does not include S5-5- bolt, nut and washer.*

Item No. Description Qty L-150

S-6	Caster applicable to s/n 26034 and up.	1	
-1	Front Caster	2	K-SKK-R100
-2	Rear Caster	2	J-SKK-R100
	Washer, spring	16	0980865
-3	Bolt, washer, spring	16	0980865
	Nut	16	0810811

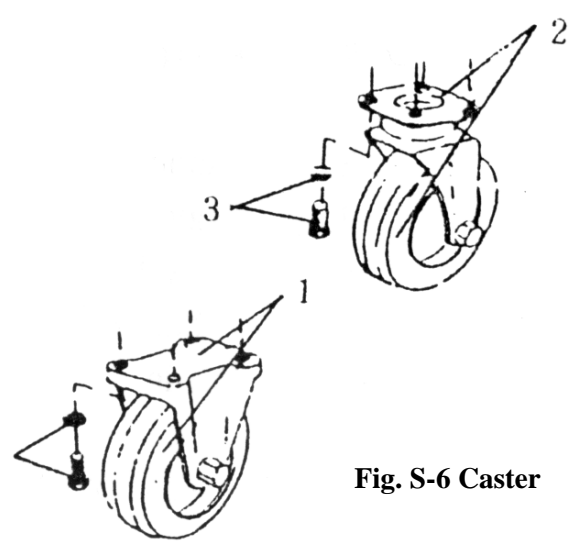

Fig. S-6 Caster

Item No. Description Qty L-150

S-7	parking lock	1	
-1-1	Floor Lock	1	NA810002
-2	Spring, tension	1	ND810220
-3	Shoe	1	ND810200
-2	Bolt washer	4	0980853

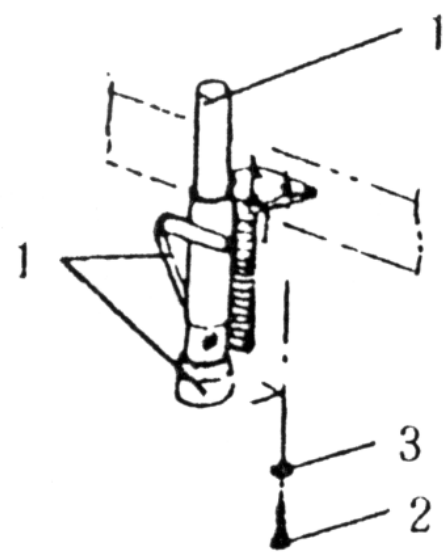

Fig. S-7 Parking Lock

<u>Item #</u>	<u>Description</u>	<u>Qty</u>	<u>L-150</u>
N1-8	Lowering Lever Assy	1	
-1	Screw	2	0216616
	Washer, spring	2	0980652
	Nut	2	0810611
-2	Pin	1	ND720020
	Pin, Spring	1	0460314
-3	Fixed Support	1	ND720010
-4	spring, tension	1	ND730000
-5	Screw, (stopper)	1	0216630
	Nut	1	0810611
-6	Lowering Lever	1	NA711012
-7	Sleeve, Connecting	1	ND740052
-8	Pin, Spring	2	0460420
-9	Crank	1	ND740031
-10	Washer	2	0910813
-11	Pin, "R"	2	0340808
-12	Spring, tension	1	ND760000
-13	connecting Rod ½	1	NA741061
	Nut	1	0810811
-14	Connecting Rod-3	1	ND741010
-15	Nut "U"	2	0810881

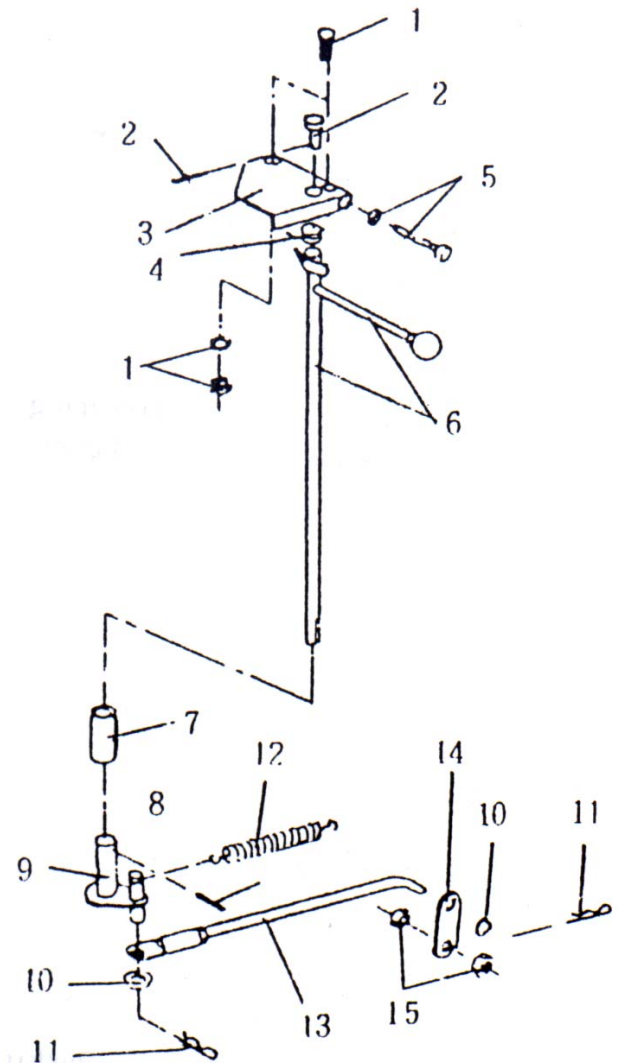

Fig. S-8 Lowering Lever Assembly

**marked parts are overlapping with jack assembly*

<u>Item No.</u>	<u>Description</u>	<u>Qty</u>	<u>L-150</u>
S-9	Jack Pedal Assembly	1	
-1	Pedal, Jack	1	NA430013
-2	Lever, Jack	1	NA401010
-3	Ring, Retaining "C"	1	0321601
-4	Shaft for Lever	1	NA410082
-5	Pin	1	NA410091
	Ring, retaining "E"	1	0320625
-6	Roller	1	ND41006

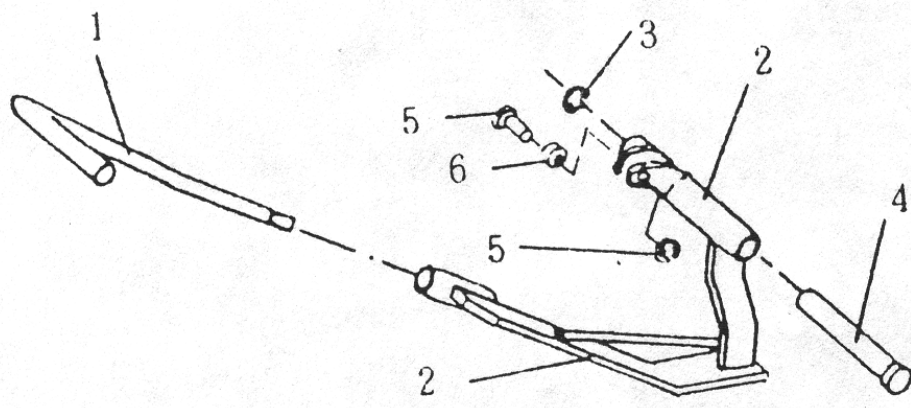
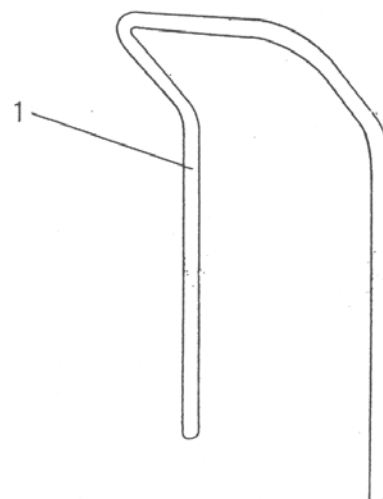
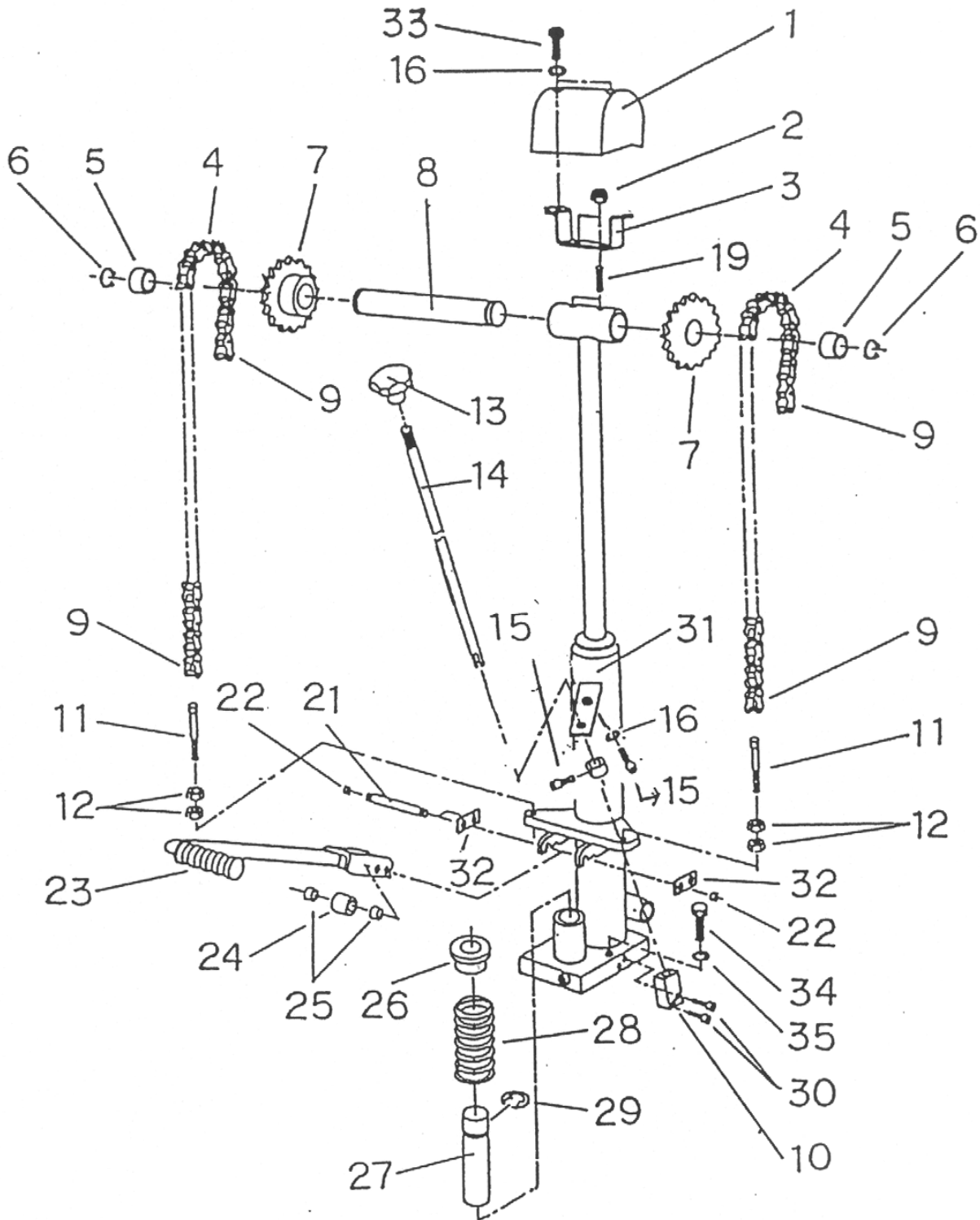

Fig. S-9
Jack Pedal Assembly

<u>No.</u>	<u>Name</u>	<u>M-500L</u>	<u>F-500L</u>	<u>F-500H</u>
1	Handle	NJ220011	NJ220011	NJ220011



M-500L, F-500L, F-500 H PARTS LIST



No.	Name	M-500L	F-500L	F-500H	Quantity
1	Chain Cover	NJ570000	NJ570000	NJ570000	1
2	Nut	0810612	0810612	0810612	2
3	Chain Cover Support	NJ510010	NJ510010	NJ510010	1
4	Roller Chain	NJ450030	NJ450030	NJ450030	2
5	Bush	12825DU	12825DU	12825DU	2
6	Ring Retaining C	0322801	0322801	0322801	2
7	Sprocket	NJ450010	NJ450010	NJ450010	2
8	Shaft	NJ500010	NJ500010	NJ500010	1
9	Offset Rink	NJ450040	NJ450040	NJ450040	2
10	Release Block	NM410000	NM410000	NM410000	1
11	Terminal	NJ490010	NJ490010	NJ490010	2
12	Nut	0811052	0811052	0811052	4
13	Release Handle	NM440040	NM440040	NM440040	1
14	Shaft	NM440010	NM440010	NM440010	1
15	Hexagon Socket Bolt	0190608	0190608	0190608	1
16	Spring Washer	0980652	0980652	0980652	2
19	Hexagon Socket Bolt	0212610-3D	0212610-3D	0212610-3D	2
21	Shaft	NJ430060	NJ430060	NJ430060	2
22	Ring Retaining C	0321001	0321001	0321001	4
23	Pedal Rubber	NJ540010	NJ540010	NJ540010	1
24	Roller	NJ430040	NJ430040	NJ430040	1
25	Bush	11010DU	11010DU	11010DU	2
26	Spring Box	NJ230010	NJ230010	NJ230010	1
27	Plunger	NJ220010	NJ220010	NJ220010	1
28	Plunger Spring	NJ240010	NJ240010	NJ240010	1
29	Ring Retaining E	0322405	0322405	0322405	1
30	Hexagon Socket Bolt	0190525	0190525	0190525	2
31	Long Jack	NM510001	NM510001	NM510001	1
32	Plate	NJ430050	NJ430050	NJ430050	2
33	Bolt	0214610	0214610	0214610	2
34	Hexagon Socket Bolt	0110830	0110830	0110830	1
35	Spring Washer	0980853	0980853	0980853	1

Wheel Caster

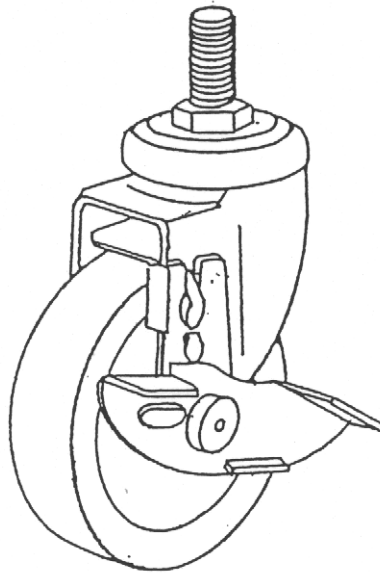

Caster Assy.

No.	Name	M-500L	F-500L	F-500H	Quantity
1	Rear swivel caster	413SA-UB150	413SA-UB150	413SA-UB150	2

M-500L Platform

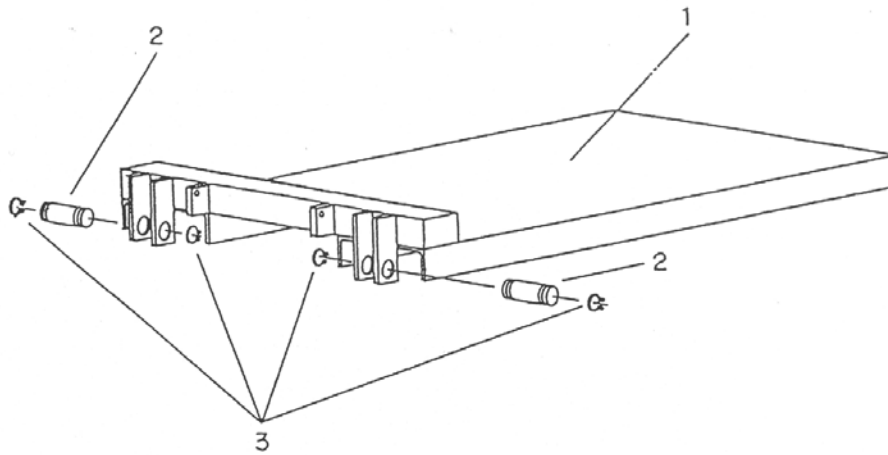

F-500L, F-500H Forks

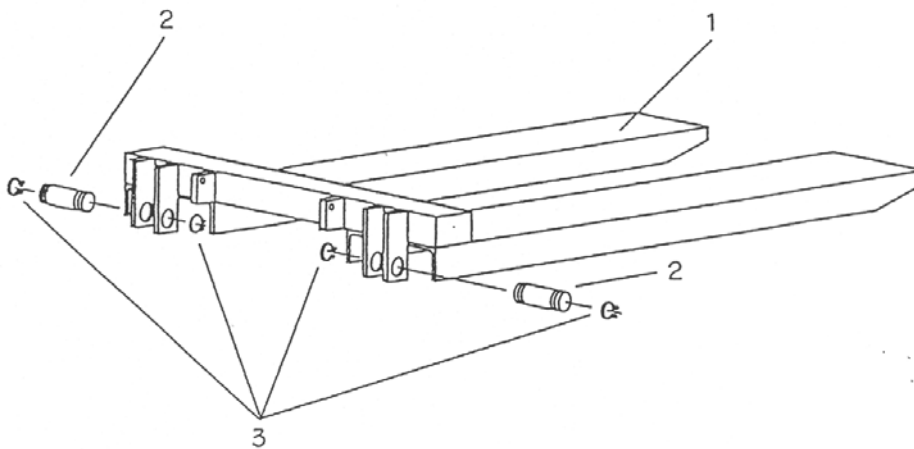

Platform/Forks Assy.

No.	Name	M-500L	F-500L	F-500H	Quantity
1	Platform	NJ210000	NK200000	NL200000	1
2	Shaft	NJ340010	NJ340010	NJ340010	2
3	Ring Retaining C	0322001	0322001	0322001	4

M-500L, F-500L, F-500H Scissor Assembly

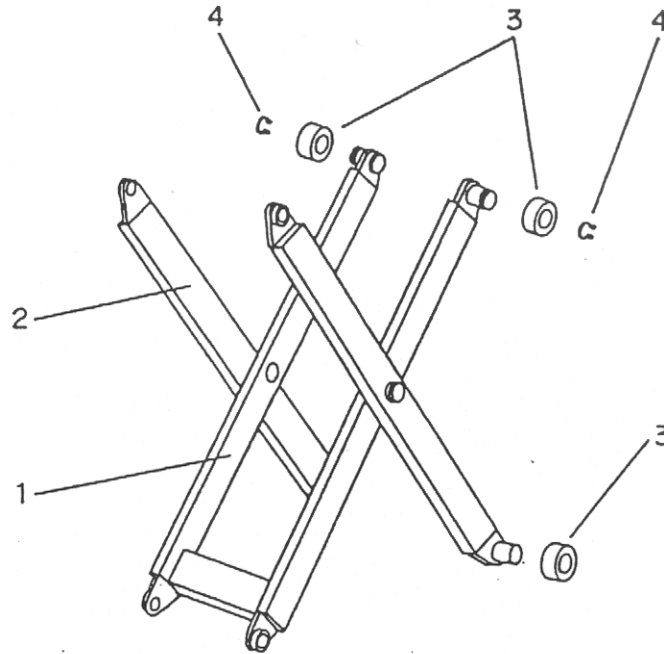

Scissor Assy.

No.	Name	M-500L	F-500L	F-500H	Quantity
1	Scissor (Inside)	NJ310000	NJ310000	NL310000	1
2	Scissor(Outside)	NJ320000	NJ320000	NL320000	1
3	Roller	NJ330010	NJ330010	NJ330010	4
4	Ring Retaining C	0322001	0322001	0322001	2

M-500L, F-500L, F-500H Frame

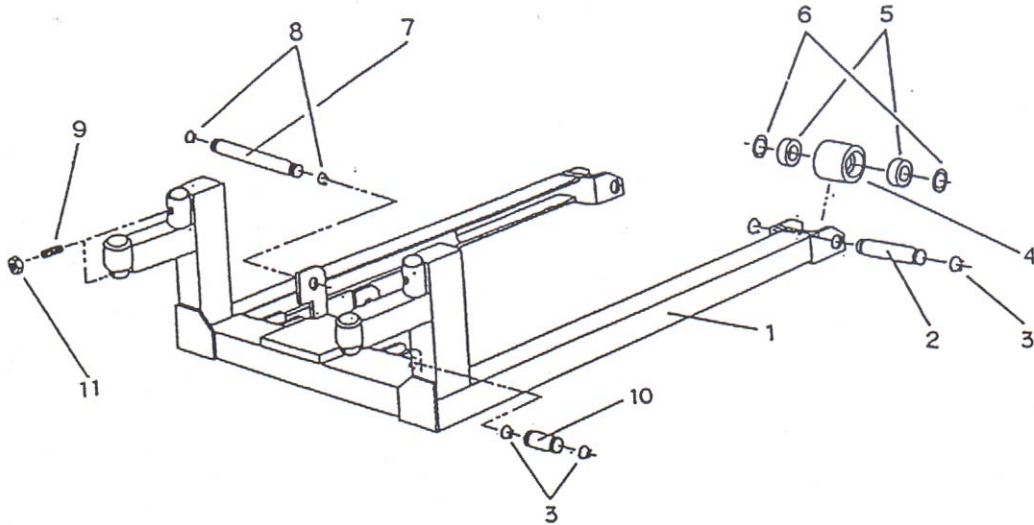

Frame Assy.

No.	Name	M-500L	F-500L	F-500H	Quantity
1	Frame	NJ100000	NJ100000	NL100000	1
2	Shaft	NJ410020	NJ410020	NJ410020	2
3	Ring Retaining C	0322001	0322001	0322001	8
4	Front Caster	NJ410010	NJ410010	NJ410010	2
5	Bearing	16204Z0	16204Z0	16204Z0	4
6	Washer	0912015	0912015	0912015	4
7	Shaft	NJ550010	NJ550010	NJ550010	1
8	Ring Retaining C	0321601	0321601	0321601	2
9	Hexagon Socket Bolt	0212812-3F	0212812-3F	0212812-3F	4
10	Shaft	NJ340010	NJ340010	NJ340010	2
11	Nut	0810812	0810812	0810812	4

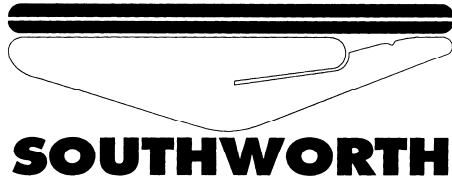

2 YEAR WARRANTY

Southworth Products Corp warrants this product to be free from defects in material or workmanship for a period of two (2) years of single shift usage from date of shipment, providing claim is made in writing within that time period. This warranty shall not cover modified designs for special applications, failure or defective operation caused by misuse, misapplication, negligence or accident, exceeding recommended capacities, failure to perform required maintenance or altering or repairing, unless alteration is authorized by Southworth Products Corp. Except as set forth herein, there are no other warranties, express or implied, including the warranties of merchantability and fitness for a particular purpose, all of which are hereby excluded.

Southworth Products Corp makes no warranty or representation with respect to the compliance of any product with state or local safety or product standard codes, and any failure to comply with such codes shall not be considered a defect of material or workmanship under this warranty. Southworth Products Corp shall not be liable for any direct or consequential damages arising out of such noncompliance.

Southworth Products Corp's obligation under this warranty is limited to the replacement or repair of defective components at its factory or another location at Southworth Products Corp's discretion. The Southworth Warranty is for product sold with in North America. For products shipped outside of North America the warranty will be for replacement of defective parts only. Labor is not included. This is buyer's sole remedy. Except as stated herein, Southworth Products Corp will not be liable for any loss, injury or damage to persons or property, nor for direct, indirect, or consequential damage of any kind, resulting from failure or defective operation of said product.

This warranty may be altered only in writing by Southworth Products Corp, Portland, Maine.

SOUTHWORTH PRODUCTS CORP
P.O. Box 1380, Portland, ME 04104-1380
Telephone: 800-743-1000 / 207-878-0700
Fax: 207-797-4734
www.SouthworthProducts.com

SOUTHWORTH

making work faster, safer, and easier

Southworth is the world class supplier of products designed to improve productivity and enhance safety. Our staff has over 400 years of engineering experience. If one of our standard products does not meet your needs, our engineers can custom design equipment specifically suited to your material handling application.



Spring PalletPal Load Leveler



Lift with Flush Mount Turntable



Portable Container Tilters



Dock Lifts



Roll on Level Loaders



Portable Lifts



Stack-n-Go Powered Stacker



**Floor Height Lifts
Roll-E**

**Floor to
Mezzanine Lifts**



Pallet Rotators



For more information, contact Southworth Products

Telephone (800) 743-1000 Fax (207) 797-4734

Email: salesinfo@SouthworthProducts.com