

SOUTHWORTH

Owner's Manual

Dandy Leveler **DLV-150 & DLV-500**



Model # _____

Serial # _____

Southworth Products Corp
P.O. Box 1380/Portland, Maine 04104-1380
Phone 800-743-1000 • FAX 207-797-4734

www.southworthproducts.com
service@southworthproducts.com

Please note: This manual was current at the time of printing. To obtain the latest, most updated version, please contact Southworth's Customer Service Department or go to our website: www.SouthworthProducts.com, under E-Parts & Service you will find a complete list of current owner's manuals to print.

TABLE OF CONTENTS

RESPONSIBILITY OF OWNERS AND USERS	4
SAFETY ALERT SYMBOLS AND SIGNAL WORDS.....	5
SAFETY	6
SPECIFICATIONS.....	7
USING THE DANDY LEVELER	7-8
ASSEMBLY	8
PARTS LISTS.....	9-14
ORDERING REPLACEMENT PARTS.....	15
WARRANTY	16

Responsibility of Owners and Users

Inspection and Maintenance

The device shall be inspected and maintained in proper working order in accordance with Southworth's owner's manual.

Removal from Service

Any device not in safe operating condition such as, but not limited to, excessive leakage, missing rollers, pins, or fasteners, any bent or cracked structural members, cut or frayed electric, hydraulic, or pneumatic lines, damaged or malfunctioning controls or safety devices, etc. shall be removed from service until it is repaired to the original manufacturer's standards.

Deflection

It is the responsibility of the user/purchaser to advise the manufacturer where deflection may be critical to the application.

Repairs

All repairs shall be made by qualified personnel in conformance with Southworth's instructions.

Operators

Only trained personnel and authorized personnel shall be permitted to operate the equipment.

Before Operation

Before using the device, the operator shall have:

- Read and/or had explained, and understood, the manufacturer's operating instructions and safety rules.
- Inspected the device for proper operation and condition. Any suspect item shall be carefully examined and a determination made by a qualified person as to whether it constitutes a hazard. All items not in conformance with Southworth's specification shall be corrected before further use of the equipment.

During Operation

The device shall only be used in accordance with this owner's manual.

- Do not overload.
- Ensure that all safety devices are operational and in place.

Modifications or Alterations

Modifications or alterations to any Southworth industrial positioning equipment shall be made only with written permission from Southworth.

SAFETY ALERT SYMBOLS AND SIGNAL WORDS

The safety of all persons operating, maintaining, repairing, or in the vicinity of this equipment is of paramount concern. This is a powerful machine with moving parts, and is capable of causing personal injury if proper precautions are not taken. Therefore, throughout this manual, certain hazards have been identified which may occur in the use of the machine, and there are appropriate instructions or precautions which should be taken to avoid these hazards. In some cases, there are consequences which may occur if instructions or precautions are not followed. Below are the symbols and signal words along with their definitions referenced from ANSI Z535.4 - Product Safety Signs and Labels.

Safety Alert Symbols

These are the safety alert symbols. They are used to alert you to potential physical injury hazards. Obey all safety messages that follow this symbol to avoid possible injury or death.



For use with **DANGER** signal word
(Red Background)



For use with **WARNING** signal word
(Orange Background)



For use with **CAUTION** signal word
(Yellow Background)

Signal Words

The meaning of different signal words as defined by ANSI Standard Z535.4 indicates the relative seriousness of the hazardous situation.



(Red Background)

DANGER indicates a hazardous situation which, if not avoided, will result in death or serious injury.



(Orange Background)

WARNING indicates a hazardous situation which, if not avoided, could result in death or serious injury.



(Yellow Background)

CAUTION, used with the safety alert symbol, indicates a hazardous situation which, if not avoided, could result in minor or moderate injury.



(Blue Background)

NOTICE is used to address practices not related to personal injury.



(Green Background)

SAFETY INSTRUCTIONS (or equivalent) signs indicate safety-related instructions or procedures.

SAFETY

Warning: Failure to obey the instruction and safety rules in this manual and the DANDY LIFT Operator's Manual may result in death or serious injury.

Many of the hazards identified in the operating instruction manual are also safety hazards when performed.

Do Not Perform Maintenance Unless:

You are trained and qualified to perform maintenance on this machine.

You read, understand and obey:

- Manufacture's instructions and safety rules
- Employer's safety rules and worksite regulations
- Applicable governmental regulations

You have the appropriate tools, lifting equipment and a suitable workshop.

WARNING

While performing maintenance do not work on a raised lift. Lay the lift on its side when working on the Dandy Leveler

DANGER

Immediate hazard which will result in severe personal injury or death.

WARNING

Hazardous or unsafe practice which could result in severe personal injury or death.

CAUTION

Hazardous or unsafe practice which could result in minor personal injury or property damage.

Please read and follow the instructions in this manual, including all safety instructions and precautions, carefully and completely.

INSTRUCTION MANUAL

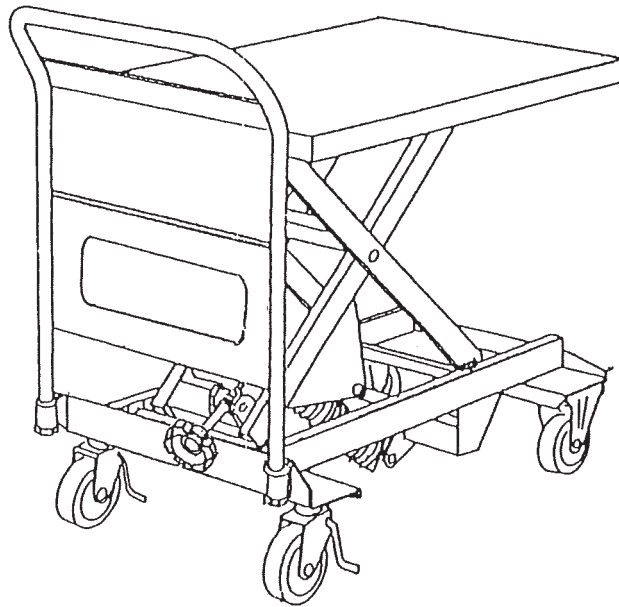

The Dandy Leveler is a transporter and load leveler which uses a simple spring mechanism to adjust the height of a load. Because of its simple durable structure, it requires very little maintenance. Refer to this instruction manual before assembling and using the Dandy Leveler.

SPECIFICATIONS

	DLV-150	DLV-500
Max Load (kg)	150	500
Load Weight Setting	50 : 75 : 100 : 150	100 : 200 : 300 : 400 : 500
Max Table Height (mm)	665	800
Min Table Height (mm)	275	380
Table Size (mm)	710 x 450	910 x 600
Casters (mm)	100 (two swivel casters on rear, each equipped with stopper)	125 (two swivel casters on rear, each equipped with stopper)
Tare Weight (kg)	36	86

USING THE DANDY LEVELER

1. Distribute a load evenly on the table when loading or unloading.
2. Apply the parking brake when using the Dandy Leveler in a stationary position. If necessary take other measures to make the frame stationary.
3. When transporting a load on the Dandy Leveler, pay adequate attention to condition of

the floor. The clearance between the floor and the bottom of the frame is 40mm for both the DLV-150 and DLV-500.

4. The Dandy Leveler is maintenance free; however, it should be lubricated when the unit creaks due to lack of oil. Also, when inspecting the unit or marking load weight adjustments, apply the roller stopper.

ASSEMBLY

The Dandy Leveler is shipped with the spring and handle detached, to assemble the unit, follow the instructions below.

1. Assembling the spring

- Apply the caster stoppers on the rear wheels.
- Lift up the table by both ends and removed the Lock pin on the right side of the frame.
- Holding up the table, place the Lock pin in the stopper hole.

This assembly should be done by two people.

CAUTION :

- The Lock pin functions as a stopper when it is placed on the outside of the roller. The stopper has no function on the inside of the roller.
- When assembling the unit, be sure to place the Lock pin on the outside of the roller to prevent accidents.

2. Assembling the Handle

Remove the nut and spring washer of the handle and place the handle in the fastening units on the rear of the frame (the caster stopper side). Put on the spring washer and fasten with the nut.

DLV-150		DLV-500	
Caster Brake		Caster Brake	
Apply	Release	Apply	Release

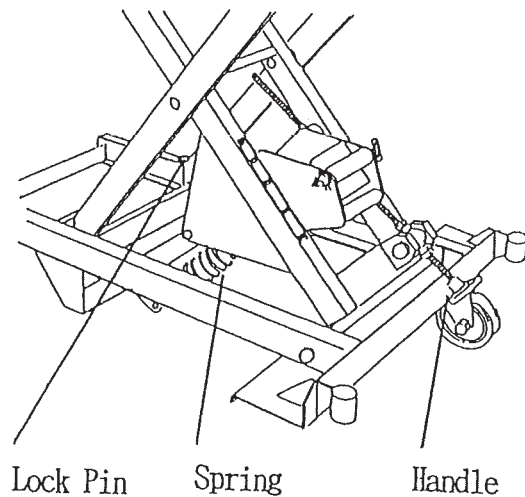
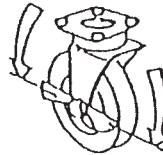

SELECTING THE LOAD WEIGHT ADJUSTMENT BY THE HANDLE

The maximum load weight for the Dandy Levelers are 150kg for the DLV-150 and 500kg for the DLV-500. The Leveler can be adjust to the expected load weight so that it functions at its best response to the load weight you use. Asjust the spring by placing the handle to the maximum load weight you will use.

CAUTION :

When making adjustment for a load weight, empty the table and be sure to apply the caster stopper so that the Leveler does not move.

PLATFORM PARTS LIST

DLV-150

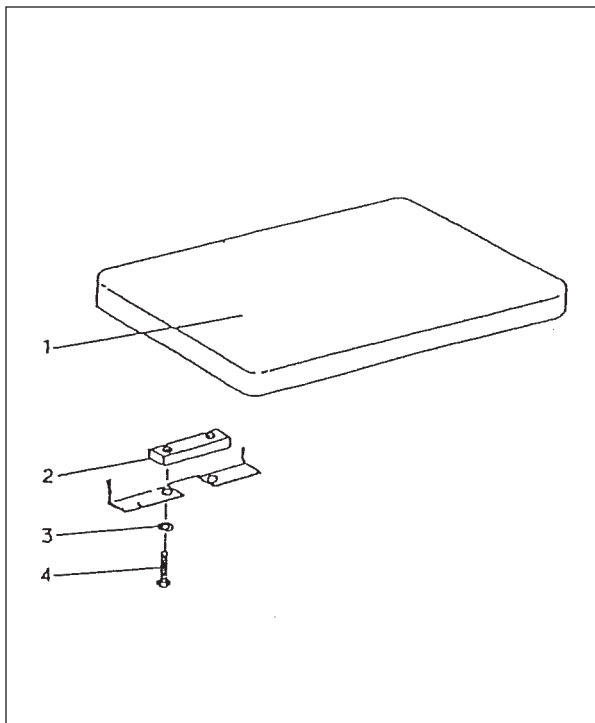

DLV-500

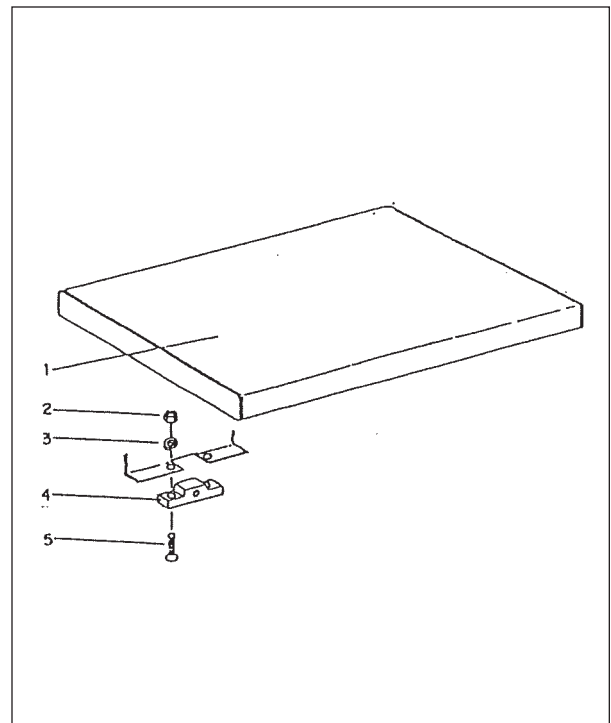

No.		DLV-150		DLV-500	
1	Platform	NH200010	1	N1200010	1
2	Roller Stopper 2	NH210010	2	NH210010	2
3	Spring Washer	0980853	4	0980853	4
4	Screw	0218820	4	0218820	4

SCISSOR PARTS LIST

DLV-150

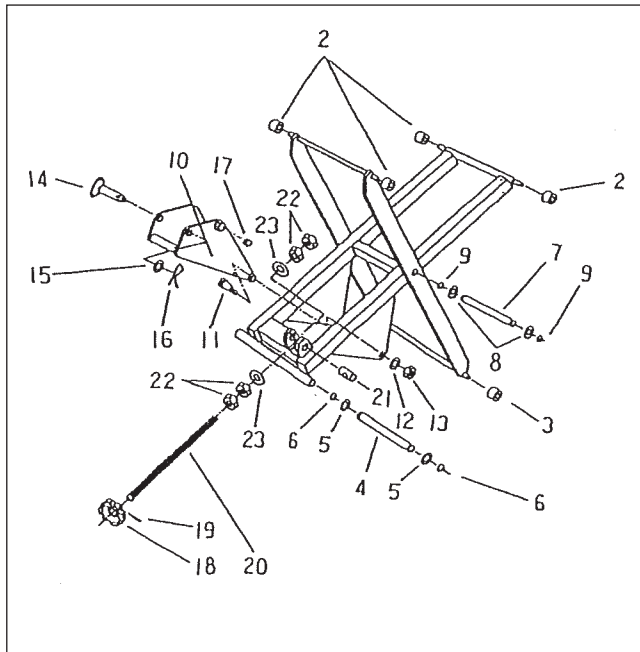

DLV-500

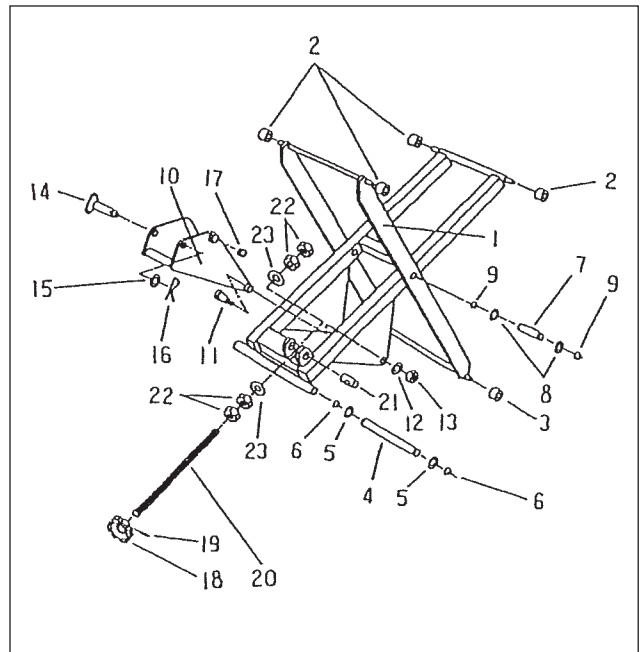

No.	Description	DLV-150		DLV-500	
1	Scissor	NH300000	1	NI300033	1
2	Roller (upper)	NA351002	4	ND351001	4
3	Roller (lower)	NA361002	2	ND361001	2
4	Shaft	NH400020	1	NI400020	1
5	Washer	0911616	2	0912017	2
6	Ring Retaining C	0321601	2	0322001	2
7	Center Shaft	NH400010	1	NI400010	2
8	Washer	0911215	2	0911616	4
9	Ring Retaining C	0321201	2	0321601	4
10	Lever Box	NH330000	1	NI330000	1
11	Pin Pivot	NH340050	2	NH340050	2
12	Washer	0911616	2	0911616	2
13	U Nut	0811282-03	2	0811282-03	2
14	Spring Shaft Pin	NH410010	1	NI410010	1
15	Washer	0911215	1	0911616	1
16	Pin R	0341212	1	0341616	1
17	Support Nut (lower)	NH340010	1	NI340010	1
18	Handle Knob	NH340061	1	NI340061	1
19	Spring Ping	0410820	1	0410820	1
20	Screw	NH340030	-	NI340030	1
21	Support Nut (upper)	NH340020	1	NI340020	1
22	Nut	0811212-02	4	0811612-02	4
23	Washer	0911215	2	0911616	2

FRAME PARTS LIST

DLV-150

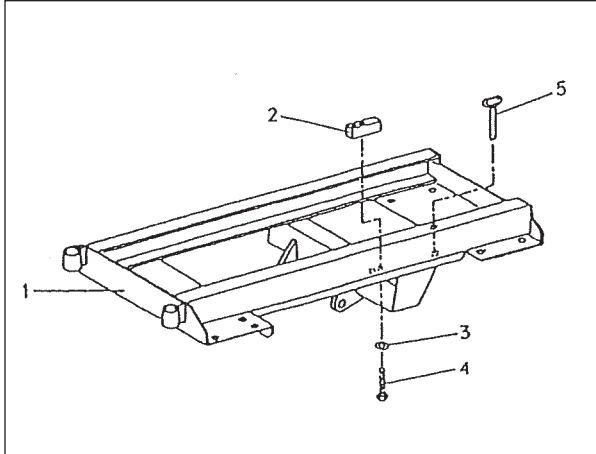

DLV-500

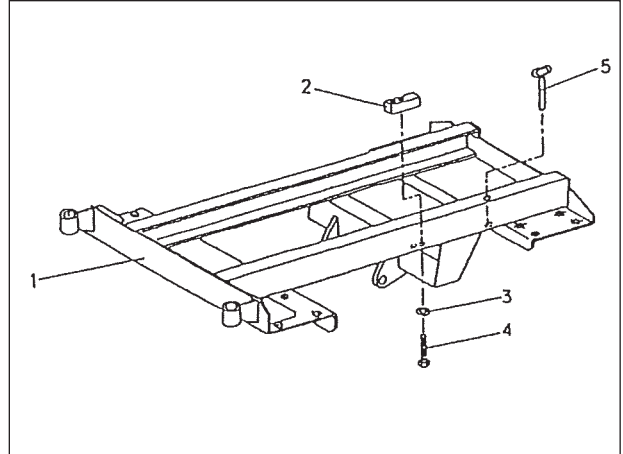

No.	Description	DLV-150		DLV-500	
1	Frame	NH100000	1	NI100000	1
2	Roller Stopper	NH370010	1	NH370010	1
3	Spring Washer	0980853	2	0980853	2
4	Screw	0810812-01	2	0810812-01	2
5	Lock Pin	NH380000	1	NI380000	1

HANDLE PARTS LIST

DLV-150

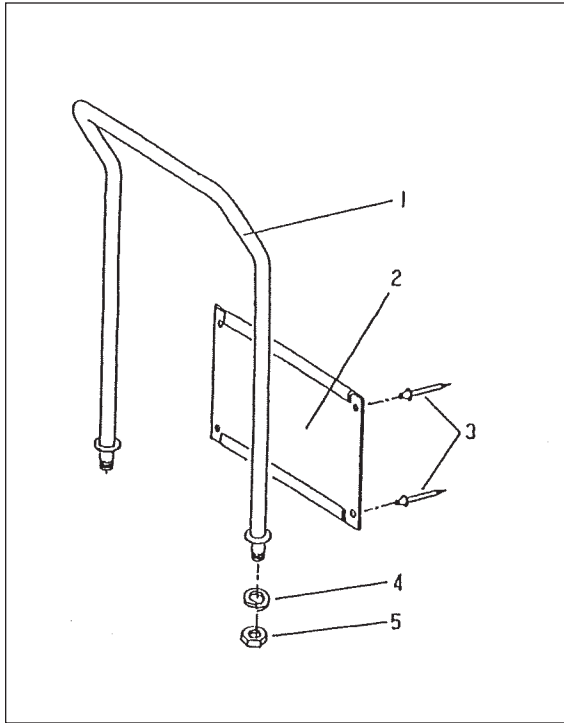

DLV-500

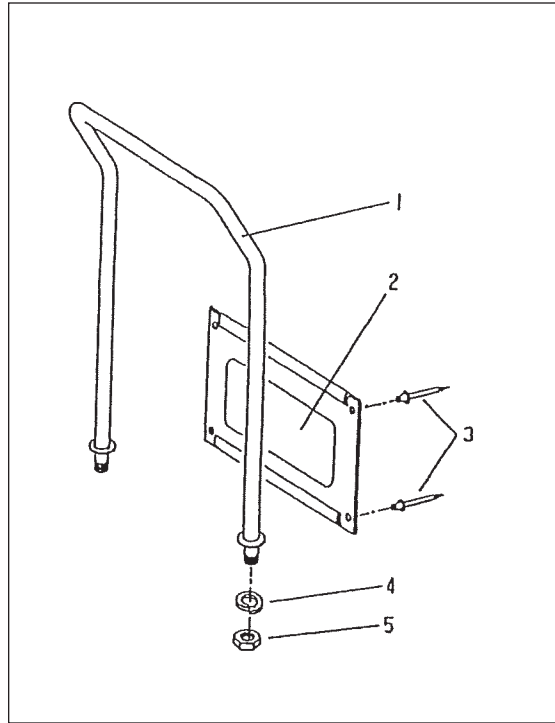

No.	Description	DLV-150		DLV-500	
1	Handle	NS220010	1	ND220011	1
2	Name Plate	NH230010	1	NI230010	1
3	Pivet	NH910060	4	NI910060	4
4	Spring Washer	0982057	2	0982057	2
5	Nut	0812011	2	0812011	2

SPRING UNIT PARTS LIST

DLV-150

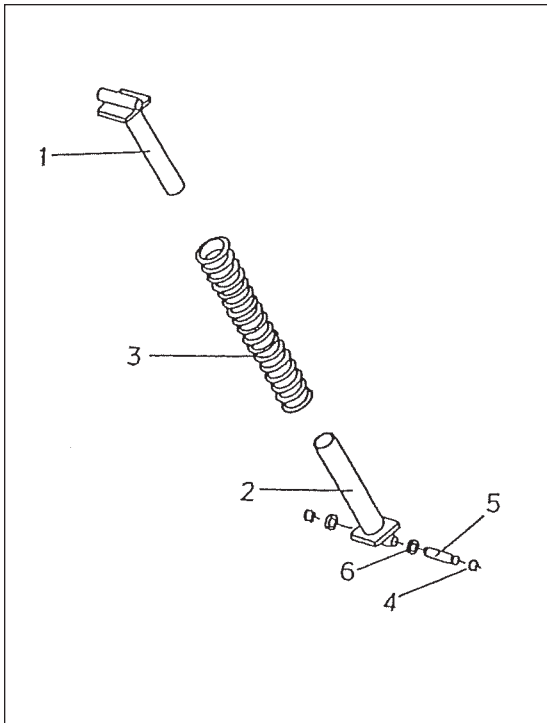

DLV-500

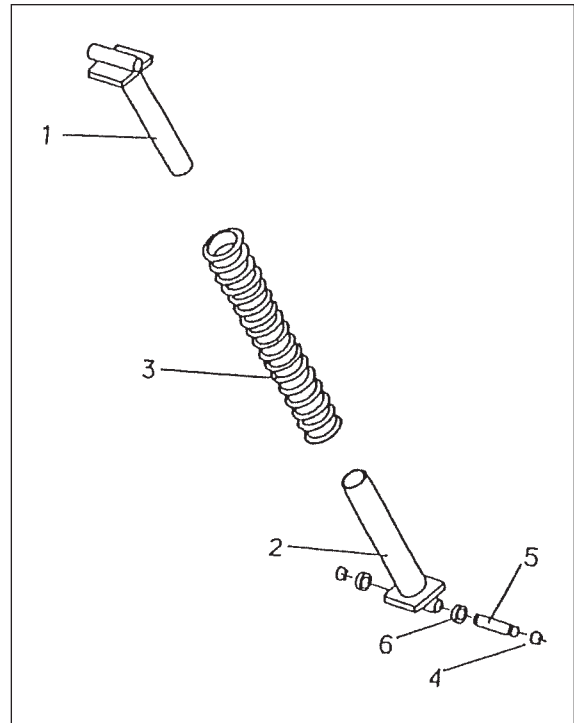

No.	Description	DLV-150		DLV-500	
1	Spring Holder (upper)	NH740010	1	NI711010	1
2	Spring Holder (lower)	NH730010	1	NI712010	1
3	Spring	NH720010	1	NI713010	1
4	Ring Retaining C	0321201	2	0321601	2
5	Spring Shaft	NH410010	1	NH410010	1
6	Needle Bearing	1121200	4	1161600	4

CASTER PARTS LIST

DLV-150

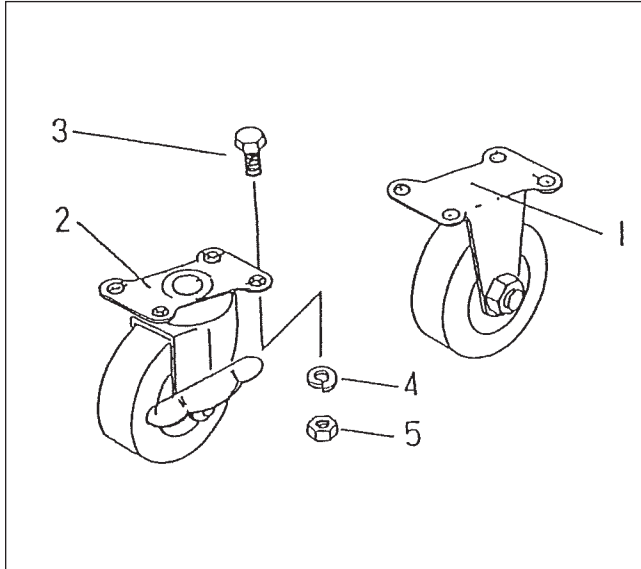

DLV-500

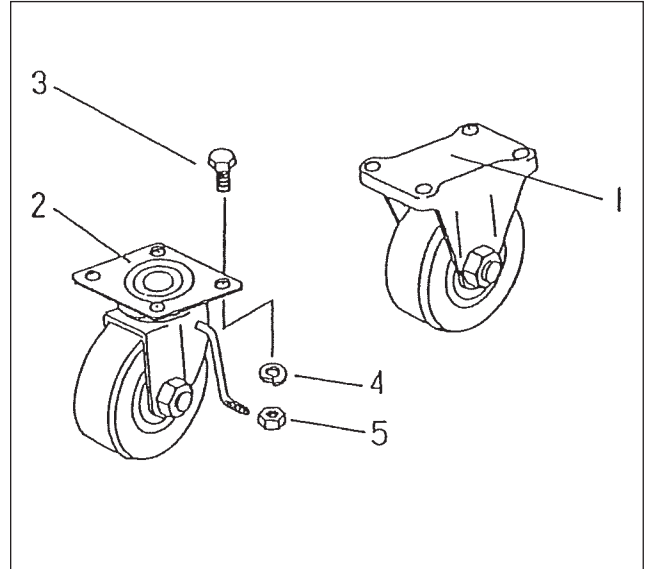

No.	Description	DLV-150		DLV-500	
1	Front Caster	K-SKK-R100S	2	38-WK-130R	2
2	Rear Caster	J-SKK-R100S	2	38-WJS-130R	2
3	Screw	0110814	16	0111020	16
4	Spring Washer	0980813	16	0911014	16
5	Nut	0810812	16	0811012	16

Ordering Replacement Parts

Southworth has carefully chosen the components in your unit to be the best available for the purpose. Replacement parts should be identical to the original equipment. **Southworth will not be responsible for equipment failures resulting from the use of incorrect replacement parts or from unauthorized modifications to the machine.**

Southworth can supply all replacement parts for your Southworth lift. We have identified key replacement parts for your lift. With your order, please include the model number and the serial number of the unit. You will find these numbers on the name plate.

To order replacement parts, please call the Parts Department at (207) 878-0700. Parts are shipped subject to the following terms:

- FOB factory.
- Returns only with the approval of our parts department.
- Payment net 30 days (except parts covered by warranty).
- Freight collect (except parts covered by warranty).
- The warranty for repair parts is 30 days from date of shipment.

Parts replaced under warranty are on a "charge-credit" basis. We will invoice you when we ship the replacement part, then credit you when you return the worn or damaged part, and we verify that it is covered by our warranty. Labor is not covered under warranty for Parts orders.

Parts Department
Southworth Products Corp
P.O. Box 1380
Portland, ME 04104-1380
Telephone: (207) 878-0700
FAX: (207) 797-4734
repairparts@SouthworthProducts.com

2 YEAR WARRANTY

Southworth Products Corp warrants this product to be free from defects in material or workmanship for a period of **2 years** of single shift usage from date of shipment, providing claim is made in writing within that time period. This warranty shall not cover modified designs for special applications, failure or defective operation caused by misuse, misapplication, negligence or accident, exceeding recommended capacities, failure to perform required maintenance or altering or repairing, unless alteration is authorized by Southworth Products Corp. Except as set forth herein, there are no other warranties, express or implied, including the warranties of merchantability and fitness for a particular purpose, all of which are hereby excluded.

All **batteries have a 90 day parts and labor** warranty, this warranty covers any defects in material and workmanship from the date of shipment.

Southworth Products Corp makes no warranty or representation with respect to the compliance of any product with state or local safety or product standard codes, and any failure to comply with such codes shall not be considered a defect of material or workmanship under this warranty. Southworth Products Corp shall not be liable for any direct or consequential damages arising out of such noncompliance.

Southworth Products Corp's obligation under this warranty is limited to the replacement or repair of defective components at its factory or another location at Southworth Products Corp's discretion. The Southworth Warranty is for product sold with in North America. For products shipped outside of North America the warranty will be for replacement of defective parts only. Labor is not included. This is buyer's sole remedy. Except as stated herein, Southworth Products Corp will not be liable for any loss, injury or damage to persons or property, nor for direct, indirect, or consequential damage of any kind, resulting from failure or defective operation of said product.

This warranty may be altered only in writing by Southworth Products Corp, Portland, Maine.

SOUTHWORTH PRODUCTS CORP

P.O. Box 1380, Portland, ME 04104-1380

Telephone: (800) 743-1000 • (207) 878-0700

Fax: (207) 797-4734

www.SouthworthProducts.com

SOUTHWORTH

making work faster, safer, and easier

Southworth is the world class supplier of products designed to improve productivity and enhance safety. Our staff has over 400 years of engineering experience. If one of our standard products does not meet your needs, our engineers can custom design equipment specifically suited to your material handling application.



Spring PalletPal Load Leveler



Lift with Flush Mount Turntable



Portable Container Tilters



Dock Lifts



Roll on Level Loaders



Portable Lifts



Stack-n-Go Powered Stacker



**Floor Height Lifts
Roll-E**

**Floor to
Mezzanine Lifts**



Pallet Rotators



For more information, contact Southworth Products

Telephone (800) 743-1000 Fax (207) 797-4734

Email: salesinfo@SouthworthProducts.com