

SOUTHWORTH

Owner's Manual SSLS2.5-37 & SSLS4-27 Series Lift Tables



SOUTHWORTH PRODUCTS CORP

PO Box 1380, Portland, ME 04104-1380

Telephone: 1-800-743-1000 or 207-878-0700

Fax: 207-797-4734

www.SouthworthProducts.com

service@SouthworthProducts.com

July 2015

Please note: This manual was current at the time of printing.
To obtain the latest, most updated version, please contact Southworth's Customer Service Department or go to our website:
www.SouthworthProducts.com, under Parts & Service
you will find a complete list of current
owner's manuals to print.

Contents

INTRODUCTION	Page 4
RESPONSIBILITY OF OWNERS AND USERS	5
SAFETY ALERT SYMBOLS AND SIGNAL WORDS.....	6
INCREASED PRODUCTIVITY	7
SAFETY FIRST	7
Safety Features	8
LOCK OUT PROCEDURE	8
INSTALLATION	8
OPERATION.....	8
LIFT SPECIFICATIONS	9
TROUBLESHOOTING	10
ORDERING REPLACEMENT PARTS.....	15
WARRANTY	16

List of Figures

Figure 1. Power Unit Assembly	11
Figure 2. Hydraulic Schematic	12
Figure 3. Electrical Schematic - Single Phase	13
Figure 4. Electrical Schematic - Three Phase.....	14

INTRODUCTION

This manual contains information to acquaint you with the safe and proper installation, use and upkeep of the machine. You should ensure that this manual is available to personnel working with the machine and require its use by these personnel.

In the interest of safety, please read this entire manual carefully and be familiar with its contents before you install, use or service the machine. If you have any questions about any instructions in this manual, please contact your dealer or Southworth Products Corp.

Southworth's product warranty is provided in the back of this manual. This instruction manual is not intended to be or to create any other warranty, expressed or implied, including any implied warranty of merchantability or fitness for a particular purpose, all of which are hereby expressly excluded.

As set forth more specifically in the product warranty, Southworth's obligation under that warranty is limited to the repair or replacement of defective components, which shall be the buyer's sole remedy. Southworth shall not be liable for any loss, injury or damage to persons or property, nor for any direct, indirect or consequential damage of any kind resulting from the lift table.

Responsibility of Owners and Users

Inspection and Maintenance

The device shall be inspected and maintained in proper working order in accordance with Southworth's owner's manual.

Removal from Service

Any device not in safe operating condition such as, but not limited to, excessive leakage, missing rollers, pins, or fasteners, any bent or cracked structural members, cut or frayed electric, hydraulic, or pneumatic lines, damaged or malfunctioning controls or safety devices, etc. shall be removed from service until it is repaired to the original manufacturer's standards.

Deflection

It is the responsibility of the user/purchaser to advise the manufacturer where deflection may be critical to the application.

Repairs

All repairs shall be made by qualified personnel in conformance with Southworth's instructions.

Operators

Only trained personnel and authorized personnel shall be permitted to operate the lift.

Before Operation

Before using the device, the operator shall have:

- Read and/or had explained, and understood, the manufacturer's operating instructions and safety rules.
- Inspected the device for proper operation and condition. Any suspect item shall be carefully examined and a determination made by a qualified person as to whether it constitutes a hazard. All items not in conformance with Southworth's specification shall be corrected before further use of the equipment.

During Operation

The device shall only be used in accordance with this owner's manual.

- Do not overload.
- Ensure that all safety devices are operational and in place.

Modifications or Alterations

Modifications or alterations to any Southworth industrial positioning equipment shall be made only with written permission from Southworth.

SAFETY ALERT SYMBOLS AND SIGNAL WORDS

The safety of all persons operating, maintaining, repairing, or in the vicinity of this equipment is of paramount concern. This is a powerful machine with moving parts, and is capable of causing personal injury if proper precautions are not taken. Therefore, throughout this manual, certain hazards have been identified which may occur in the use of the machine, and there are appropriate instructions or precautions which should be taken to avoid these hazards. In some cases, there are consequences which may occur if instructions or precautions are not followed. Below are the symbols and signal words along with their definitions referenced from ANSI Z535.4 - Product Safety Signs and Labels.

Safety Alert Symbols

These are the safety alert symbols. They are used to alert you to potential physical injury hazards. Obey all safety messages that follow this symbol to avoid possible injury or death.



For use with **DANGER** signal word
(Red Background)



For use with **WARNING** signal word
(Orange Background)



For use with **CAUTION** signal word
(Yellow Background)

Signal Words

The meaning of different signal words as defined by ANSI Standard Z535.4 indicates the relative seriousness of the hazardous situation.



(Red Background)

DANGER indicates a hazardous situation which, if not avoided, will result in death or serious injury.



(Orange Background)

WARNING indicates a hazardous situation which, if not avoided, could result in death or serious injury.



(Yellow Background)

CAUTION, used with the safety alert symbol, indicates a hazardous situation which, if not avoided, could result in minor or moderate injury.



(Blue Background)

NOTICE is used to address practices not related to personal injury.



(Green Background)

SAFETY INSTRUCTIONS (or equivalent) signs indicate safety-related instructions or procedures.

INCREASED PRODUCTIVITY

This sanitary lift can be used to raise and lower products vertically. This could reduce loss time injuries due to back strain and cumulative trauma illness. This reduction could increase job efficiency, productivity and work quality.

SAFETY FIRST

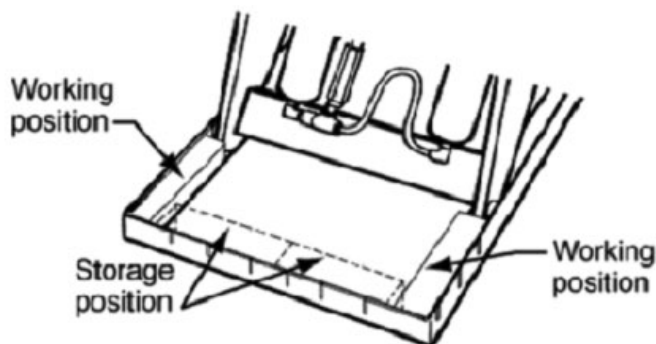

⚠️ WARNING

ONLY AUTHORIZED PERSONNEL SHOULD PERFORM INSPECTION OR MAINTENANCE AND SERVICE PROCEDURES. UNAUTHORIZED PERSONNEL ATTEMPTING THESE PROCEDURES DO SO AT THE RISK OF SEVERE INJURY OR DEATH.

⚠️ DANGER

FAILURE TO PROPERLY ADHERE TO LIFT BLOCKING PROCEDURES IS TO RISK THE SUDDEN AND UNCONTROLLED DESCENT OF THE LIFT DURING MAINTENANCE OR INSPECTION. A FALLING LIFT CAN CAUSE SEVERE INJURY OR DEATH.

This procedure describes the only factory-approved method of working under a lift. Follow these instructions **EVERY** time you plan to reach or crawl beneath the lift to perform service or maintenance – no matter how momentary that might be.

NOTE: IF THE FACTORY-PROVIDED MAINTENANCE DEVICE IS DAMAGED OR MISSING, STOP IMMEDIATELY AND CONSULT THE FACTORY FOR ASSISTANCE. THE MANUFACTURER IS NOT LIABLE FOR YOUR FAILURE TO USE THE APPROVED MAINTENANCE DEVICE(S) AND PROCEDURES THAT HAVE BEEN PROVIDED.

1. Any load must be removed from the lift prior to engaging the maintenance device(s). These devices are designed to support an unloaded lift only. Failure to remove the load from the lift prior to blocking could cause the failure of the maintenance device(s) and allow the lift to fall unexpectedly. This can result in personal injury or death, or permanent damage to the maintenance device(s) and/or the lift.
2. Raise the lift to its fully raised position. If you do not, the maintenance device(s) may not be able to be placed properly in its/their designed blocking position.
3. Remove the maintenance device(s) from its/their storage location and place it/them into the engaged position as shown in Figure 1. (Note: further information may be useful here to provide additional instructions as to the location and method of storage and engaged positions).
4. Lower the lift until it makes complete contact with the maintenance device(s). Re-check to ensure that all provided devices are fully and securely engaged. If the device(s) is/are not fully engaged the lift could fall unexpectedly, resulting in permanent damage to the device(s) or the lift.

⚠️ DANGER

IF FOR ANY REASON YOU ARE UNABLE TO LOWER THE LIFT COMPLETELY ONTO THE MAINTENANCE DEVICE(S), STOP IMMEDIATELY AND CONSULT THE FACTORY. FAILURE TO PROPERLY USE THE FACTORY APPROVED MAINTENANCE DEVICE(S) COULD RESULT IN SEVERE INJURY OR DEATH.

5. (For single-acting hydraulic, and pneumatic lifts) Once the maintenance device(s) is/are properly and securely engaged, continue to press the down button, valve or switch for an additional 5-10 seconds to relieve all pressure in the operating system (add more specifics here as required for pneumatic lifts).

⚠️ WARNING

FAILURE TO RELIEVE OPERATING SYSTEM PRESSURE COULD RESULT IN THE SUDDEN AND UNEXPECTED RELEASE OF HIGH PRESSURE FLUIDS (OR AIR) DURING MAINTENANCE AND/OR REPAIR OF THE LIFT AND RESULT IN SEVERE INJURY OR DEATH.

OPERATING AND MAINTENANCE MANUAL

6. Follow OSHA electrical lock-out/tag-out procedures. Disconnect and tag all electrical and/or other power sources to prevent an unplanned or unexpected actuation of the lift.
7. Once inspection or work is complete, reverse the performance of the steps above to raise the lift off the maintenance device(s) and place the device(s) back into its/their designated storage position(s).

⚠ DANGER

HIGH VOLTAGE ! – DISCONNECT AND/OR LOCK OUT THE ELECTRICAL SUPPLY TO THE POWER UNIT PRIOR TO ANY INSTALLATION OR MAINTENANCE BEING PERFORMED.

⚠ WARNING

FAILURE TO FOLLOW THE INSTRUCTIONS IN THIS MANUAL CAN CAUSE PERSONAL INJURY AND/OR PROPERTY DAMAGE!

Carefully read all safety messages in this manual and all warning stickers on your sanitary lift. Keep ALL safety signs and labels in good condition and replace those that are damaged.

⚠ WARNING

WATCH HANDS AND FINGERS! KEEP EXTREMITIES AWAY FROM SCISSORS ARMS WHEN MACHINE IS IN OPERATION!

Safety Features:

- Continuous-touch up/down footswitch control.

LOCK OUT PROCEDURE

When cleaning, maintaining or disassembly is required, the lift should be completely powerless. The main power to the lift controls and power unit must be disconnected and locked out.

INSTALLATION

1. After locating the unit in the work area, anchor the base firmly to a level floor before operating unit.
 - When leveling the unit, shims may be used to obtain a level position. South-

worth Products recommends using a grout to provide a solid surface underneath the support angle base. The channel must have a solid base to support the wheels or damage/failure to the support could result.

- There are four anchor points on the lift. These are located on the inside base of the lift. Use a corrosion resistant 3/4" bolt in all four points for proper anchoring.
 - To access the four inside anchor points, the lift must be raised. See the electrical diagram (page 10) for proper wiring.
2. Plug the power cable into a 110V AC, properly grounded outlet with sufficient amperage capacity to run a 1 HP electric motor.
 3. Check hydraulic fluid level in reservoir. The level should be approximately 1 1/2 " below the fill hole.
 4. Grease each of the four grease points on the lift. They are located on the four cylinder areas by the middle of the scissors arms. These grease points have been greased at our factory.
 5. The four grease points should be greased on a regular basis. Depending on your type of operation and wash down procedure, Southworth Products recommends you grease these points on a weekly basis.

OPERATION

⚠ WARNING

KEEP EXTREMITIES AWAY FROM ALL MOVING PARTS. UNDER NO CIRCUMSTANCES SHOULD ANY ONE WALK UNDER OR HAVE ANY PART OF THEIR BODY UNDER THIS LIFT!

NOTE: LOADS MUST NOT EXCEED 2,500 LBS. FOR THE SSLS2.5-27 MODEL LIFT AND 4,000 LBS. FOR THE SSLS4-27 MODEL LIFT.

Once the unit has been properly set up per the SET UP instructions, try the unit empty first to test the operation to be sure it is working properly. Then test the unit with a load. Keep all loads properly centered and balanced as much as possible.

SUGGESTED PREVENTATIVE MAINTENANCE SCHEDULE

Inspect the following weekly:

Leg rollers, center pivot pins and bushings, leg hinge pins and bushings for evidence of wear, loose bolts or broken cotter pins or keepers. Repair or replace as required.

Inspect the following Monthly:

- Apply oil or WD-40 to non-greased pivot points or rollers describes above (if applicable).
- Check the appearance of the hydraulic fluid.

Inspect the following every six months or 500 hours of operation:

- Check all the hydraulic fittings and hoses and repair the connections as necessary.
- Inspect cylinder return line and rod. Appearance of considerable fluid in the vent lines indicates a need to repack the cylinder.
- Disassemble the down valve. Blow the plunger clean with compressed air. Reassemble and install.
- Change oil in reservoir, clean the suction screen and vent cap. Replace return line filter element.

*Notes: If holes at main pivot points are neglected and allowed to oblong, major structural problems will develop and extensive repairs will be needed.



AWKWARD PLACEMENT OF LOAD COULD CAUSE EQUIPMENT DAMAGE

Engage the hand pendant to raise or lower the lift. The hand pendant is a momentary control which allows easy operation. The unit can be started or stopped at any position throughout the unit's cycle.



WHEN LIFTING HEAVY LOADS, DO NOT JOG UNIT MORE THAN 2-3 TIMES TOO QUICKLY. WAIT APPROX. 5 SECS. BETWEEN EACH JOG. SUDDEN JOGS MAY CAUSE THE UNIT TO HAVE SURGES IN ELECTRICAL POWER. THIS COULD CAUSE THE FUSE TO TRIP EXCESSIVELY AND CAUSE

IMPROPER WEAR ON THE HYDRAULIC UNIT

To lower a product or just the unit by itself, simply depress the down button and the unit will lower. This is done without the power unit engaging.

NOTE: ANY CONTROL MODIFICATIONS OR OTHER ADJUSTMENTS MADE TO THIS EQUIPMENT WITHOUT CONTACTING SOUTHWORTH PRODUCTS WILL VOID THE WARRANTY

Lift Specifications

Construction	Fabrication from Heavy Duty T304 Stainless Steel
Capacity	Lift 2500 lbs. or 4000 lbs. (depending on model)
Platform Size	42" x 48"
Base Size	35 1/2" x 45"
Lowered Height	9 1/4"
Raised Height	36"
Elevation Time	30 seconds (approx.)
Descent Time	24 seconds (approx.)
Power Unit	Internal 110V AC, TEFC motor, 1hp
Controls	NEMA 4 footswitch
Actuation	Dual, low-pressure hydraulic cylinders, washdown, white epoxy-coated.

Troubleshooting

The chart below lists some problem/solutions that might occur due to normal wear or due to malfunction. Locate the problem situation and follow the suggested solutions.
For additional help call 800-743-1000

PROBLEM SITUATION	SUGGESTED SOLUTION
Motor to power unit does not turn on	<ul style="list-style-type: none"> *Check electrical service *Check and/or replace fuse *Contacts in switch or solenoid *Loose wires in junction box *Check and/or replace motor
Motor turns on but will not lift product	<ul style="list-style-type: none"> *Hydraulic fluid is low and needs to be filled *Pump coupling between motor and hydraulic pump has come loose or needs to be replaced *Check and/or replace hydraulic pump *Strainer has become plugged and needs to be cleaned
Motor and pump do not run smoothly	<ul style="list-style-type: none"> * Air in the hydraulic lines needs to be removed * Dirt or foreign particles in hydraulic fluid * Motor has come loose from base plate and needs tightening * Check and/or replace lovejoy coupling * Check and/or replace hydraulic pump * Check and/or replace motor
Non-level platform while raising load	<ul style="list-style-type: none"> * Air in the hydraulic cylinders needs to be removed * Flow divider is plugged
Excessive oil about base of hydraulic cylinders	<ul style="list-style-type: none"> * Hydraulic fitting to cylinder is loose and needs to be tightened * Check and/or replace hydraulic hose * O-rings in hydraulic cylinders need to be replaced

ITEM NO.	FUNCTION
2	MOTOR
3	COUPLING
4	C-FACED ADAPTER
5	END HEAD
6	O-RING
7	PUMP
8	SEAL KIT
9	SUCTION COVER
10	ELBOW
11	STRAINER
12	RESERVOIR
13	BREATHER
14	RELIEF VALVE
15	SUB PLATE
16	SOLENOID
17	COUNTERBALANCE VALVE
18	DIRECTIONAL VALVE COMLPETE
18A	DIRECTIONAL VALVE (COIL)

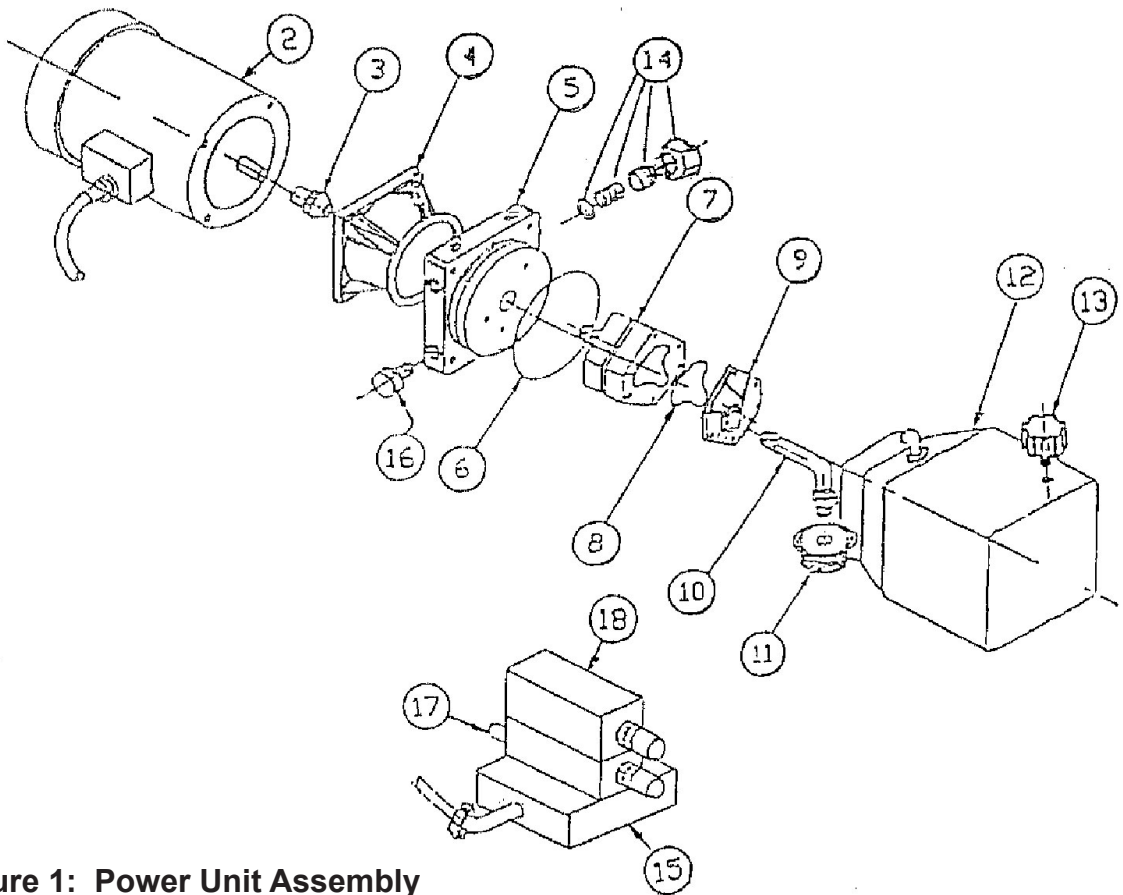

Figure 1: Power Unit Assembly

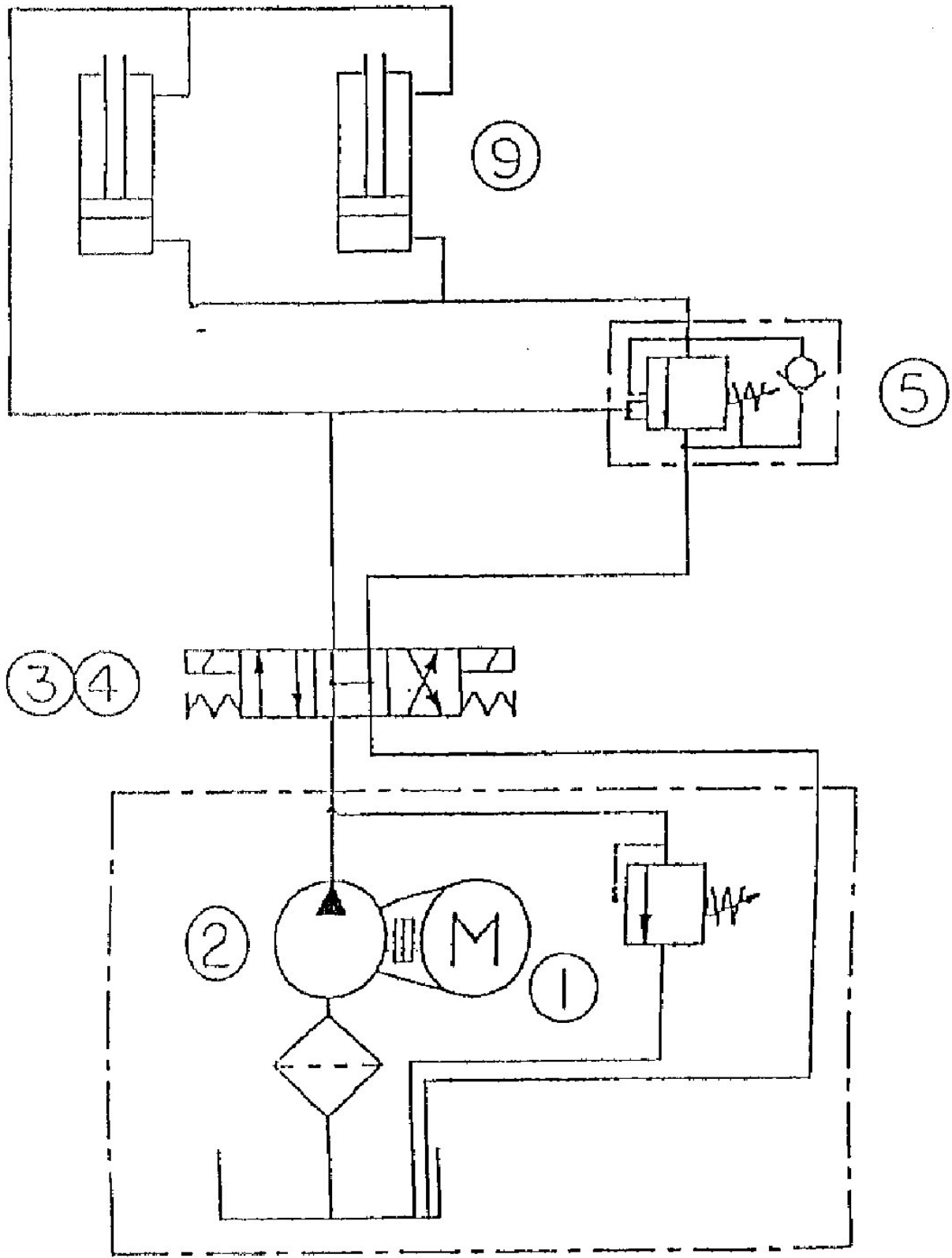

Figure 2: Hydraulic Schematic

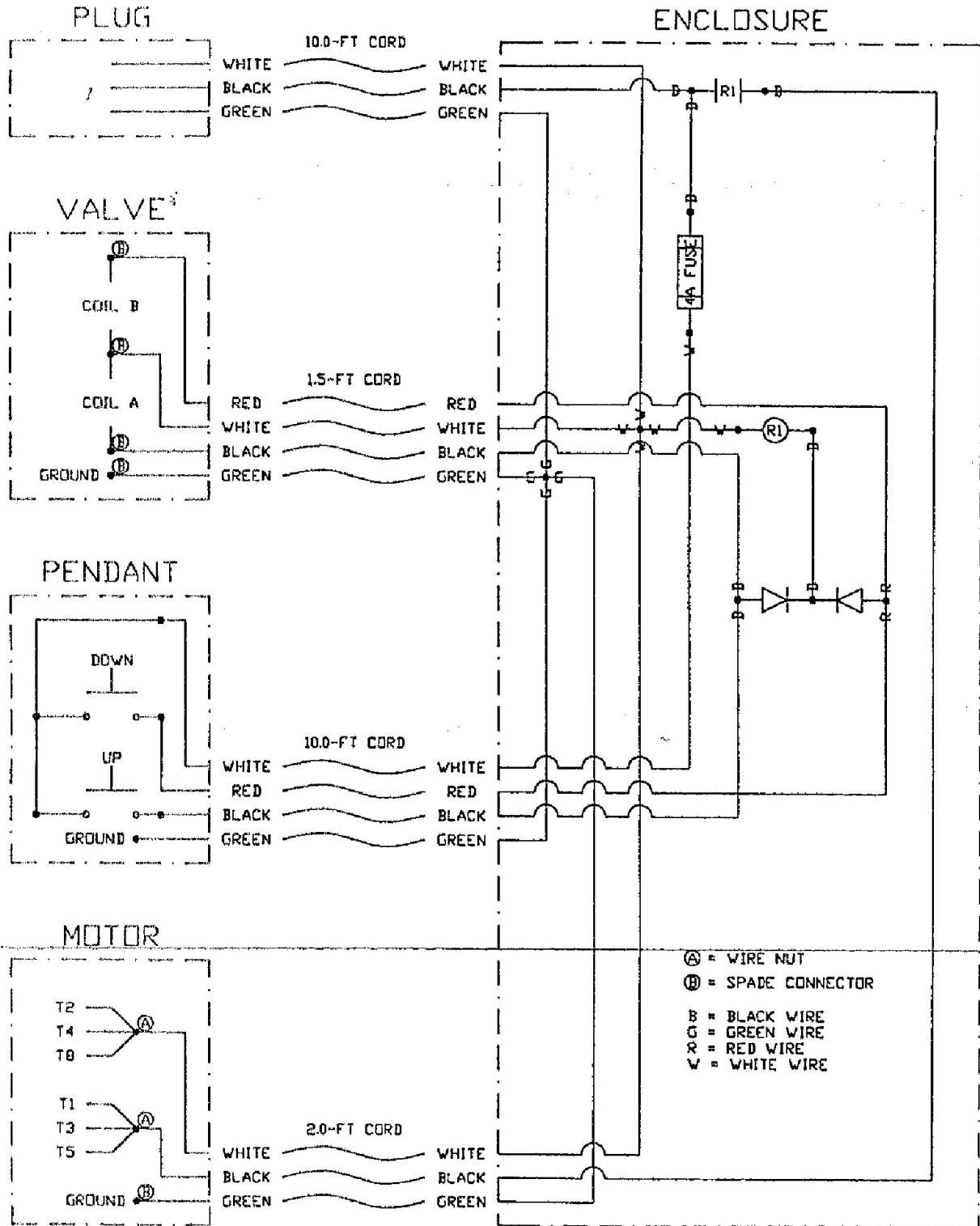

Figure 3: Electrical Schematic - Single Phase

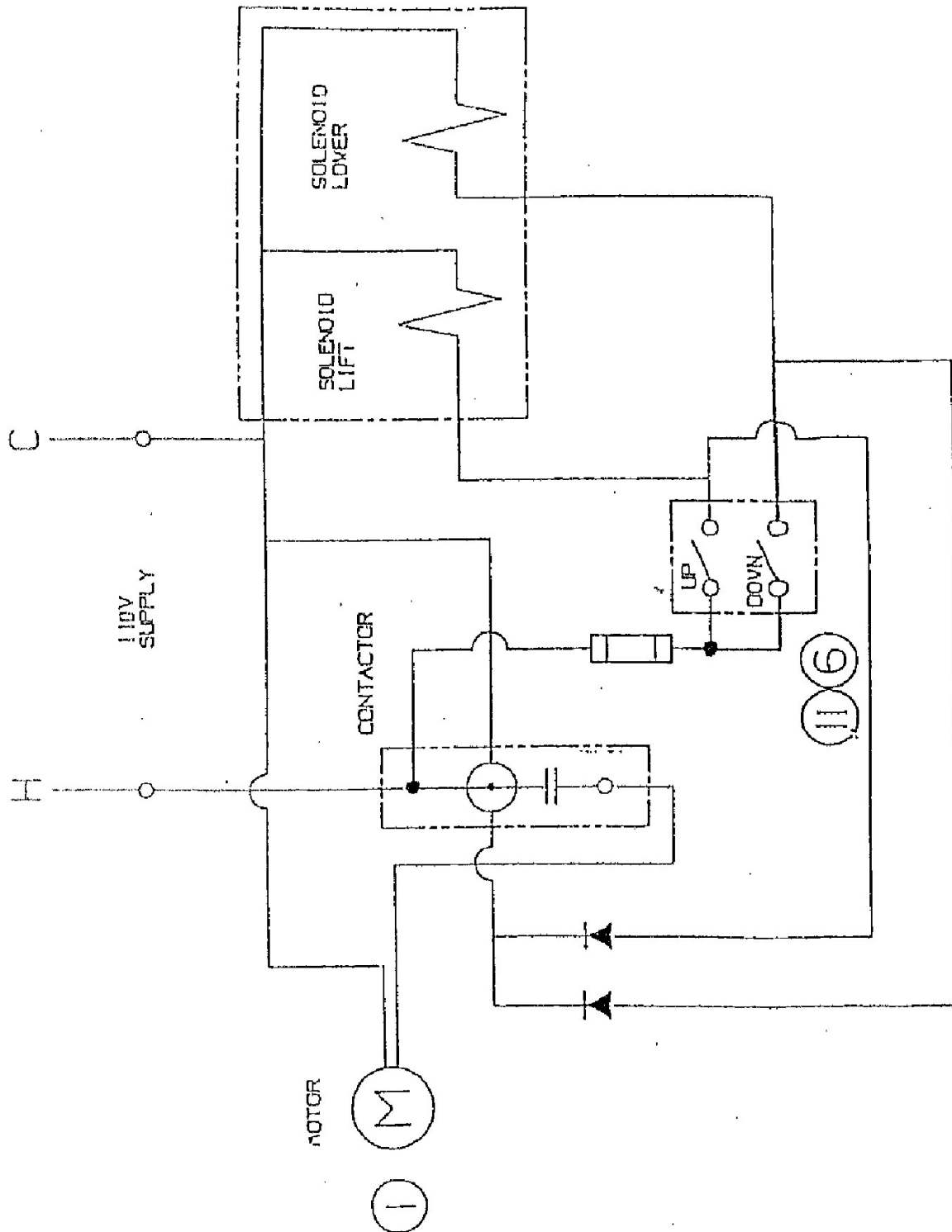

Figure 4: Electrical Schematic - Three Phase

Ordering Replacement Parts

Southworth has carefully chosen the components in your lift to be the best available for the purpose. Replacement parts should be identical to the original equipment.

Southworth will not be responsible for equipment failures resulting from the use of incorrect replacement parts or from unauthorized modifications of the machine.

Southworth will gladly supply you with replacement parts for your Southworth lift. Key parts are identified in Figures 9 and 10. With your order, please include the model number and the serial number of the lift. You can find these numbers on the name plate, which is located on the crossbar at the base of the cylinder(s). When you are ordering parts for a cylinder, also include the cylinder number. This is stamped on the base of the cylinder housing.

To order replacement parts, please call the Parts Department.

Parts are shipped subject to the following terms:

- FOB factory
- Returns only with the approval of our parts department.
- Payment net 30 days (except parts covered by warranty).
 - Freight collect (except parts covered by warranty).
- The warranty for repair parts is 30 days from date of shipment.

Parts replaced under warranty are on a “charge-credit” basis. We will invoice you when we ship the replacement part, then credit you when you return the worn or damaged part, and we verify it is covered by our warranty. Labor is not covered under warranty for Parts orders.

Parts Department

Southworth Products Corp.

Telephone 207) 878-0700 or (800) 743-1000

FAX : (207) 797-4734

repairparts@SouthworthProducts.com

www.SouthworthProducts.com

WARRANTY

Southworth Products Corp warrants this product to be free from defects in material or workmanship for a period of one (1) year from date of shipment, providing claim is made in writing within said year. This warranty shall not cover failure or defective operation caused by misuse, misapplication, negligence or accident, exceeding recommended capacities, or altering or repairing, unless alteration is authorized by Southworth Products Corp. Except as set forth herein, there are no other warranties, express or implied, including the warranties of merchantability and fitness for a particular purpose, all of which are hereby excluded.

Southworth Products Corp makes no warranty or representation with respect to the compliance of any product with state or local safety or product standard codes, and any failure to comply with such codes shall not be considered a defect of material or workmanship under this warranty. Southworth Products Corp shall not be liable for any direct or consequential damages arising out of such noncompliance.

Southworth Products Corp's obligation under this warranty is limited to the replacement or repair of defective components at its factory or another location at Southworth Products Corp's discretion. The Southworth Warranty is for product sold with in North America. For products shipped outside of North America the warranty will be for replacement of defective parts only. Labor is not included. This is buyer's sole remedy. Except as stated herein, Southworth Products Corp will not be liable for any loss, injury, or damage to persons or property, nor for direct, indirect, or consequential damage of any kind resulting from failure or defective operation of said material or equipment.

This warranty may be altered only in writing by Southworth Products Corp, Portland, Maine. Southworth Products Corp is widely acknowledged as the leading maker of hydraulic lifts and materials-handling equipment. Southworth machines are rugged and reliable, and are designed to provide years of trouble-free service. The designs are based on extensive engineering experience. These are good reasons for specifying Southworth machines in your plant.

SOUTHWORTH

SOUTHWORTH PRODUCTS CORP
P.O. Box 1380, Portland, ME 04104-1380
Telephone: (800) 743-1000 • (207) 878-0700
Fax: (207) 797-4734
www.SouthworthProducts.com

SOUTHWORTH

making work faster, safer, and easier

Southworth is the world class supplier of products designed to improve productivity and enhance safety. Our staff has over 400 years of engineering experience. If one of our standard products does not meet your needs, our engineers can custom design equipment specifically suited to your material handling application.



Spring PalletPal Load Leveler



Lift with Flush Mount Turntable



Portable Container Tilters



Dock Lifts



Roll on Level Loaders



Portable Lifts



Stack-n-Go Powered Stacker



**Floor Height Lifts
Roll-E**

**Floor to
Mezzanine Lifts**



Pallet Rotators



For more information, contact Southworth Products
Telephone (800) 743-1000 Fax (207) 797-4734
[Email: salesinfo@SouthworthProducts.com](mailto:salesinfo@SouthworthProducts.com)