

## Owner's Manual

# **SOUTHWORTH**

## **PhantomPark Lift Tables**



Model # \_\_\_\_\_

Serial # \_\_\_\_\_

Date placed in Service \_\_\_\_\_

### **SOUTHWORTH PRODUCTS CORP**

P.O. Box 1380 • Portland, ME 04104-1380

Telephone: (207) 878-0700 or (800) 743-1000

Fax: (207) 797-4734

[www.SouthworthProducts.com](http://www.SouthworthProducts.com)

Email: [service@SouthworthProducts.com](mailto:service@SouthworthProducts.com)

Revised July 2015

Please note: This manual was current at the time of printing.  
To obtain the latest, most updated version, please contact Southworth's  
Customer Service Department or go to our website: [www.SouthworthProducts.com](http://www.SouthworthProducts.com),  
under Parts & Service/Online Manuals.  
You will find a complete list of current  
owner's manuals to print.

# Contents

INTRODUCTION .....	4
RESPONSIBILITY OF OWNERS AND USERS .....	5
SAFETY ALERT SYMBOLS AND SIGNAL WORDS.....	6
SAFE SERVICING OF THE LIFT .....	7
SAFETY.....	8
INSTALLATION INSTRUCTIONS .....	9
Preparation .....	9
Positioning the Lift .....	10
Hydraulic Connections .....	4
Electrical Connections .....	5
Testing .....	5
Completing Installation.....	5
OPERATING INSTRUCTIONS.....	6
Operating Procedure .....	6
MAINTENANCE .....	7
Hazards .....	7
Routine Periodic Maintenance .....	7
TROUBLESHOOTING .....	9
Troubleshooting Check List.....	9
Repacking Cylinders .....	11
Replacing Leg Rollers.....	12
Ordering Replacement Parts .....	13
WARRANTY .....	Back Cover

## List of Figures

Fig. 1 .....Safe Servicing of Lift .....	7
Fig. 2 .....Mount the Lift Securely .....	8
Fig. 3 .....Pinch Points .....	19
Fig. 4 .....Labels and Precautionary Markings .....	21
Fig. 5 .....J-Style Cylinder .....	25
Fig. 6 .....Parts Identification .....	26
Fig. 7 .....Standard 3.2 HP Power Unit .....	27
Fig. 8 .....Hydraulic Pump and Down Valve .....	27
Fig. 9.....Hydraulic Schematics.....	28
Fig. 10.....Wiring Diagram.....	29
Fig. 11.....Electrical Arrangement .....	30
Fig. 12 .....Hydraulic Connections .....	31
Fig. 13 .....Hydraulic Diagram .....	32
Table 1 ....Hydraulic Oil Specifications .....	32

### INTRODUCTION

This manual contains information to acquaint you with the safe and proper installation, use, and upkeep of a PhantomPark series lift. You should ensure that this manual is available to personnel working with and on the lift and require its use by these personnel.

The PhantomPark Lift is designed for lifting vehicles from one floor to another in a safe efficient manner. The instructions set forth in this manual are not necessarily all-inclusive, as Southworth cannot anticipate all conceivable or unique situations.

**In the interest of safety, please read all of this manual carefully, and be familiar with its contents before you install, use, or service the PhantomPark Lift. If you have any questions about any of the instructions in this manual, please contact your dealer or Southworth Products Corp.**

Southworth's product warranty is shown on the back cover of this manual.

**This instruction manual is not intended to be or to create any other warranty, express or implied, including any implied warranty of merchantability or fitness for a particular purpose, all of which are hereby expressly excluded.**

As set forth more specifically in the product warranty, Southworth's obligation under that warranty is limited to the repair or replacement of defective components, which shall be the buyer's sole remedy, and Southworth shall not be liable for any loss, injury, or damage to persons or property, nor for any direct, indirect, or consequential damage of any kind resulting from the PhantomPark lift.

## **Responsibility of Owners and Users**

### **Inspection and Maintenance**

The device shall be inspected and maintained in proper working order in accordance with Southworth's owner's manual.

### **Removal from Service**

Any device not in safe operating condition such as, but not limited to, excessive leakage, missing rollers, pins, or fasteners, any bent or cracked structural members, cut or frayed electric, hydraulic, or pneumatic lines, damaged or malfunctioning controls or safety devices, etc. shall be removed from service until it is repaired to the original manufacturer's standards.

### **Deflection**

It is the responsibility of the user/purchaser to advise the manufacturer where deflection may be critical to the application.

### **Repairs**

All repairs shall be made by qualified personnel in conformance with Southworth's instructions.

### **Operators**

Only trained personnel and authorized personnel shall be permitted to operate the lift.

### **Before Operation**

Before using the device, the operator shall have:

- Read and/or had explained, and understood, the manufacturer's operating instructions and safety rules.
- Inspected the device for proper operation and condition. Any suspect item shall be carefully examined and a determination made by a qualified person as to whether it constitutes a hazard. All items not in conformance with Southworth's specification shall be corrected before further use of the equipment.

### **During Operation**

The device shall only be used in accordance with this owner's manual.

- Do not overload.
- Ensure that all safety devices are operational and in place.

### **Modifications or Alterations**

Modifications or alterations to any Southworth industrial positioning equipment shall be made only with written permission from Southworth.

## SAFETY ALERT SYMBOLS AND SIGNAL WORDS

The safety of all persons operating, maintaining, repairing, or in the vicinity of this equipment is of paramount concern. This is a powerful machine with moving parts, and is capable of causing personal injury if proper precautions are not taken. Therefore, throughout this manual, certain hazards have been identified which may occur in the use of the machine, and there are appropriate instructions or precautions which should be taken to avoid these hazards. In some cases, there are consequences which may occur if instructions or precautions are not followed. Below are the symbols and signal words along with their definitions referenced from ANSI Z535.4 - Product Safety Signs and Labels.

### Safety Alert Symbols

These are the safety alert symbols.. They are used to alert you to potential physical injury hazards. Obey all safety messages that follow this symbol to avoid possible injury or death.



For use with **DANGER** signal word  
(Red Background)



For use with **WARNING** signal word  
(Orange Background)



For use with **CAUTION** signal word  
(Yellow Background)

### Signal Words

The meaning of different signal words as defined by ANSI Standard Z535.4 indicates the relative seriousness of the hazardous situation.



(Red Background)

DANGER indicates a hazardous situation which, if not avoided, will result in death or serious injury.



(Orange Background)

WARNING indicates a hazardous situation which, if not avoided, could result in death or serious injury.



(Yellow Background)

CAUTION, used with the safety alert symbol, indicates a hazardous situation which, if not avoided, could result in minor or moderate injury.



(Blue Background)

NOTICE is used to address practices not related to personal injury.



(Green Background)

SAFETY INSTRUCTIONS (or equivalent) signs indicate safety-related instructions or procedures.

## Safe Servicing of the Lift

### **⚠ WARNING**

Only authorized personnel should perform inspection or maintenance and service procedures. Unauthorized personnel attempting these procedures do so at the risk of severe injury or death.

### **⚠ DANGER**

Failure to properly adhere to lift blocking procedures is to risk the sudden and uncontrolled descent of the lift during maintenance or inspection. A falling lift can cause severe injury or death.

This procedure describes the only factory-approved method of working under a lift. Follow these instructions **EVERY** time you plan to reach or crawl beneath the lift to perform service or maintenance – no matter how momentary that might be.

If the factory-provided maintenance device is damaged or missing, stop immediately and consult the factory for assistance. The manufacturer is not liable for your failure to use the approved maintenance device(s) and procedures that have been provided.

1. Any load must be removed from the lift prior to engaging the maintenance device(s). These devices are designed to support an unloaded lift only. Failure to remove the load from the lift prior to blocking could cause the failure of the maintenance device(s) and allow the lift to fall unexpectedly. This can result in personal injury or death, or permanent damage to the maintenance device(s) and/or the lift.
2. Raise the lift to its fully raised position. If you do not, the maintenance device(s) may not be able to be placed properly in its/their designed blocking position.
3. Remove the maintenance device(s) from its/their storage location and place it/them into the engaged position as shown in Figure 1. (Note: further information may be useful here to provide additional instructions as to the location and method of storage and engaged positions).
4. Lower the lift until it makes complete contact with the maintenance device(s). Re-check to ensure that all provided devices are fully and securely engaged. If the device(s) is/are not fully engaged the lift could fall unexpectedly, resulting in permanent damage to the device(s) or the lift.

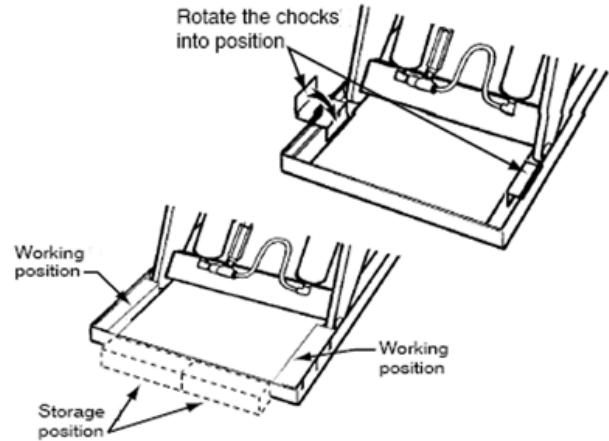

Figure 1 – Safe Servicing of Lift

### **⚠ DANGER**

If for any reason you are unable to lower the lift completely onto the maintenance device(s), stop immediately and consult the factory. Failure to properly use the factory approved maintenance device(s) could result in severe injury or death.

5. Once the maintenance device(s) is/are properly and securely engaged, continue to press the down button, valve or switch for an additional 5-10 seconds to relieve all pressure in the operating system.

### **⚠ WARNING**

Failure to relieve operating system pressure could result in the sudden and unexpected release of high pressure fluids (or air) during maintenance and/or repair of the lift and result in severe injury or death.

6. Follow OSHA electrical lock-out/tag-out procedures. Disconnect and tag all electrical and/or other power sources to prevent an unplanned or unexpected actuation of the lift.
7. Once inspection or work is complete, reverse the performance of the steps above to raise the lift off the maintenance device(s) and place the device(s) back into its/their designated storage position(s).

### **⚠ DANGER**

**HIGH VOLTAGE ! – Disconnect and/or lock out the electrical supply to the power unit prior to any installation or maintenance being performed.**

## SAFETY

The safety of all persons operating, maintaining, repairing, or in the vicinity of the PhantomPark lift is of paramount concern to Southworth. The lift is a powerful machine with moving parts, and is **capable of causing personal injury if proper precautions are not taken.**

Therefore, throughout this manual, Southworth has identified certain hazards which may occur in the use of the lift, and provided appropriate **instructions** or **precautions** which should be taken to avoid these hazards.

In some cases, Southworth has also pointed out the **consequences** which may occur if Southworth's instructions or precautions are not followed. Southworth uses the following system of identifying the severity of the hazards associated with its products:

**⚠ DANGER** - Immediate hazard which will result in severe personal injury or death.

**⚠ WARNING** - Hazard or unsafe practice which could result in severe personal injury or death.

**⚠ CAUTION** - Hazard or unsafe practice which could result in minor personal injury or property damage.

**Please read and follow this instruction manual, including all safety instructions and precautions, carefully and completely.**

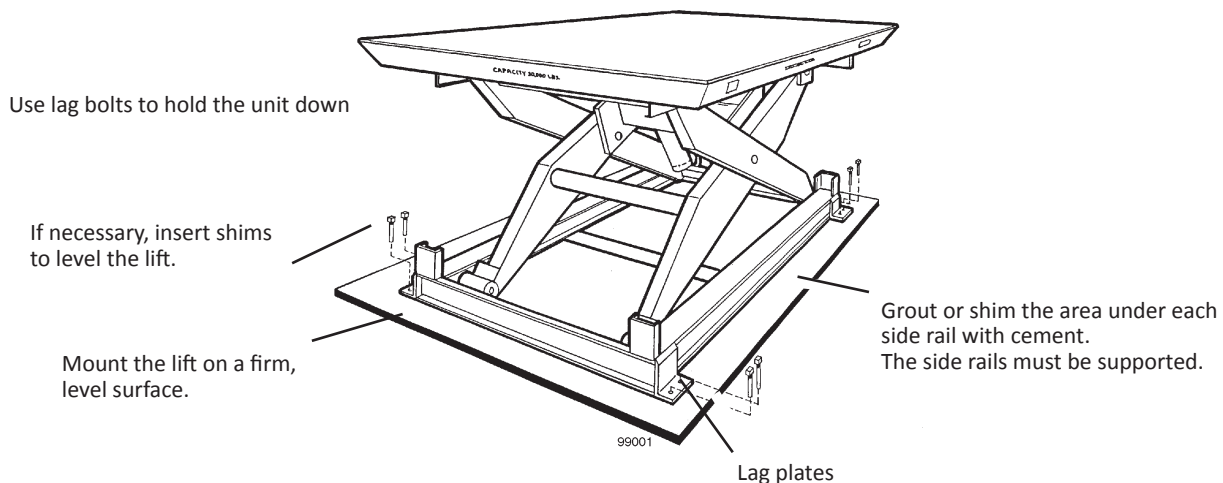

**Fig. 2 – Mount the Lift Securely**



# INSTALLATION INSTRUCTIONS

## Preparation

Before you start to install the lift, check for local codes and ordinances which may apply. It is your responsibility to obtain any necessary permits.

**Read all of these installation instructions carefully. Be sure to read and understand all of the warnings!**

If your unit is designed to be installed in a pit, check the pit before you start to install the lift. Measure the length and width of the lift, then measure the pit, and be sure the pit allows adequate clearance. Does the pit have 90° angles at each corner? To check, measure across the opposite corners of the pit. The measurement on each diagonal should be the same, within 1/2 inch. The walls of the pit should be vertical. Check with a carpenter's square. The pit should be 1 1/2 times larger than the platform.

If the power unit will be mounted away from the lift ("external power unit"), check the mounting arrangement for the power unit. The power unit should be sheltered from the weather. It should be mounted within 30 feet of the lift to minimize the pressure drop in the hydraulic system. Be sure the hydraulic lines have been installed properly.

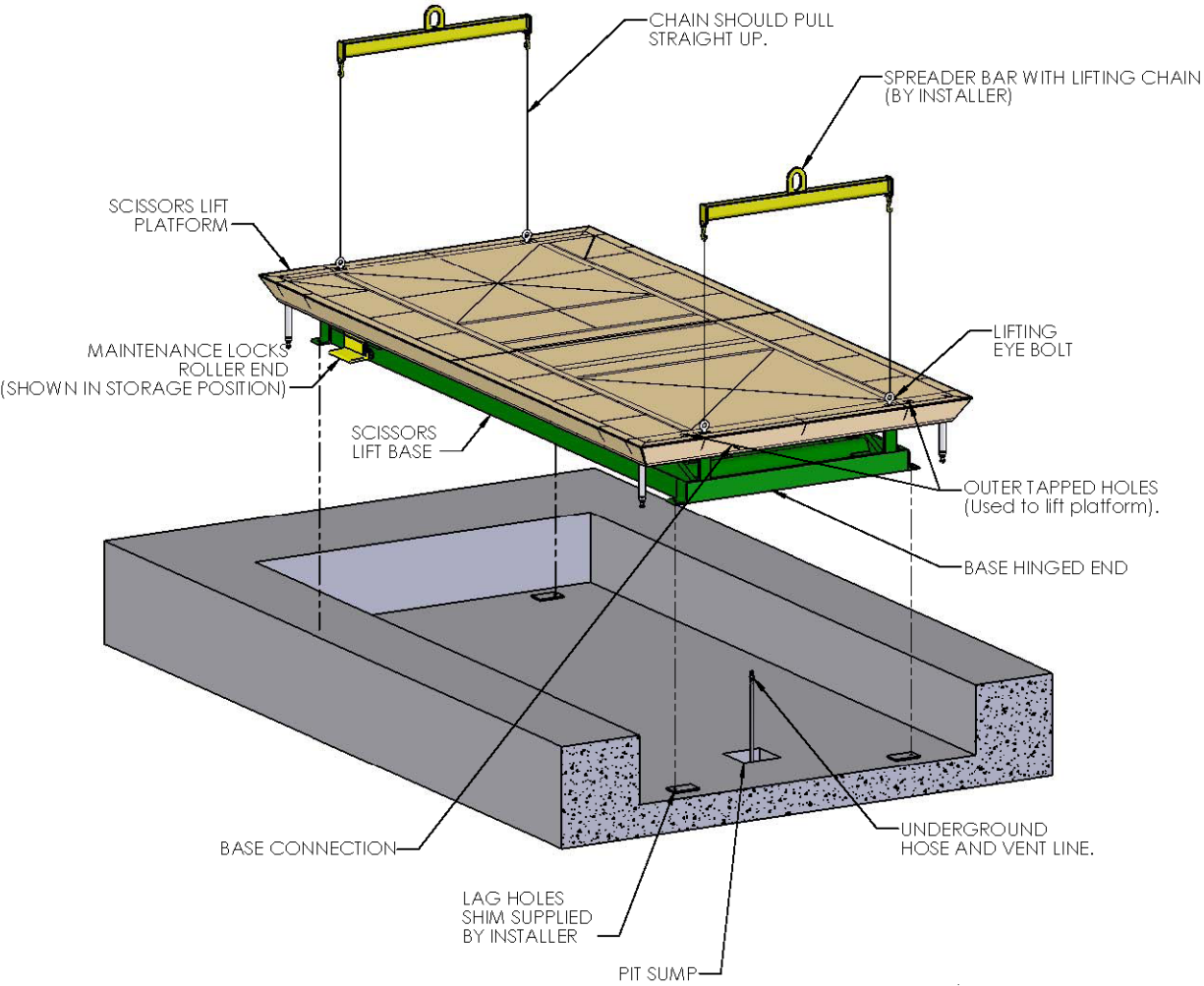

Step by Step Installation Procedures on page 10.

## Phantom Park Lift

### **⚠️WARNING**

Protect the power unit from rain or moisture. If the electrical parts in the power unit get wet, workers may be hurt by electrical shock. The electrical parts may fail if they are wet.

### **⚠️WARNING**

The electric motor in the lift can create sparks. Don't install the power unit in an area where flammable gases may be present.

If the power unit will be mounted away from the lift ("external power unit"), you will also need:

- A compressed air source for clearing the hydraulic lines.
- Extra hydraulic oil for flushing the underground lines and refilling the tank. See Table 2 for the oil specifications.

## INSTALLATION PROCEDURE: (External Power Unit Model)

**CAUTION:** Do not allow personnel under platform without support

### - READ ENTIRE INSTRUCTIONS FIRST -

1. Install power unit inside building at location designated, should be within 30 ft. of lift unit.
2. Install wiring to power unit inside building. See electrical schematic.
3. Arrange chain sling as shown in figure 1.
4. Remove lag bolts from base to skid.
5. Raise lift and place in pit.
6. Loosen eye bolts until disengaged from base. Screw two (2) eye bolts into the two outer tapped holes in order to lift platform. See figure 2.
7. Rehook sling arrangement through eye bolts and raise platform to full height, lifting from one end only.
8. Swing two maintenance locks into maintenance position. See figure 3.
9. Lower platform until lower leg rollers rest on the locks. See figure 3.
10. Blow out underground hoses with air, connect to power unit.
11. Take hydraulic hose and vent hose from pit and place near fittings in base.
12. Run limit switch wires through conduit and connect to control panel.
13. Jog hydraulic power unit until underground hose is full of oil.
14. Connect the hoses to the appropriate fittings in base.
15. Run motor to just raise lift off maintenance locks.
16. Maintenance locks must be put back into storage position.
17. Remove sling from lifting eyebolts.
18. Lower lift with down button and align lift in pit.
19. Raise lift to check alignment.
20. Swing maintenance locks into maintenance position and lower lift until rollers rest on locks.
21. Mark location of lag bolts through hole in lag angles in lift base.
22. Drill for lag studs and install shims (shims supplied by installer) to level base and align lift to pit at lower level and rectangular hole in floor at the upper level.
23. Install lag studs.
24. **Important!** Grout or shim with steel flat bar under base in areas where rollers travel and base hinged end. See figure 4.
25. Adjust limit switch to desired stopping position.
26. Run lift up and down several times to remove any air in hydraulic system. Add oil as necessary to tank. Tank to be full within 1/2" from top.
27. Clean up any spilled oil for safety. Spilled oil may be misinterpreted as a leak.

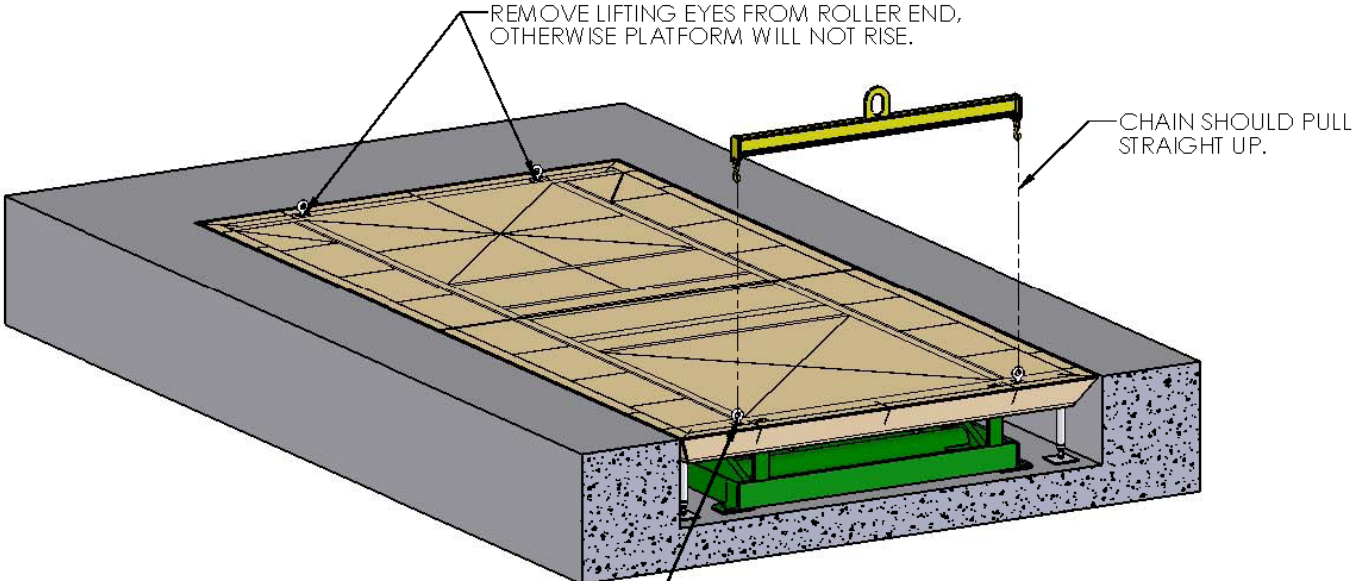

LIFTING EYES MOVED TO THE TWO OUTER TAPPED HOLES IN ORDER TO LIFT JUST THE PLATFORM.

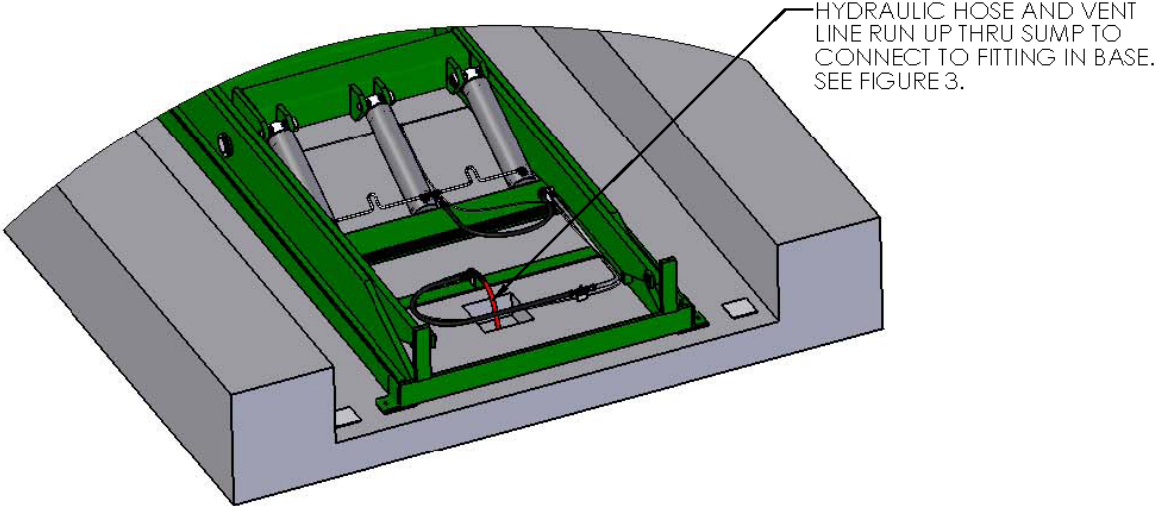

## Phantom Park Lift

REFER TO NOTES TO  
RAISE THE PLATFORM.

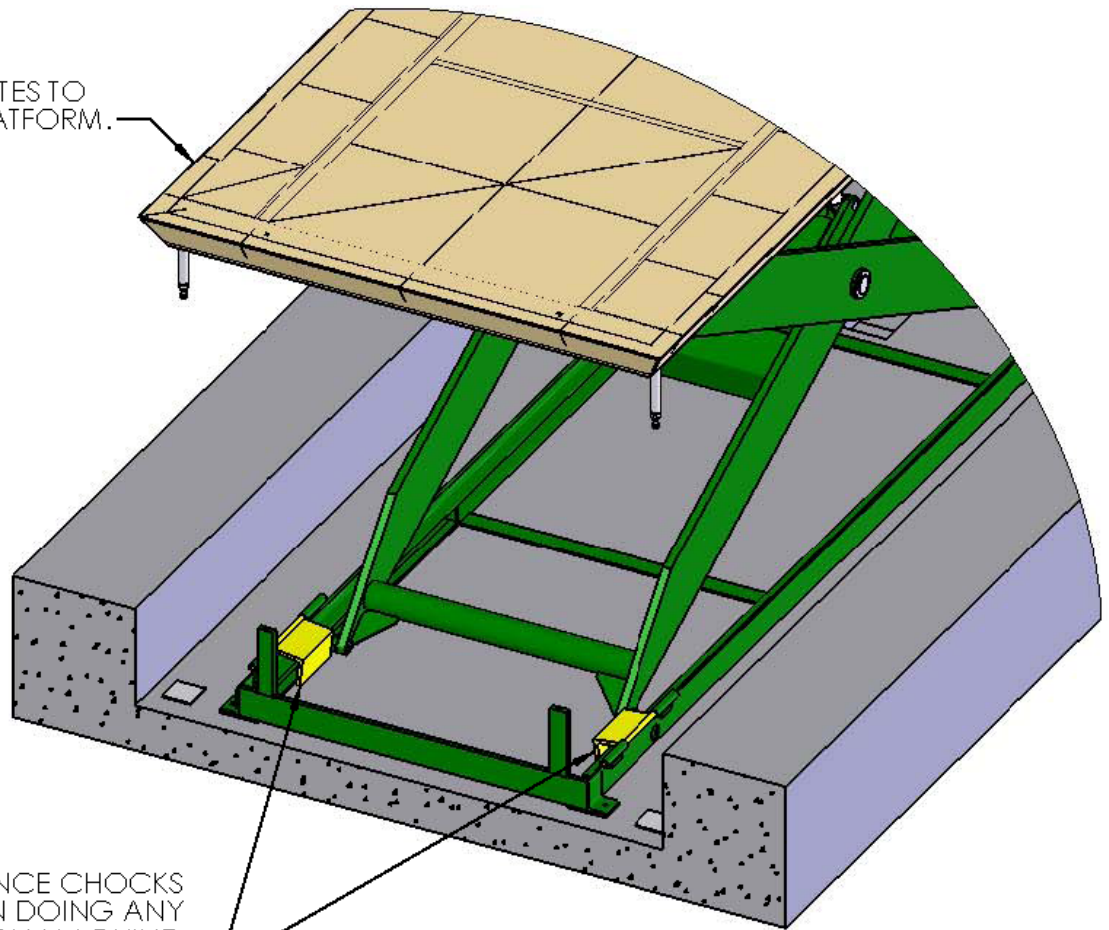

MAINTENANCE CHOCKS  
FLIPPED IN WHEN DOING ANY  
MAINTENANCE ON MACHINE.  
REFER TO NOTES ON SHEET 1.

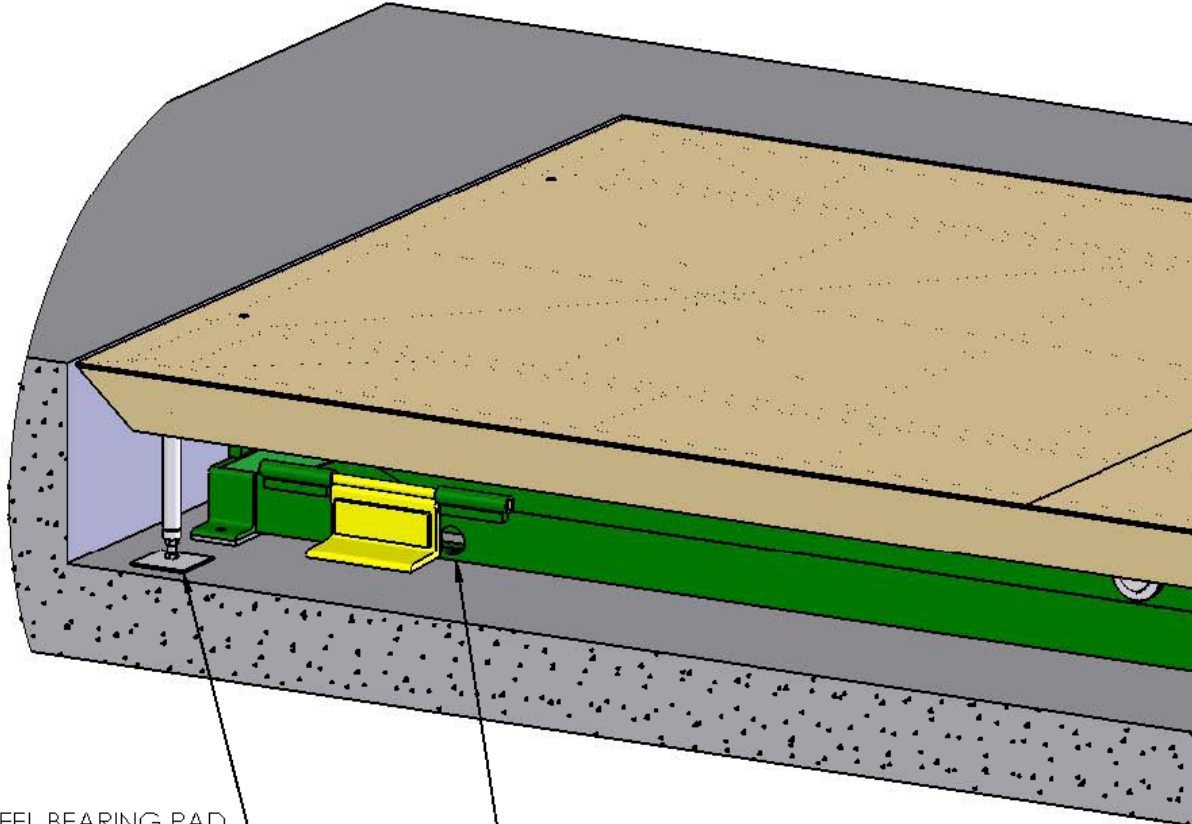

STEEL BEARING PAD  
BY INSTALLER. TYP.  
4 PLACES.

**VERY IMPORTANT!**  
GROUT OR SHIM UNDER AREAS  
WHERE THE ROLLERS TRAVEL.

**THE SCISSORS LIFT MUST BE INSTALLED LEVEL SO  
THAT WHEN IT IS RAISED IT WILL BE CENTERED TO  
THE RECTANGULAR HOLE IN THE FLOOR ABOVE.**

## Phantom Park Lift

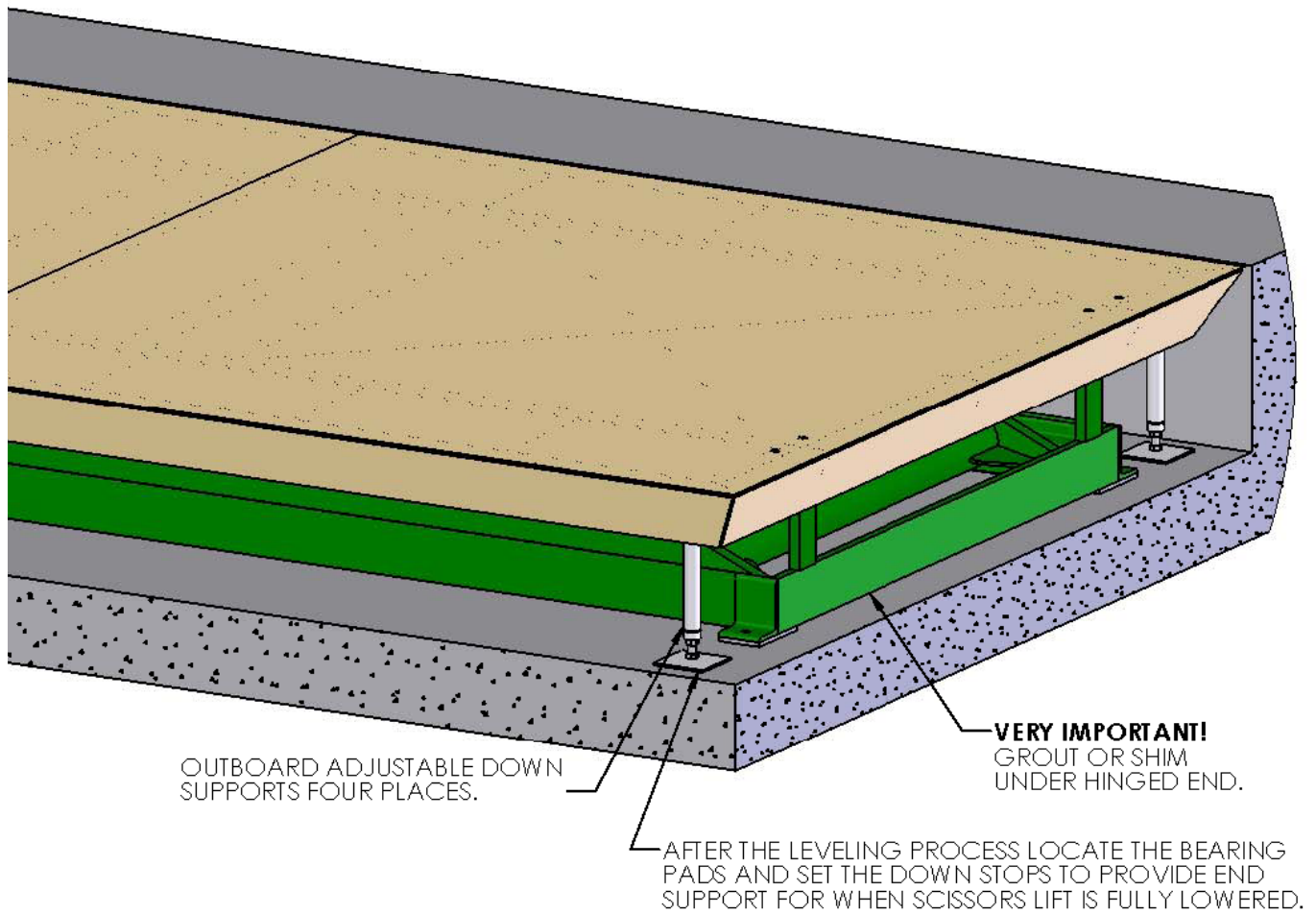

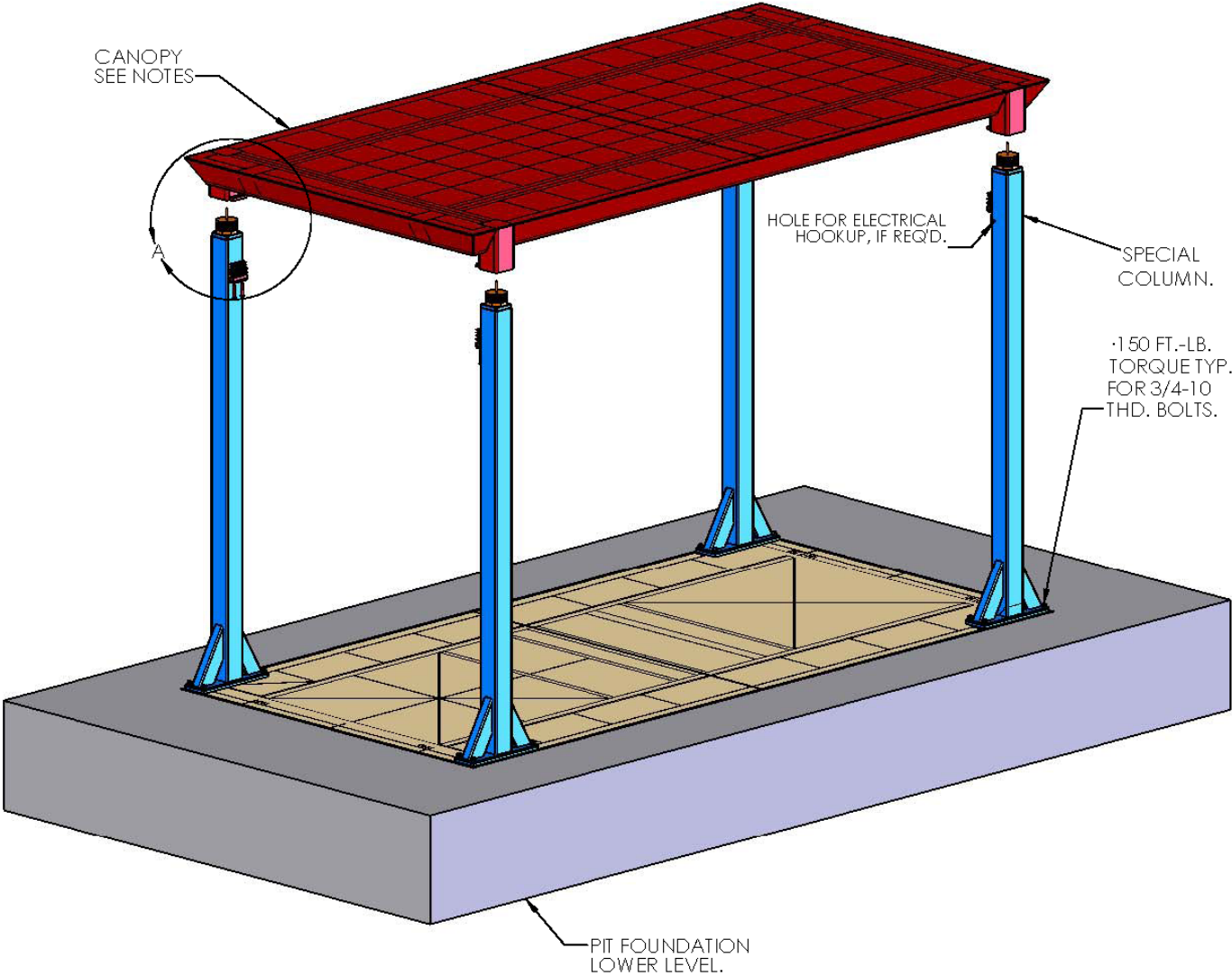

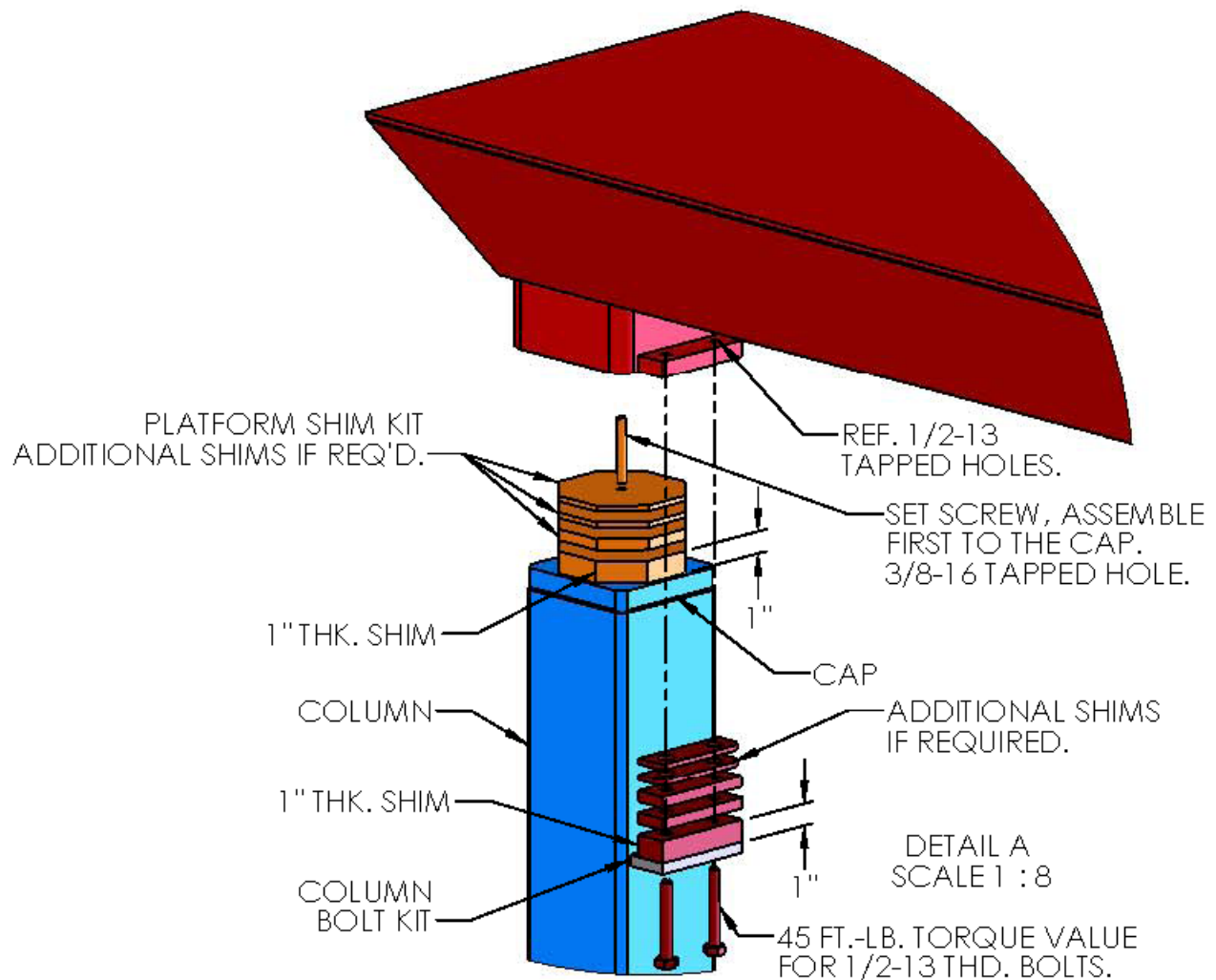

NOTES:

1. BY INSTALLING A 1" THICK SHIM, THE DIMENSION FROM THE SURFACE OF THE CANOPY TO THE SURFACE OF THE SCISSORS LIFT PLATFORM SHOULD MATCH THE DIMENSIONS SHOWN ON THE TOP ASSEMBLY DRAWING 443XXXX.
2. IF IN THE FIELD, THE TWO FLOORS ARE DIFFERENT THEN REPORTED, THE SHIM KIT WILL ACCOMODATE A +/- 1" VARIANCE.
3. THE SET SCREW IS USED TO KEEP THE SHIMS FROM FALLING OFF DURING THE CANOPY ASSEMBLY. THE CAP ON THE COLUMN HAS A 3/8-16 THREADED HOLE FOR THE SET SCREW.
4. WHEN THE CANOPY HEIGHT HAS BEEN DETERMINED, ADVANCE THE SET SCREW 1/16" LOWER THAN THE TOP SHIM, TYPICAL.



## Hydraulic Connections

Install the power unit. Install the hydraulic line between the power unit and the lift as shown on the pit plan.

Blow out the hydraulic line with compressed air before connecting it to the lift. Replace the solid plug on the hydraulic fluid tank with the vented plug supplied, then attach the vent line to the vented plug.

### **⚠ WARNING**

Be sure that the hydraulic line will not be pinched by the lift as it raises or lowers. If you allow the line to be pinched, the lift may not work properly. A hose may break, the lift may drop suddenly, and someone may be hurt.

### **⚠ CAUTION**

It is very important to keep the hydraulic oil free of dirt, dust, metal chips, water, and other contamination. Most of the problems with hydraulic systems are caused by contamination in the oil. Be sure to flush all hydraulic lines before connecting remote power units.

### **⚠ CAUTION**

If you do not install the vented plug in the tank, the pump may be damaged.

## Electrical Connections

### **⚠ DANGER**

The lift may use a power supply of up to 575 Volts AC. This voltage can kill you. Do not work with the electrical parts unless you are a qualified electrician.

Make temporary electrical connections to the lift. This temporary set-up will allow you to raise the lift and make final wiring connections.

### **⚠ WARNING**

The fusing requirements are shown in Table 1. To avoid fire danger, follow these requirements.

On a lift designed for three-phase AC, you must be sure the pump motor is turning in the right direction. The lift should start to move quickly when you press the “up” or “down” button. If the lift does not move in 2 or 3 seconds, do not try to operate the lift! Exchange any two of the three-phase leads. If this does not correct the problem, see the troubleshooting instructions at the end of this manual.

### Raise and chock the lift.

Make the permanent electrical connections as required.

Check the level of the hydraulic fluid. On most models, when the lift is fully elevated, the oil should be about 3/4 inch above the bottom of the tank. Use a dipstick to check the oil level, and add oil as necessary.

## Testing

Clear the area around the lift. Remove any loose wires, lumber, or other materials which might get in the way of the lift as it raises or lowers.

Remove the maintenance chocks and warn others to stay away from the lift. Operate the lift through its full range of travel. The lift should rise smoothly with a quiet humming sound, and lower smoothly and quietly. Raise and lower the lift a few times to check the clearances around the lift.

### **⚠ WARNING**

As the lift moves up and down, “pinch points” are created at the places shown in Figure 4. If you are standing too close to the lift when it is moving, your arm or leg may be caught in the moving parts, and you may be hurt. Stay away from the pinch points when the lift is moving.

## Completing Installation

If your lift is mounted in a pit, align the unit with the sides of the pit. Once you are sure the lift is positioned correctly, mark the locations of the lag holes in the base frame, and drill the holes. If necessary, insert metal shims to level the base of the lift. Insert and tighten the lag bolts to secure the lift. Grout under the base rails to prevent vibration and distortion of the base frame, as shown in Figure 2.

If the lift is lowering too quickly or too slowly, you can change the “down speed” by adjusting the flow control. The flow control may be mounted either internally, at the base of the cylinders, or on the external power unit.

### **⚠ WARNING**

When adjusting the flow control, always raise the lift and insert the maintenance chocks, as shown in Figure 1. Do not try to adjust the flow control while pressing the “down” button. If you try this, the lift may drop suddenly, and you may be hurt.

## Phantom Park Lift

It is important that you follow these steps when adjusting the flow control:

- **Raise the lift and insert the maintenance chocks**, as shown in Figure 1.
- If you want the lift to lower more slowly, turn the control clockwise up to 1/4 turn at a time. If you want the lift to lower more quickly, turn the control counterclockwise up to 1/4 turn. Don't move the control more than 1/4 turn at a time.
- Remove the maintenance chocks, and check the descent speed.
- Every time you want to change the adjustment again, raise the table again and insert the maintenance chocks as shown in Figure 1.

Test the lift with the rated load. If the lift does not rise, and you hear a loud squealing noise, the pressure relief valve is operating. Contact Southworth for instructions.

### **⚠️ WARNING**

**Don't continue to use the lift if this happens. The pump will overheat very quickly, and may be permanently damaged. Do not try to adjust the relief valve. If you change the setting on the relief valve, you may overwork the lift. This can cause the lift to fail suddenly, and you may be hurt.**

As a final step, clean up all spilled hydraulic fluid. Spilled hydraulic oil is slippery, and may present a fire hazard.

## OPERATING INSTRUCTIONS

### Operating Procedure

Before operating the lift, read and understand this entire section.

Load the lift correctly.

- Be sure that the vehicle weighs no more than the maximum rated for the lift. The maximum rated load is shown on the platform skirt.

### **⚠️ WARNING**

**Do not try to lift a load that exceeds the maximum rating. If you try this, the lift may fail suddenly. Someone may be hurt, and the lift and load may be damaged.**

- Do not try to load the lift while the lift is moving.

Be sure all people in the area are clear of the lift. Remove any lumber or other material which may fall onto the lift.

### **⚠️ WARNING**

**As the lift moves up and down, "pinch points" are created as shown in Figure 4. Stay away from these pinch points! Part of your body or clothing may become caught, and you may be hurt.**

Operate the lift. Press and hold the "up" button to raise the lift, and "down" to lower it. Release the button when the lift reaches the limit of travel. If the lift does not operate within 2 or 3 seconds, turn off the lift and call a qualified maintenance worker.

### **⚠️ WARNING**

**If you hear a squealing noise from the pump, the pressure relief valve is operating. Do not continue to use the lift! The pump will overheat very quickly, and may be permanently damaged. The relief valve is included to protect the machine operators – don't change the relief pressure setting.**

Wait until the lift has stopped. Unload the lift.

### **⚠️ WARNING**

**The warning labels on the lift are there for your safety. If you find that the labels are worn or missing, or have been painted over, ask Maintenance to replace the labels before you use the lift. The labels are shown in Figure 5.**

## MAINTENANCE

All servicing should be done by qualified personnel. Qualified personnel should be able to read and understand wiring and hydraulic diagrams. They should be able to troubleshoot live electrical circuits safely and in accordance with accepted practice. **For safety's sake**, if in doubt, please contact your dealer or Southworth Products Corp Service Department at (207) 878-0700 or (800) 743-1000.

Before servicing the lift, read and understand this entire section and the section entitled "Operating Instructions."

## Hazards

There are several hazards you should be aware of as you service the lift:

### DANGER!

The lift may use a power supply of up to 575 Volts AC. This voltage can kill. Do not work with the electrical parts unless you are a qualified electrician!

### WARNING

- As the lift moves up and down, "pinch points" are formed as shown in Figure 4. Keep hands, feet, and loose clothing away from these pinch points. If your hand or arm or a part of your clothing is caught, you may be hurt.
- A falling lift can cause severe personal injury.

Before working under the lift, raise the lift and insert the maintenance chocks, as shown in Figure 1. Do this every time you work under the lift!

- Do not change the setting on the relief valve. If you do change the setting, this may cause a hydraulic part to fail. The hydraulic components in the lift are designed to handle a certain amount of pressure. If the relief valve does not open, this pressure may be exceeded. The lift may drop suddenly. Someone may be hurt, and the lift and load may be damaged.
- Release of fluids under high pressure can cause personal injury. Before you open any part of the hydraulic system, be sure to release the hydraulic pressure.
- The warning labels on the lift are there for the safety of the operators. See Figure 5.
- If the labels are worn or missing, or have been painted over, replace them before releasing the lift for operation.

## Routine Periodic Maintenance

Every three months:

Visually inspect the leg rollers, center pivot bushings and pins, cylinder clevis pins and bushings, and the leg hinge pins and bushings for signs of wear. Contact Southworth for instructions for repair of the center pivot pins and bushings.

Apply light oil or WD-40 to the parts listed in the

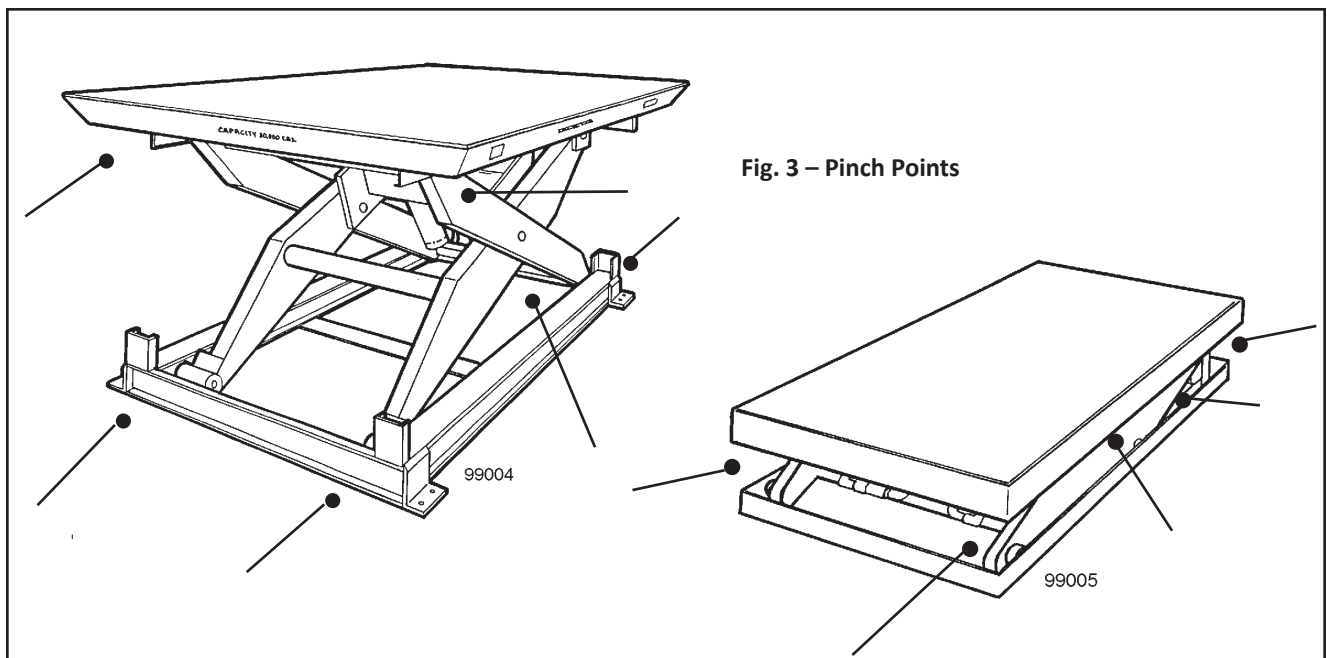

## Phantom Park Lift

last step.

NOTE: Although the bearings are “lifetime lubricated” their performance may be extended by additional periodic lubrication.

Check the level and appearance of the hydraulic fluid. First, **raise the lift and insert the maintenance chocks, as shown in Figure 1.** On most models, when the lift is fully elevated, the oil should be about 3/4 inch above the bottom of the tank. Use a dipstick to check the oil level, and add oil as necessary. Change the oil if it has darkened, or feels gritty or sticky.

### CAUTION

It is important to use hydraulic fluid with the correct grade and properties. See the hydraulic oil specification in this manual, Table 2.

Every six months or 500 hours of operation, whichever comes first:

**Raise the lift and insert the maintenance chocks, as shown in Figure 1.**

Check all of the hydraulic fittings and hoses, and repair the connections as necessary. Occasionally the fittings can be worked loose by the vibrations from the power unit.

### WARNING

If a hydraulic fitting becomes loose, or if a hydraulic hose breaks, the hydraulic fluid may escape from the system under pressure. If the lift is raised when this happens, it can drop quickly. Someone may be hurt, or the lift or load may be damaged.

The clear plastic vent line and the cylinder rod(s) should be free of hydraulic fluid. If you find much fluid in either place, the cylinder seals may be leaking. (It is also possible the tank may be overfilled.) See the section on “Repacking Southworth Cylinders.”

Disassemble the down valve as shown in Figure 9. Blow the valve plunger clean with compressed air. Reassemble and reinstall.

Drain and discard the hydraulic fluid. The suction filter is in the tank, at the point where the suction line runs out to the pump. Unscrew the hydraulic filter. Blow the filter clean. Reinstall the filter in the tank and reassemble the hydraulic line.

Refill the tank with new hydraulic fluid.

### CAUTION

If you continue to use fluid after it has “worn out,” the moving parts in the system will wear more quickly.

Be sure all of the warning labels are in position and legible. The labels are shown in Figure 5. **The warning labels are intended to protect your workers.** If the labels are missing, or if they have been painted over, replace them.

## TROUBLESHOOTING

### Troubleshooting Check List

All servicing should be done by qualified personnel. Qualified personnel should be able to read and understand wiring and hydraulic diagrams. They should be able to troubleshoot live electrical circuits safely and in accordance with accepted practice. **For safety’s sake,** if in doubt, please contact your dealer or the Service Department at Southworth Products Corp at (207) 878-0700 or (800) 743-1000.

Before servicing the lift, **read and understand this entire section and the section entitled “Operating Instructions.”**

### WARNING

Before working underneath the lift, always raise the lift and insert the maintenance chocks, as shown in Figure 1. Failure to do so may result in damage to the lift and severe personal injury!

If the lift will not raise:

### CAUTION

Do not continue to hold the “up” button for more than 2 or 3 seconds. You may damage the pump.

Check the actual weight of the load. The rated capacity of the lift is shown on the table skirt.

### WARNING

This power unit contains a hydraulic pump that is capable of developing excessive pressure. A pressure relief valve is used to set the pressure at the desired level. Tampering with, adjusting, modifying, or removing the relief valve is extremely dangerous and is not recommended. Only a trained hydraulics technician, using a calibrated hydraulic pressure gauge to assure the proper pressure setting is achieved, should make the adjustments to the relief valve.

If the motor is not running, check the main disconnect switch, the fuse(s) and the wiring to the motor.

Using an external lifting mechanism, such as a crane or fork lift, **raise the lift and insert the maintenance chocks as shown in Figure 1.** Be sure to lift the hinged end of the table top.

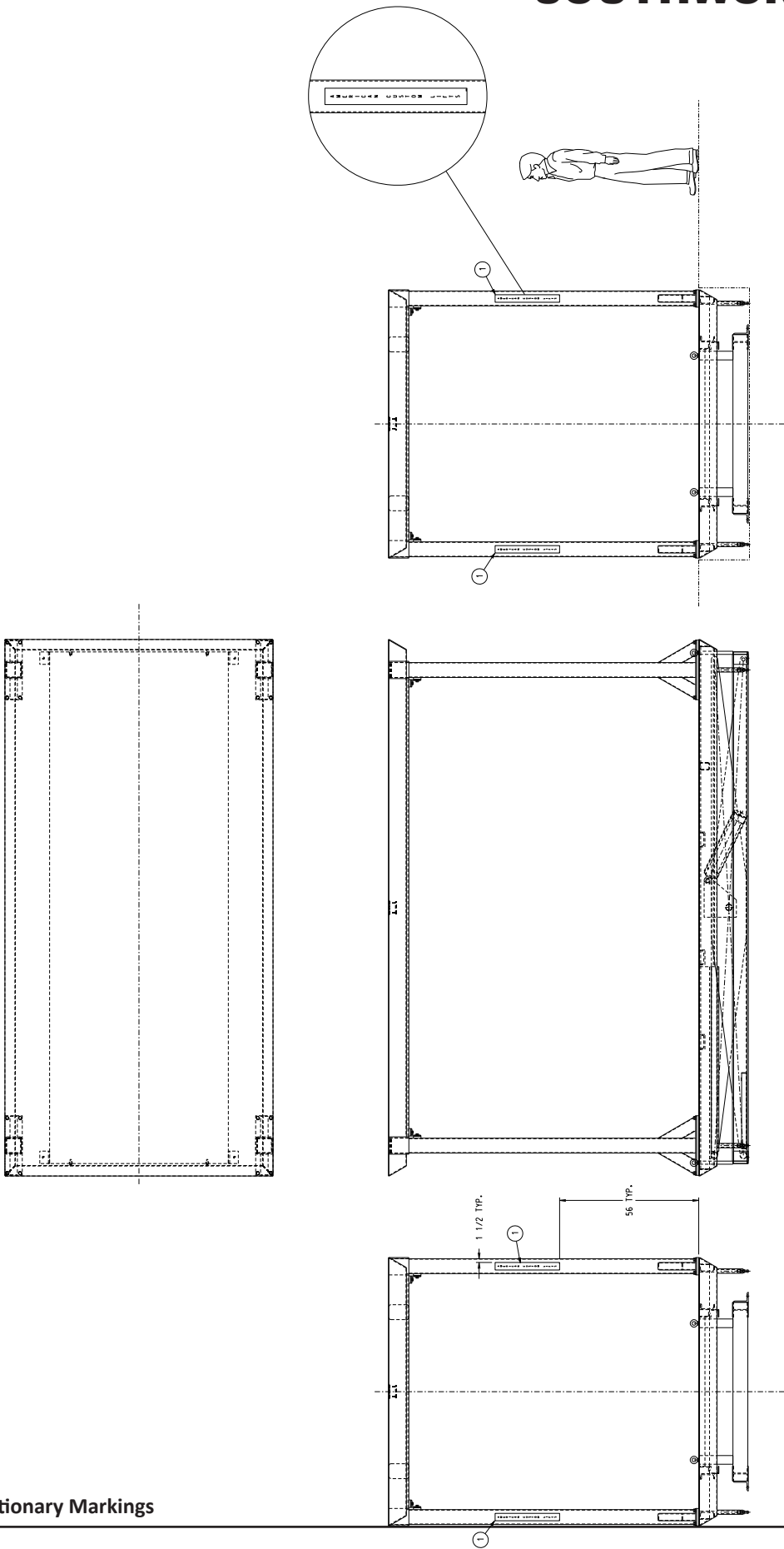

**Fig. 4 - Labels and Precautionary Markings**

## Phantom Park Lift

The hydraulic oil level may be low. When the lift is raised as far as possible, the oil should be about 3/4 inch above the bottom of the tank. (The exact level varies with different models.) Use a dipstick to check the oil level.

If your lift has an optional up limit switch, the lift may have reached this upper limit. If the switch is out of adjustment, the lift may not be able to raise completely. Readjust the switch if necessary.

### **⚠ WARNING**

**Do not disconnect the up limit switch. Instead, loosen the adjusting screw, and change the position of the arm. If you do disconnect the switch, when the lift platform moves up, it may not stop at the correct point. If the platform rises above the normal stopping point, the frame of the unit may be damaged. People working nearby may be hurt.**

On a lift with a three-phase motor, the motor may be running backwards. If the motor has been wired correctly, the lift should start moving 2 or 3 seconds after you press the “up” button. If it does not, try reversing any two electrical leads.

On a lift with a three-phase motor, the motor may be “single phasing.” When this happens, the motor hums, but does not turn. If this is the case, one lead of the three-phase line has been interrupted. Check the motor wiring and line fuses.

The motor voltage may be too low. Check the voltage at the starter when the motor is under load. The supply voltage should be within  $\pm 10\%$  of the rating.

On a lift with an external power unit, the tank vent may be plugged. You must remove the solid plug from the tank and insert the vented plug. The vent line must be clear.

The suction filter may be clogged. Clean the suction filter as described in the section on “Periodic Maintenance.”

A vacuum leak may be allowing air into the suction line, causing cavitation (loss of suction) in the pump. Check all fittings in the suction line, and repair as necessary.

### **⚠ CAUTION**

**If cavitation is allowed to continue, the pump may be damaged, and may have to be replaced.**

For the lift to raise, the down-valve must be de-energized and fully closed. Check for a problem with the wiring to the down-valve. Check the solenoid in the valve with a volt meter. The valve must be clean and free to operate. To check this,

remove the solenoid and then the valve. Look for contamination which could block the valve action. Clean the valve plunger with kerosene, then blow it clean with compressed air. The expansion nut which holds the solenoid should be finger tight only!

If the pump has been changed, the coupling may not have been installed. See the pump assembly in Figure 9.

If the lift elevates, but fails to hold a load:

**Raise the lift and insert the maintenance chocks, as shown in Figure 1.**

### **⚠ WARNING**

**Failure to chock the legs may result in damage to the lift and severe personal injury!**

The check valve may be leaking. Dirt on the valve seat will prevent the valve from closing fully. The check valve is mounted in the base of the pump housing, as shown in Figure 9. Remove the check valve cap and inspect the valve for contamination which may be preventing it from closing. You may be able to restore the seal by lightly rapping the ball into the seat using a 1/4” diameter rod and a small hammer.

The down-valve may be energized. While the lift is holding a load, the down-valve should be de-energized and fully closed. Check the solenoid in the valve with a volt meter. The valve must also be clean and free to operate. To check this, remove the solenoid and then the valve. Look for contamination which could block the valve action. Clean the valve plunger with kerosene, then blow clean with compressed air. The expansion nut which holds the solenoid should be finger tight only!

The cylinder(s) may be leaking. Look for oil on the cylinder rod(s) and in the vent line. (This may also occur if the oil tank has been overfilled.) If you find much oil in either place, and the tank is not overfilled, the cylinder(s) need to be repacked. See the instructions in this manual on “Repacking Southworth Lift Cylinders.”

**If the lift fails to lower:**

**1. Raise the lift and insert the maintenance chocks, as shown in Figure 1.**

### **⚠ WARNING**

**Failure to chock the legs may result in damage to the lift and severe personal injury!**

The down valve may be de-energized. When the lift is lowering, the down valve should be energized

and fully open. Check the solenoid in the valve with a volt meter. The valve must also be clean and free to operate. Remove the solenoid, then the down valve. Look for contamination which could block the valve action. Clean the valve plunger with kerosene, then blow it clean with compressed air. The strainer screen over the lower part of the plunger must be clean. See Figure 9. Before reassembling, depress the plunger manually several times to be sure it moves freely. The expansion nut which holds the solenoid should be finger tight only!

The flow control may need to be adjusted. The flow control must be partially open to allow the oil to return from the cylinder(s). It is important that you follow these steps when adjusting the flow control:

- **Raise the lift and insert the maintenance chocks, as shown in Figure 1.**
- If you want the lift to lower more slowly, turn the control clockwise up to  $1\frac{1}{4}$  turn at a time. If you want the lift to lower more quickly, turn the control counterclockwise up to  $1\frac{1}{4}$  turn. Do not move the control more than  $1\frac{1}{4}$  turn at a time.
- Remove the maintenance chocks, and check the speed as the table lowers.
- Every time you want to change the adjustment again, raise the table again and insert the maintenance chocks as shown in Figure 1.

**DANGER!**

**Do not try to adjust the flow control while pressing the "down" button. If you try this, the lift may drop suddenly, and you may be hurt.**

If the steps listed above do not solve the problem, please call the Service Department at Southworth Products: (207) 878-0700 or (800) 743-1000.

## Repacking Cylinders

This section will tell you how to repack a "J-style" cylinder, shown in Figure 6. This type of cylinder is exclusive to Southworth, and repacking kits are only available through Southworth. To order a repacking kit, please call the Parts Department at (207) 878-0700 or (800) 743-1000. When ordering, specify the model number and serial number of the lift, and the cylinder number(s), as stamped on the

base of the cylinder(s).

Before beginning this procedure, **read and understand this entire section.**

DL lifts usually have two or more cylinders. If the packing in one cylinder is worn, the packing should be replaced in all of the cylinders. This will prevent maintenance problems in the future. The repacking procedure is the same for each of the cylinders

**WARNING**

**Before working underneath the lift, always raise the lift and insert the maintenance chocks, as shown in Figure 1. Failure to do so may result in damage to the lift and severe personal injury!**

Before you disassemble the old cylinder, be sure you have these items on hand:

- A repacking kit. Parts may be damaged when you disassemble the cylinder. You should have replacement parts on hand so you can reassemble the lift and use it immediately.
- A supply of new hydraulic oil. Contaminated oil may damage the new packing.
- A container to catch the used oil.
- A clean place to work. Choose a place which will not be damaged if you spill some oil.

**Raise the lift and insert the maintenance chocks, as shown in Figure 1.**

Turn off electrical power at the main disconnect or circuit breaker, or unplug the machine. This will prevent the lift from moving accidentally while you are working on it.

Disconnect the cylinder supply line at the pump, and place the end into a container to collect the used oil.

Disconnect the vent line(s) at the cylinder(s).

At the top end of the cylinder rod, remove the "keeper," and drive out the clevis pin. Push the rod back into the cylinder to drive the hydraulic fluid out through the hose into the container. You may use air pressure at the vent hole to do this. Disconnect the hydraulic line(s) from the cylinder(s). Lift the cylinder(s) out of the lift. Be careful! Each cylinder is heavy!

Figure 6 shows the parts inside a J-style cylinder. At the upper end of the cylinder, remove the large snap ring. Pull the rod and piston all the way out of the cylinder. This assembly is heavy! Be careful not to drop it as it comes free.

Look for deformation around the hole at the clevis end of the cylinder rod. If necessary, clean up the

## Phantom Park Lift

rod diameter with a file to allow the rod bearing to slide off without damage.

Remove the plastic rod bearing from the cylinder rod. Observe how the wiper ring sits in the rod bearing. Remove the wiper ring and the O-ring from the rod bearing. Do not try to remove the aluminum piston from the cylinder rod, as this will damage the assembly. Loosen the small snap ring. Remove the poly U-cup from the piston.

Check the vent plug, and clean it if it appears dirty.

### CAUTION

**While reassembling, it is very important to keep all of the parts free of dirt, dust, metal chips, water, and other contamination. Most of the problems with hydraulic systems are caused by contamination in the oil.**

Clean the piston surfaces, and install a new fiber wear ring. Install a new poly U-cup seal, with the open part of the seal facing down.

Clean all of the surfaces on the rod bearing. Install a new O-ring and wiper. Replace the rod bearing assembly on the rod.

### CAUTION

**Be careful not to install the wiper backwards. The lip on the wiper should point upwards, as shown in the detail in Figure 6.**

Clean the bore of the cylinder tube thoroughly. Inspect the bore of the tube for scratches that run up and down, along the length of the cylinder. If you do see any scratches, hone the inner surface of the cylinder. Be sure to clean the tube thoroughly after you do this.

Lubricate the seal and piston with clean grease or oil. Carefully insert the piston and rod back into the cylinder. Be very careful not to pinch or tear the poly U-cup as the piston passes the shoulder inside the cylinder. It is helpful to tip the rod assembly and twist it as you slide it into the cylinder. Once the piston is inside the cylinder, it should slide easily.

### CAUTION

**If the poly U-cup is pinched or torn during reassembly, the piston may not maintain pressure as designed.**

Slide the rod bearing into the cylinder. Install a new snap ring to hold the rod bearing in place.

Install the cylinder(s) in the lift. Replace the clevis pin(s) and “keeper(s).” Reconnect all of the hydraulic lines and the vent line(s).

At the start of the packing process, you drained

the cylinder(s) into a container. Replace this used oil with an equal amount of fresh oil. Be sure to reinstall the vent plug when you're done.

Turn on the electrical power and press the “up” button. The pump will self-prime. After a few seconds, the cylinder should lift the table off the maintenance chocks. Remove the maintenance chocks. Cycle the lift up and down a few times to remove air pockets. Check for leaks.

Raise the lift and check the oil level with a dipstick. The oil should be about 3/4 inch above the bottom of the tank.

If you have spilled any oil, clean it up.

### DANGER

**Spilled hydraulic oil is slippery, and may present a fire hazard. Always clean up any spilled oil.**

## Replacing Leg Rollers

Please contact the Service Department at Southworth Products Corp for instructions for your model and application at (207) 878-0700 or (800) 743-1000.



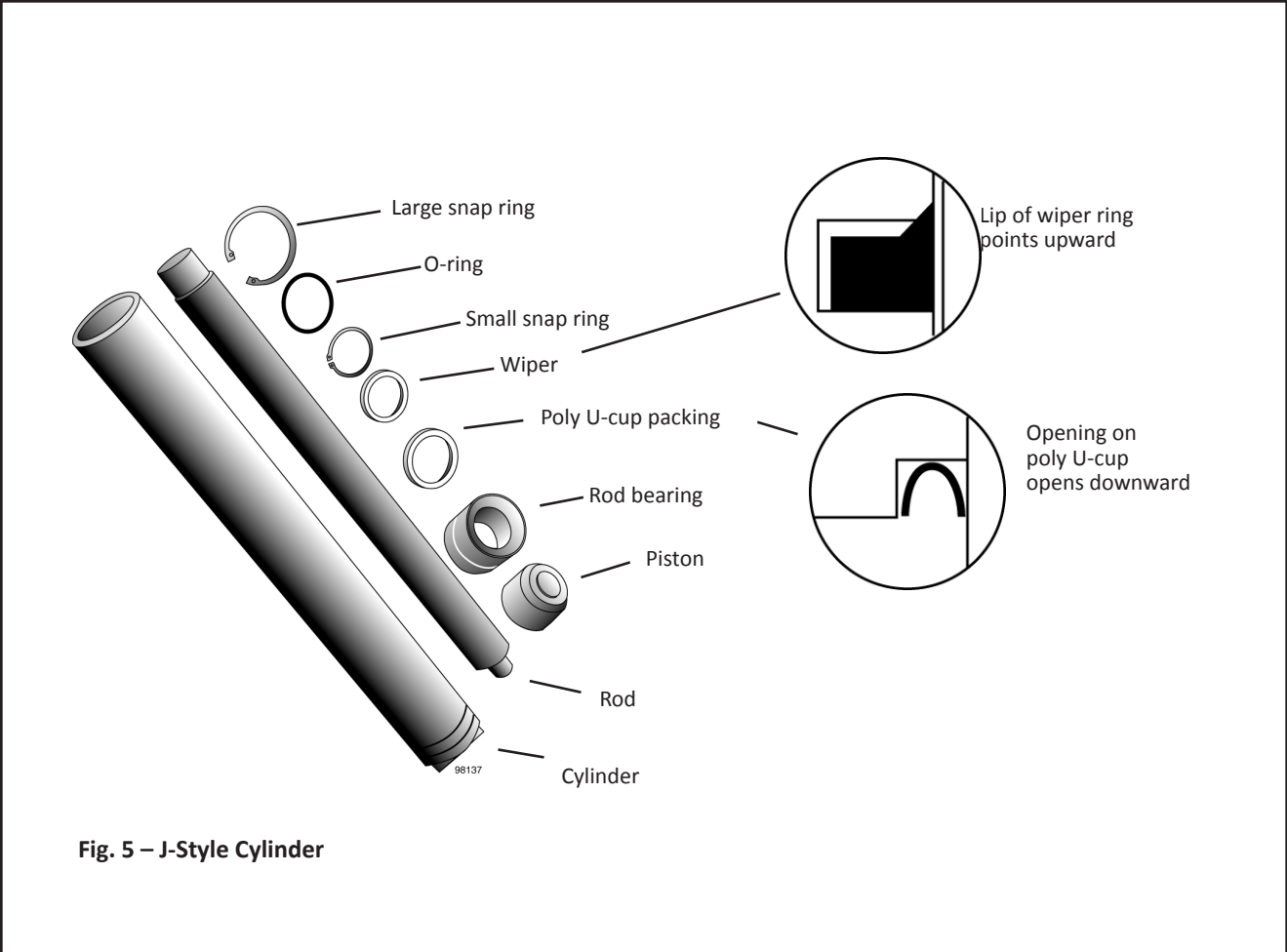

**Fig. 5 – J-Style Cylinder**

**Fig. 6– Parts Identification**

(lift shown without precautionary labels for clarity)



## Ordering Replacement Parts

Southworth has carefully chosen the components in your lift to be the best available for the purpose. Replacement parts should be identical to the original equipment. **Southworth will not be responsible for equipment failures resulting from the use of incorrect replacement parts or from unauthorized modifications of the machine.**

Southworth can supply all replacement parts for your Southworth lift. Key parts are identified in Figures 9 through 11. With your order, please include the model number and the serial number of the lift. You may find these numbers on the name plate, which is located on the crossbar at the base of the cylinder(s). When you are ordering parts for a cylinder, also include the cylinder number. This is stamped on the base of the cylinder housing.

To order replacement parts, please call the Parts Department at (207) 878-0700 or (800) 743-1000. Parts are shipped subject to the following terms:

- FOB factory
- Returns only with the approval of our Parts Department.
- Payment Net 30 days (except parts covered by warranty).
- Freight collect (except parts covered by warranty).
- The warranty for repair parts is 30 days from date of shipment.

Parts replaced under warranty are on a “charge-credit” basis. We will invoice you when we ship the replacement part, then credit you when you return the worn or damaged part, and we verify that it is covered by our warranty. Labor is not covered under warranty for Parts orders.

Parts Department  
Southworth Products Corp  
Telephone: (207) 878-0700  
(800) 743-1000  
FAX : (207) 797-4734

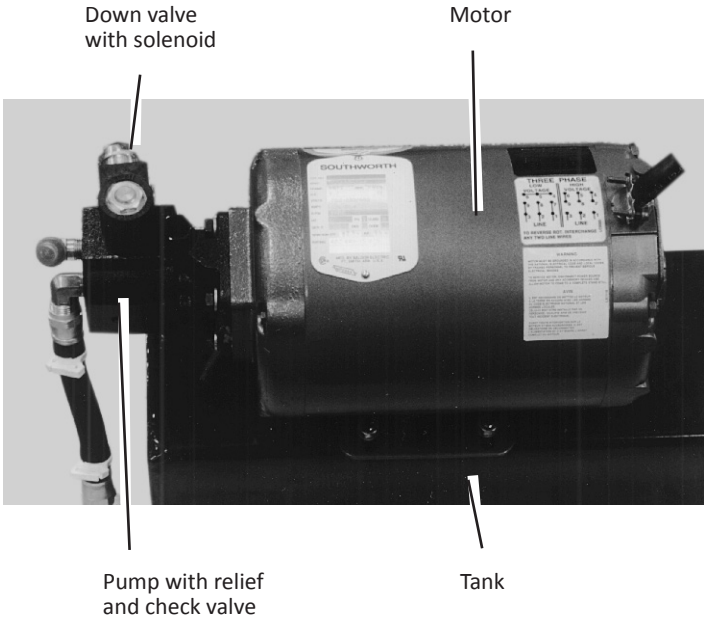

**Fig. 7 – Standard 3.2 HP Power Unit**

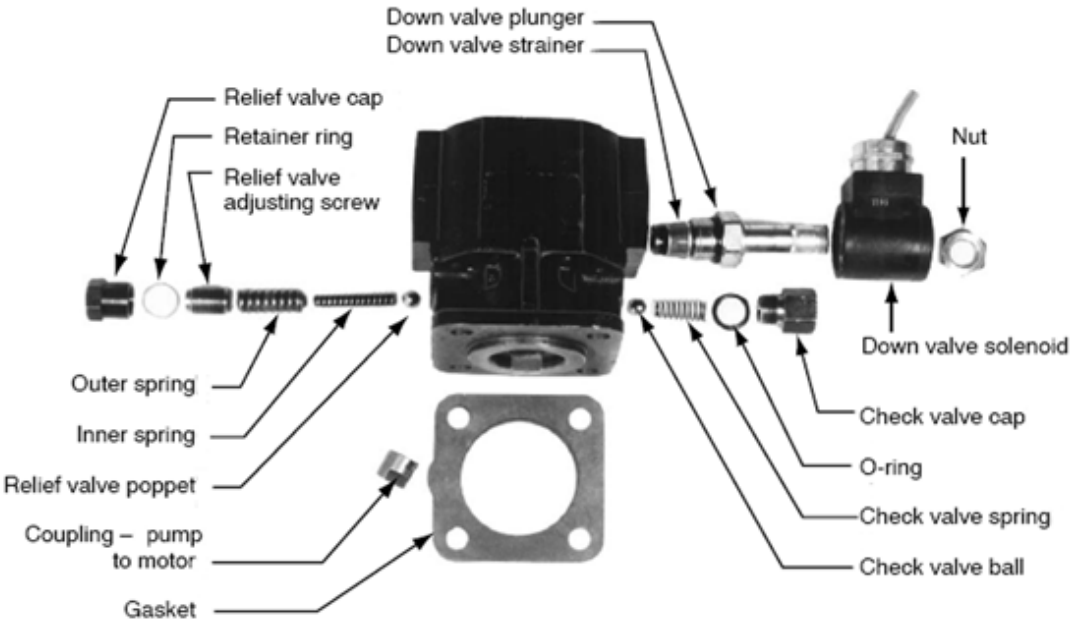

**Fig. 8 – Hydraulic Pump and Down Valve**

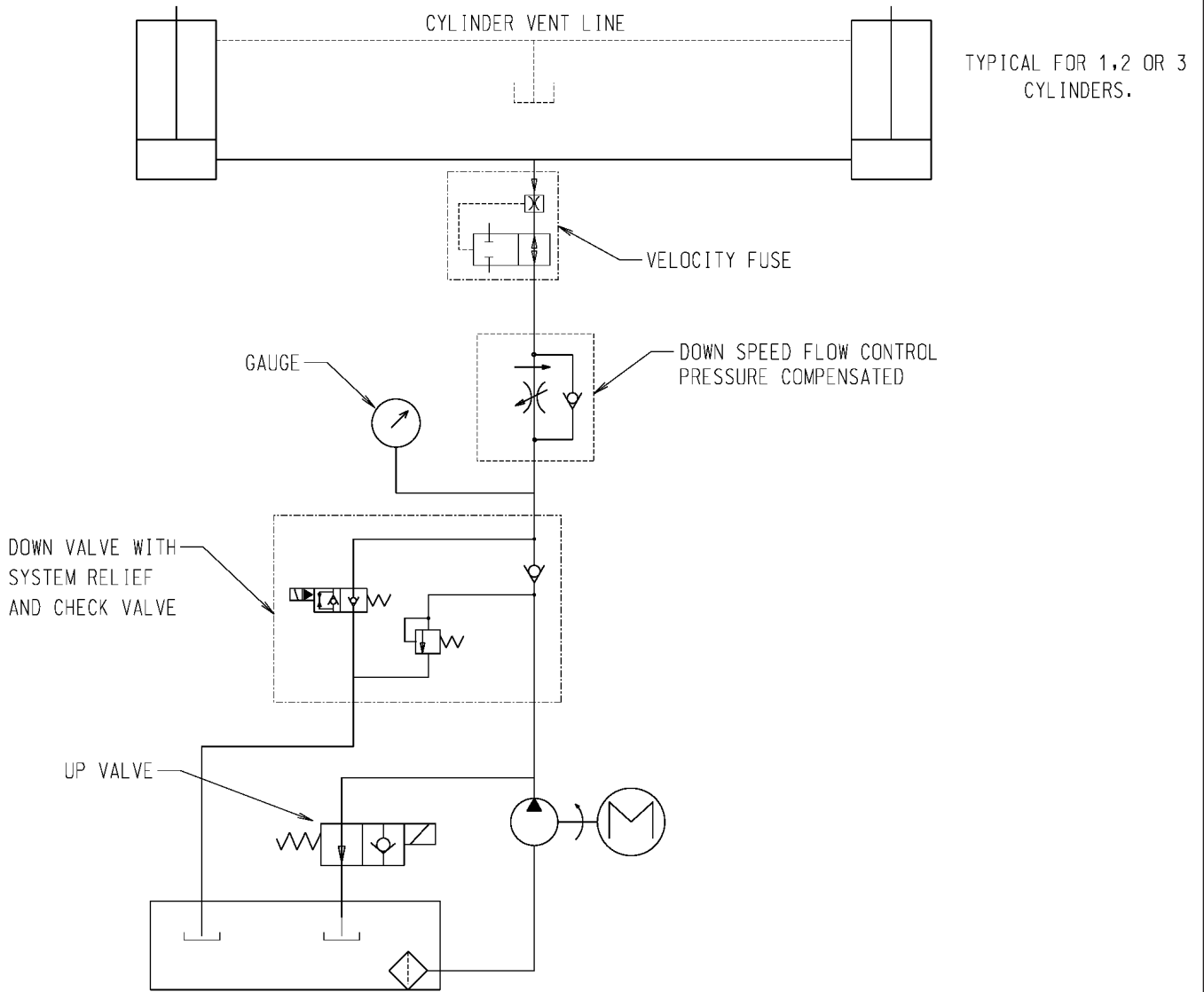
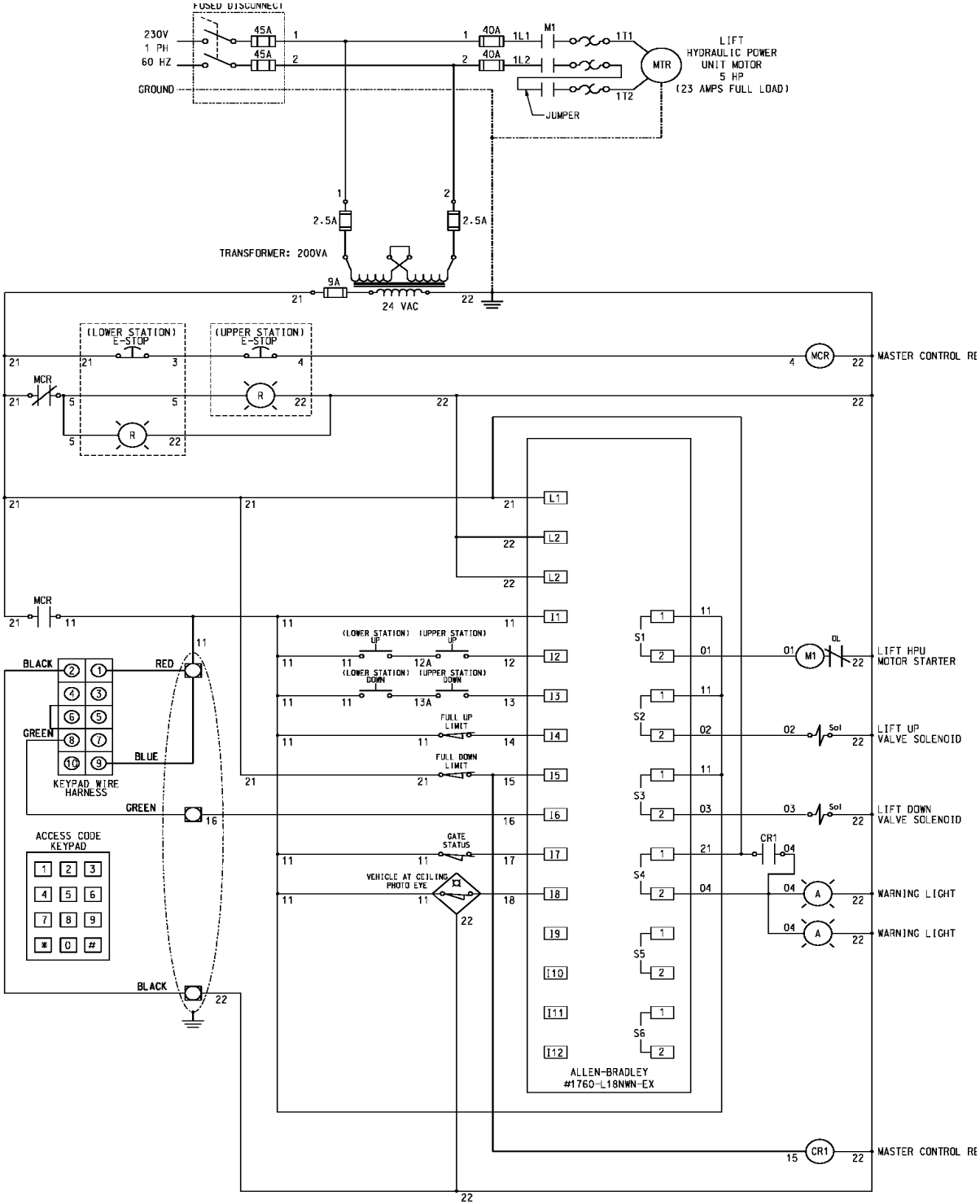

Fig. 9 -- Hydraulic Schematics



NOTE:  
IF GATES ARE NOT PRESENT, ADD A JUMPER BETWEEN WIRES 11 AND 17

**Fig. 10 -- Wiring Diagram**

CABLE CLASS	LENGTH	WIRES	VOLTAGE	CONDUIT & CABLE SCHEDULE	USAGE	SPARE WIRES	WIRES
P0	BY INSTALLERS	2 - #16 RED (W/N) 1 - #8 GRN (W/N)	230 VAC		INCOMING POWER TO MAIN CONTROL PANEL	0	G11, L2
F1	BY INSTALLERS	2 - #8 BK (W/N) 1 - #8 GRN (W/N)	230 VAC		MOTOR WIRING	0	G11, L1, L2
C1	BY INSTALLERS	2 - #16 RED (W/N) 1 - #8 GRN (W/N)	24 VAC		VALVE WIRES	0	G20, G22
C2	BY INSTALLERS	4 - #16 RED (W/N) 1 - #16 GRN (W/N)	24 VAC		LIME SWITCH WIRES	0	G11, L1, L2, L1
C3	BY INSTALLERS	2 - #16 RED (W/N) 1 - #16 WHI (W/N) 1 - #16 GRN (W/N)	24 VAC		CEILING PROTECTION SENSOR	0	G11, L8, L2
C4	BY INSTALLERS	1 - #16 RED (W/N) 1 - #16 WHI (W/N) 1 - #16 GRN (W/N)	24 VAC		UPPER LEVEL WARNING BEACON	0	G4, G22
C5	BY INSTALLERS	2 - #16 RED (W/N) 1 - #16 WHI (W/N) 1 - #16 GRN (W/N)	24 VAC		UPPER LEVEL STOP STATION	0	G3, G5, L1, L2, L3, L4, L5, L6, L7, L8, L9, L10, L11, L12, L13, L14, L15, L16, L17, L18, L19, L20, L21, L22
C6	BY INSTALLERS	1 - #16 RED (W/N) 1 - #16 WHI (W/N) 1 - #16 GRN (W/N)	24 VAC		LOWER LEVEL WARNING BEACON	0	G4, G22
C7	BY INSTALLERS	SHIELDED CABLE - #16ZZ (W/N)	24 VAC		LOWER LEVEL LEYPAD	0	SHIELD, L1, L2, L3
C8	BY INSTALLERS	1 - #16 RED (W/N) 1 - #16 WHI (W/N) 1 - #16 GRN (W/N)	24 VAC		LOWER LEVEL PROHIBITION STATION	0	G3, G5, L1, L2, L3, L4, L5, L6, L7, L8, L9, L10, L11, L12, L13, L14, L15, L16, L17, L18, L19, L20, L21, L22
C9	BY INSTALLERS	1 - #16 RED (W/N) 1 - #16 WHI (W/N) 1 - #16 GRN (W/N)	24 VAC		UPPER LEVEL WIRING	0	G3, G5, L1, L2, L3, L4, L5, L6, L7, L8, L9, L10, L11, L12, L13, L14, L15, L16, L17, L18, L19, L20, L21, L22
C10	BY INSTALLERS	2 - #16 RED (W/N) 1 - #16 WHI (W/N) 1 - #16 GRN (W/N) SHIELDED CABLE	24 VAC		LOWER LEVEL OPERATOR INTERFACE WIRES	0	G3, G5, L1, L2, L3, L4, L5, L6, L7, L8, L9, L10, L11, L12, L13, L14, L15, L16, L17, L18, L19, L20, L21, L22

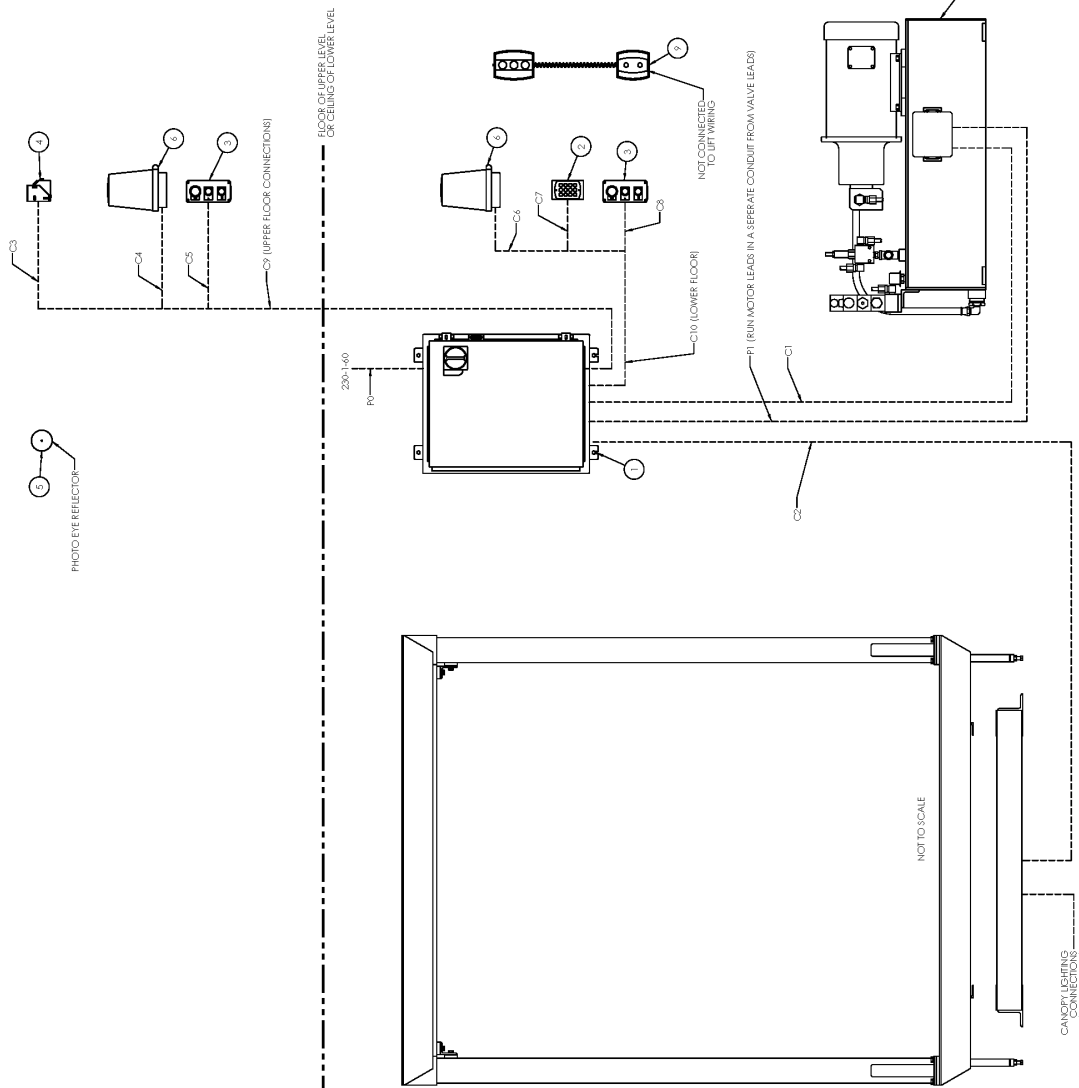

Fig. 11 -- Electrical Arrangement

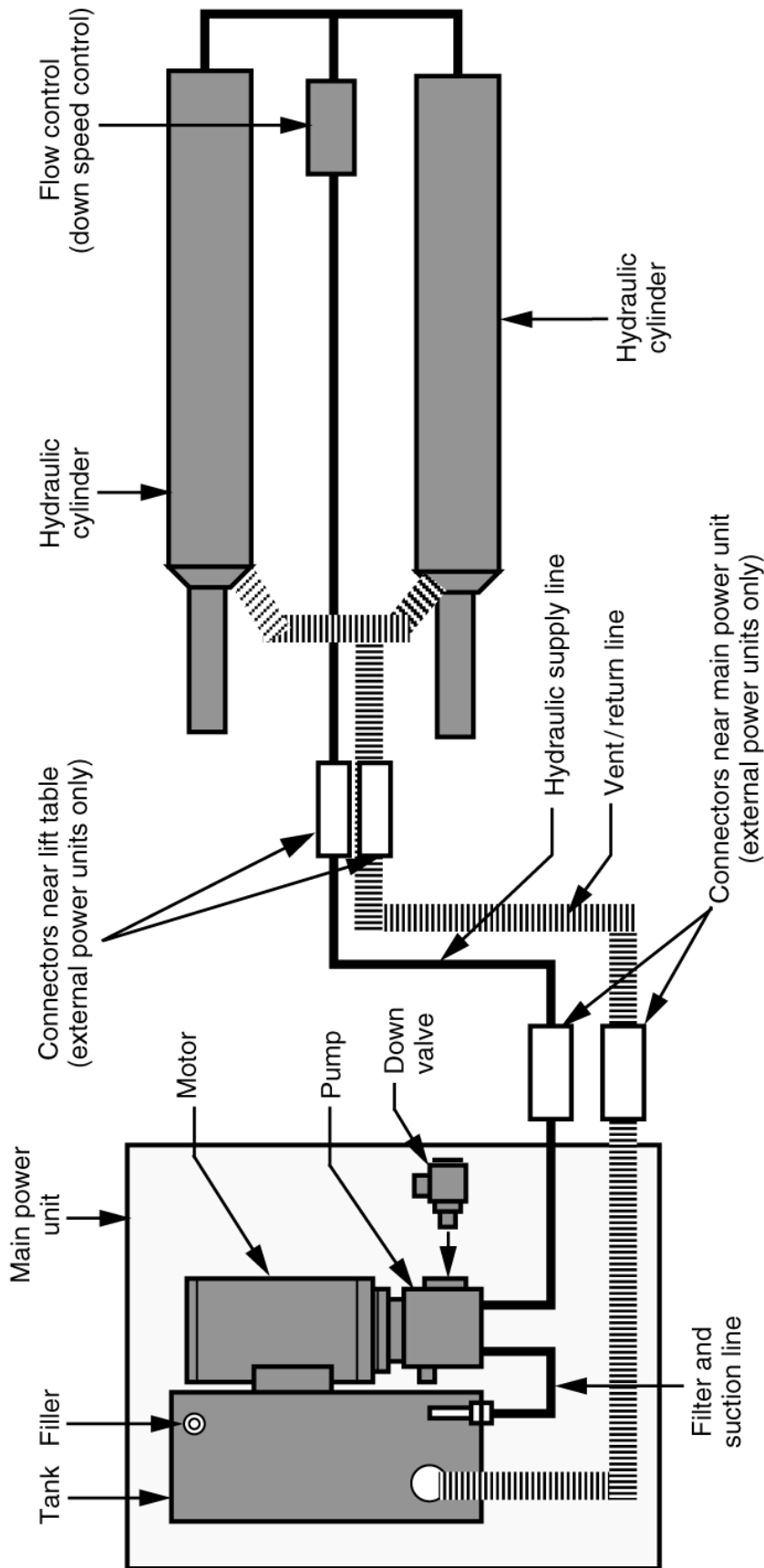

Fig. 12 – Hydraulic Connections

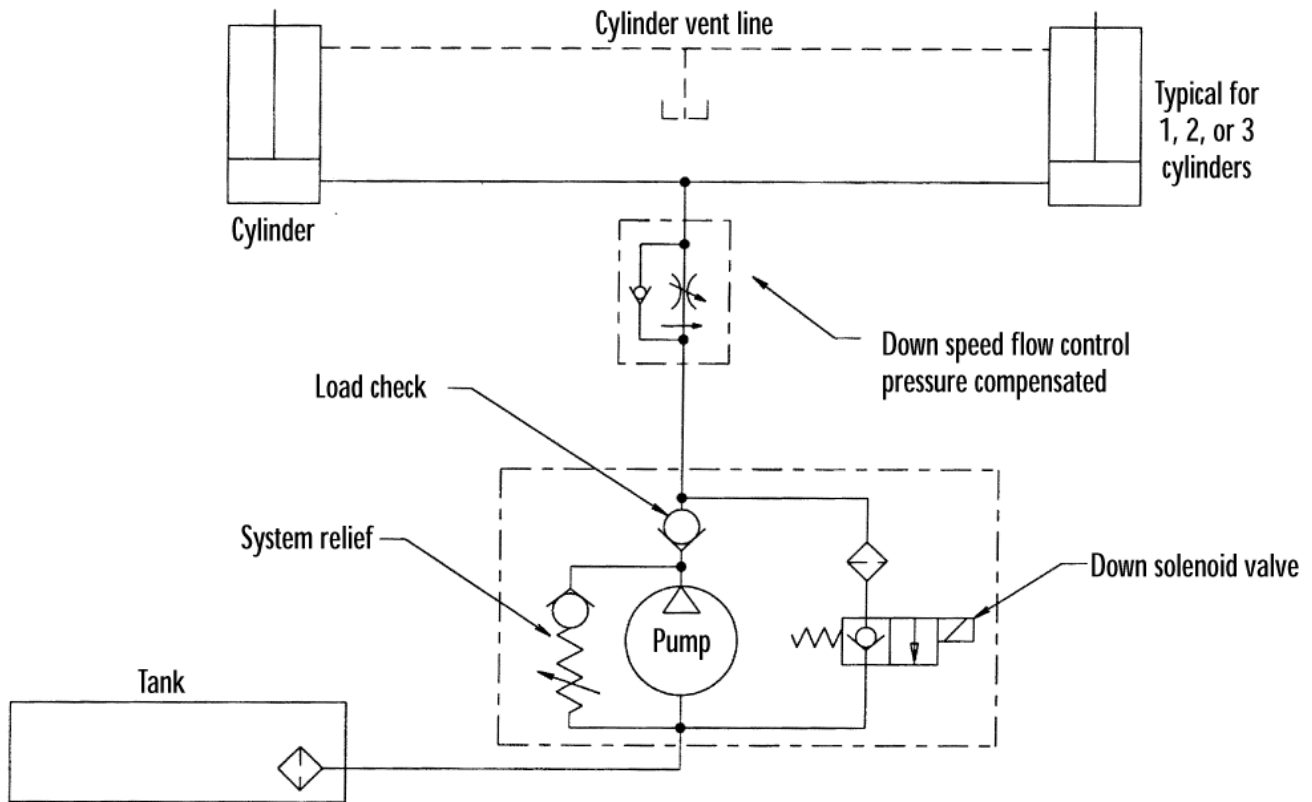

Fig. 13 – Hydraulic Diagram

**Table 1 – Hydraulic Oil Specifications**

If the lift will be used at normal ambient temperatures, Southworth supplies the unit with Citgo AW 32 oil. This may be replaced by any other good quality oil with 150 SSU at 100° F and rust and oxidation inhibitors and anti-wear properties. If the lift will be used at ambient temperatures below 0°F, use aircraft hydraulic oil. Use Type 15 aircraft hydraulic oil.

The following are equivalent to CITGO AW32:

TYPE .....	MANUFACTURER
DTE 24 .....	EXXON/MOBIL
NUTO H32 .....	EXXON/MOBIL
AMOCO AW32 .....	CHEVRON (AMOCO CO.)

**CAUTION**

It is very important to keep the hydraulic oil free of dirt, dust, metal chips, water, and other contamination. Most of the problems with hydraulic systems are caused by contamination in the oil.



## ONE YEAR WARRANTY

Southworth Products Corp warrants this product to be free from defects in material or workmanship for a period of (1) one year of single shift usage from date of shipment, providing claim is made in writing within that time period. This warranty shall not cover modified designs for special applications, failure or defective operation caused by misuse, misapplication, negligence or accident, exceeding recommended capacities, failure to perform required maintenance or altering or repairing, unless alteration is authorized by Southworth Products Corp. Except as set forth herein, there are no other warranties, express or implied, including the warranties of merchantability and fitness for a particular purpose, all of which are hereby excluded.

Southworth Products Corp makes no warranty or representation with respect to the compliance of any product with state or local safety or product standard codes, and any failure to comply with such codes shall not be considered a defect of material or workmanship under this warranty. Southworth Products Corp shall not be liable for any direct or consequential damages arising out of such noncompliance.

Southworth Products Corp's obligation under this warranty is limited to the replacement or repair of defective components at its factory or another location at Southworth Products Corp's discretion. The Southworth Warranty is for product sold with in North America. For products shipped outside of North America the warranty will be for replacement of defective parts only. Labor is not included. This is buyer's sole remedy. Except as stated herein, Southworth Products Corp will not be liable for any loss, injury or damage to persons or property, nor for direct, indirect, or consequential damage of any kind, resulting from failure or defective operation of said product.

This warranty may be altered only in writing by Southworth Products Corp, Portland, Maine.

**SOUTHWORTH**

**SOUTHWORTH PRODUCTS CORP**  
P.O. Box 1380, Portland, ME 04104-1380  
Telephone: (800) 743-1000 • (207) 878-0700  
Fax: (207) 797-4734  
[www.SouthworthProducts.com](http://www.SouthworthProducts.com)

# **SOUTHWORTH**

**making work faster, safer, and easier**

Southworth is the world class supplier of products designed to improve productivity and enhance safety. Our staff has over 400 years of engineering experience. If one of our standard products does not meet your needs, our engineers can custom design equipment specifically suited to your material handling application.



**Spring PalletPal Load Leveler**



**Lift with Flush Mount Turntable**



**Portable Container Tilters**



**Dock Lifts**



**Roll on Level Loaders**



**Portable Lifts**



**Stack-n-Go Powered Stacker**



**Floor Height Lifts  
Roll-E**

**Floor to  
Mezzanine Lifts**



**Pallet Rotators**



**For more information, contact Southworth Products**

Telephone (800) 743-1000 Fax (207) 797-4734

**Email: [salesinfo@SouthworthProducts.com](mailto:salesinfo@SouthworthProducts.com)**