

# SOUTHWORTH

---

## Heavy Duty Dock Lift Owner's Manual (DL10/12/16/20 - 59H)



Model:  
Serial Number:  
Date placed in  
service:

SOUTHWORTH PRODUCTS CORP.  
P.O. Box 1380, Portland, ME 04104-1380  
Telephone: 800-743-1000 • 207-878-0700  
Fax: 207-797-4734  
[www.SouthworthProducts.com](http://www.SouthworthProducts.com)

# Contents

<b>1</b>	<b>Introduction.....</b>	<b>4</b>
1.1	Responsibilities of Owner and Users.....	4
1.2	Responsibilities of Operators.....	5
<b>2</b>	<b>Safety.....</b>	<b>7</b>
2.1	Safety Alert Symbols.....	7
2.2	Signal Words.....	7
2.3	Safety Devices.....	7
<b>3</b>	<b>Labeling.....</b>	<b>7</b>
3.1	Label Location Diagram.....	8
<b>4</b>	<b>Installation.....</b>	<b>9</b>
4.1	External Power Unit.....	9
4.2	Pit Installation.....	9
4.3	Pit Plan.....	10
4.4	Pad Plan.....	11
4.5	General Installation.....	12
<b>5</b>	<b>Operation.....</b>	<b>14</b>
5.1	Loading.....	15
<b>6</b>	<b>Maintenance &amp; Repair.....</b>	<b>15</b>
6.1	Maintenance Devices.....	16
6.2	Periodic Maintenance.....	17
6.2.1	Weekly Maintenance.....	17
6.2.2	Monthly Maintenance.....	17
6.2.3	Six Months.....	17
6.3	Relieving Hydraulic Pressure.....	18
6.4	Replacement Parts.....	19
<b>7</b>	<b>Troubleshooting.....</b>	<b>19</b>
<b>8</b>	<b>Electrical Information.....</b>	<b>21</b>
8.1	Wiring Schematic.....	21
8.2	Control Panel.....	22
<b>9</b>	<b>Hydraulic Information.....</b>	<b>23</b>
9.1	Hydraulic Fluid Specifications.....	23
9.2	Hydraulic Schematic.....	23
9.3	Hydraulic Power Unit.....	23
9.4	Hose Specifications.....	24
9.5	Hydraulic Arrangement.....	24
<b>10</b>	<b>Warranty &amp; Contact Information.....</b>	<b>25</b>

 **WARNING**

Cancer and Reproductive Harm -  
[www.P65Warnings.ca.gov](http://www.P65Warnings.ca.gov)

10095524

This label (Part No. 10095524) is required by California law.  
For more information visit: [www.P65Warnings.ca.gov](http://www.P65Warnings.ca.gov)

**NOTICE**

This lift is design and manufactured in accordance with  
ANSI standard MH29.1 – “The Safety Requirements for  
Industrial Scissors Lifts”.

# 1. Introduction

Southworth Products' Heavy Duty Dock Lift is a highly customizable machine. This manual covers the configurations considered standard and can not cover all possible configurations. For specific information about options or configurations not covered in this manual contact customer service.

**Read and understand this manual before installing, operating, or performing and maintenance/repair**

## 1.1 Responsibilities of Owner and Users

**Basic Principles** - Owners/users shall apply sound principles of safety, training, inspection, maintenance, and expected operating environment. It shall be the responsibility of the owner/user to advise the manufacturer where deflection may be critical to the application.

**Manuals** - Owners/users shall keep and maintain a copy of the operating and maintenance manual(s) and ensure its availability to operating and maintenance personnel.

**Inspection and Maintenance** - It shall be the responsibility of the users to inspect and maintain the industrial scissors lift as required to ensure proper operation. The frequency of inspection and maintenance shall be based upon the manufacturer's recommendations and be compatible with operating conditions and the severity of the operating environment. Machinery that is not in proper operating condition shall be immediately removed from service until repaired. Maintenance and repairs shall be made by a qualified person and the repairs shall be in conformance with the manufacturer's recommendations.

**Maintenance Safety Precautions** - Before adjustments and repairs are started on the machine, the following precautions shall be taken as applicable:

1. Remove the load from the load enclosure.
2. Lower the platform to the full down position if possible or secure by maintenance device and/or blocking as described by the manufacturer to prevent unintended platform movement.
3. Relieve system pressure from all circuits before loosening or removing any components.
4. All controls in the "off" position and all operating features secured from inadvertent motion by brakes, blocks, or other means.
5. Disconnect power and follow established owner/user lockout/tag out policies.
6. Follow precautions and directions as specified by the manufacturer.

**Replacement Parts** - When parts or components are replaced, they shall be replaced with parts or components approved by the original manufacturer.

**Maintenance Training** - The user shall ensure only qualified personnel inspect and maintain the machine in accordance with the manufacturers recommendations.

**Operator Training** - An owner/user, who directs or authorizes an individual to operate the machine shall ensure that the individual has been:

1. Trained in accordance with the manufacturer's operating manual.
2. Made aware of the responsibilities of operators as outlined in section 1.4 of this manual.
3. Retrained, if necessary, based on the owners/user's observation and evaluation of the operator.

**Modifications** and additions shall not be performed without the manufacturer's prior written approval. Where such authorization is granted, capacity, operation, and maintenance instruction plates, tags, or decals shall be changed accordingly.

## 1.2 Responsibilities of Operators

**Basic Principles** - Operators shall apply sound principles of safety and good judgment in the application and operation of the machine with consideration given to its intended use and expected operating environment. Since the operator is in direct control of the machine, conformance with good safety practices is the responsibility of the operator. The operator shall make decisions on the use and operation with due consideration for the fact that his or her own safety as well as the safety of other personnel on or near the machine is dependent on those decisions.

1. **General Training** - Only personnel who have received general instructions regarding the inspection, application and operation of machine, including recognition and avoidance of hazards associated with their operation, shall operate the machine. Such topics covered shall include, but not necessarily be limited to, the following issues and requirements:
  2. A pre-start inspection
  3. Responsibilities associated with problems or malfunctions affecting the operation of the machine.
  4. Factors affecting stability
  5. The purpose of placards and decals
  6. Workplace inspection
  7. Safety rules and regulations
  8. Authorization to operate
  9. Operator warnings and instructions
  10. Actual operation of the machine. Under the direction of a qualified person, the trainee shall operate the machine for a sufficient period of time to demonstrate proficiency in actual operation of the machine.

**Pre-start Inspection** - Before use each day or at the beginning of each shift, the machine shall be given a visual inspection and functional test including but not limited to the following:

1. Operating and emergency controls
2. Safety devices
3. Hydraulic system leaks
4. Electrical cables and wiring harness
5. Loose or missing parts
6. Nameplates, precautionary and instructional markings and/or labeling
7. Guarding system
8. Items specified by the manufacturer

**Problem or Malfunctions** - Any problems or malfunctions that affect the safety of operations shall be repaired prior to the use of the machine.

**Before Operations** - The operator shall:

1. Read and understand the manufacturer's operating instruction(s) and user's safety rules or have them explained
2. Understand all labels, warnings, and instructions displayed on the machine or have them explained.

**Workplace Inspections** - Before the machine is used and during use, the operator shall check the area in which the machine is to be used for possible hazards such as, but not limited to:

1. Bumps, floor obstructions and uneven surfaces
2. Overhead obstructions and electrical hazards
3. Presence of unauthorized persons
4. Other possible unsafe conditions as noted in the operating manual.

**Operator Warnings and Instructions** - The operator shall ensure the operation of the machine is in compliance with the following:

**Guarding system** - Guarding shall be installed and positioned, and access gates or openings shall be secured per the manufacturer's instructions.

**Distribution of load** - The load and its distribution on the platform shall be in accordance with the manufacturer's rated capacity for that specific configuration.

**Maintaining overhead clearance** - The operator shall ensure that adequate clearance is maintained from overhead obstructions and energized electrical conductors and parts.

**Point of Operation** - The operator shall not place any part of their body under the platform.

**Precaution for moving equipment** - When other moving equipment or vehicles are present, special precautions shall be taken to comply with the safety standards established for the workplace.

**Reporting problems or malfunctions** - The operator shall immediately report to a supervisor any problem(s) or malfunction(s) that become evident during operation. The operator shall ensure all problems and malfunctions that affect the safety of operations are repaired prior to continued use.

**Capacity limitation** - Rated capacity shall not be exceeded when loads are transferred to the load enclosure.

**Work area** - The operator shall ensure the area surrounding the machine is clear of personnel and equipment before lowering the load enclosure.

**Securing the machine** - The operator shall comply with the means and procedures provided to protect against use by an unauthorized person(s).

**Altering safety devices** - Safety devices shall not be altered or disabled.

**Modifications** or alterations of the machine or the fabrication and attaching of frameworks or the mounting of attachments to the machine or the guarding system shall only be accomplished with prior written permission of the manufacturer.

**Assistance to the operator** - If an operator encounters any suspected malfunction or any hazard or potentially unsafe condition relating to capacity, intended use or safe operation the operator shall cease operation of the machine and request further instruction from the owner/user.

**Problems or malfunctions** - Any problem(s) or malfunction(s) that affect the safety of operations shall be repaired prior to the use of the machine.

## 2. Safety

All personnel installing, operating, and maintaining this machine shall read and understand this manual. For questions or concerns contact the manufacturer.

This machine shall be installed, operated, and maintained by trained and/or qualified personnel only.

If this machine is to be installed in a pit it must have guarding in compliance with ANSI MH 29.1. Section 4.11.1 Pit Mounted Installations.

### 2.1 Safety Alert Symbols

A symbol that indicates a hazard. It is composed of an equilateral triangle surrounding an



exclamation mark. The safety alert symbol is only used on hazard alerting signs. It is not used on safety notice and safety instructions signs.

**A** – For use with **DANGER** signal word; (safety white triangle, safety red exclamation mark, safety red background)

**B** – For use with **WARNING** signal word; (safety black triangle, safety orange exclamation mark)

**C** – For use with **CAUTION** signal word; (safety black triangle, safety yellow exclamation mark)

**D** – For use with **DANGER, WARNING, or CAUTION** signal words; (safety yellow triangle with a safety black border and safety black exclamation mark)

### 2.2 Signal Words



Indicates a hazardous situation that, if not avoided, will result in death or serious injury.



Indicates a hazardous situation that, if not avoided, could result in death or serious injury.



Indicates a hazardous situation that, if not avoided, could result in minor or moderate injury.



Indicates information considered important, but not hazard-related (e.g., messages relating to property damage).

### 2.3 Safety Devices

This machine is equipped with devices and features to protect the operator and nearby personnel from severe injury or death. These features and devices shall be installed and functioning correctly during operation.

## 3. Labeling

This machine has labeling to indicate potential hazards this machine may pose when operating and/or maintaining the machine. All labels must be legible. If any label is missing, damaged, or otherwise illegible contact the manufacturer for replacement labels.

### 3.1 Label Location Diagram



CUT AND DISCARD OFF LAST PANEL OF 5904643

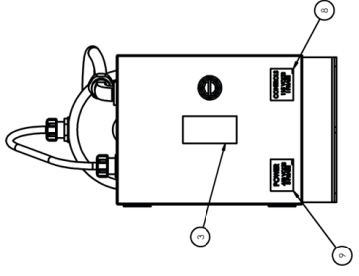
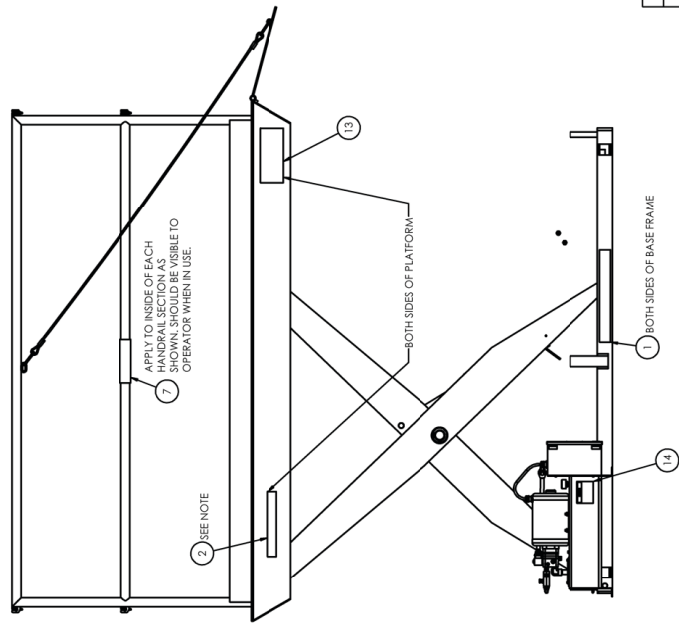
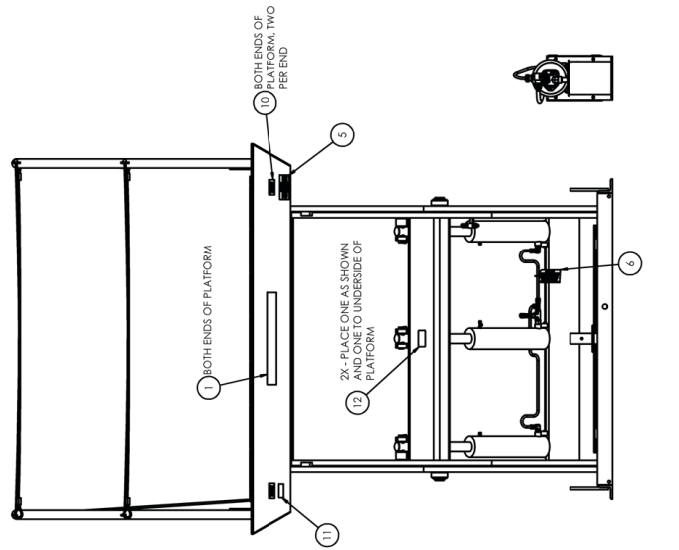

ITEM NO.	QTY.	DESCRIPTION	PART NO.
14	1	BK-LD DCL 1.500X5.50 TANK TO BE FULL ONLY	2986997
13	2	BK-LD TAG SOUTHWORHTH	5900158
12	2	LD DCL 2.00X3.00 SERIAL ID BL	1007929
11	1	LD WARNING CANCER AND REPRODUCTIVE	10095524
10	4	BK-LD DCL 1.25X2.75 CAPACITY	
9	1	BK-LD DCL 1.25X1.75 POWER.	
8	1	BK-LD DCL 1.25X1.75 CONTROL.	
7	2	LD DCL 2.00X8.00 DO NOT OPERATE WITHOUT	10086440
6	1	LD DCL 2.50X5.00 PROPER INSTALLATION IS	2998365
5	1	BK-LD DCL 2.00X4.50 NOTICE! DO NOT RAISE	2921026
4	4	BK-LD DCL 1.00X3.00 FOR MAINTENANCE ONLY	2991927
3	1	BK-LD DCL 3.00X1.50 ARC FLASH AND SHOCK	10047672
2	2	BK-LD DCL 2.00X12.00 A DANGER	5904643
1	4	BK-LD DCL 2.00X17.00 TO AVOID BODILY INJ	2986306

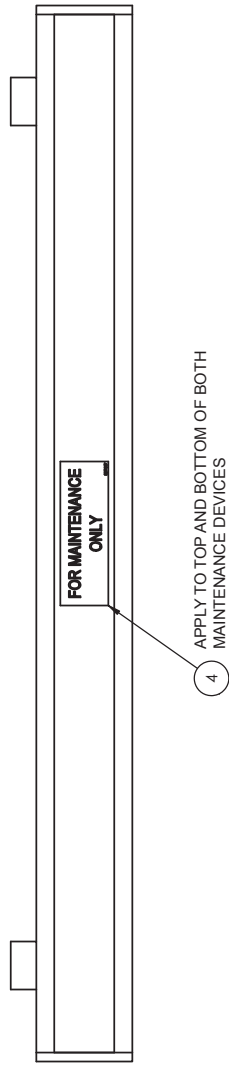



## 4. Installation

Installation of this machine shall be performed by trained and/ or qualified personnel only. The owner/ installer is responsible obtaining any necessary permissions and/ or permits. Follow all applicable codes and ordinances. Read and understand all safety and installation information in this manual.

**Before installation**, remove all shipping materials and verify all components on the packing list were received. Inspect the machine, all components, wiring and electrical connections, hydraulic hoses and fittings for damage. If components are missing or damage is found contact the manufacturer before continuing installation. If not being installed in a pit see Pad Plan section.

**⚠ WARNING** To avoid death or serious injury:

- Pinch points and Crush Hazards exist when moving and transporting the machine. Do not enter under any equipment while moving or transport. Keep hands, feet, and loose clothing away from moving equipment.
- This machine must be installed on a solid, stable, level surface or machine will be unstable and can lead to injury. Do not install on asphalt or other unstable surface.
- Never enter beneath the platform unless the machine is unloaded and secured against lowering using the maintenance device. See Maintenance Devices section.

**⚠ DANGER** High Voltage: Electrical service and installation must be performed by trained and/ or qualified personnel. Lock-out/ tag-out the power source before installation.

Electric motors create sparks. Do not install the power unit in an area where flammable gases may be present.

All electrical components and the hydraulic power unit must be protected from wet and/or dirty environments unless specifically configured for such environments.

### **NOTICE**

Use appropriate lifting device to lift the machine. Use a load spreader to lift the machine. Lift the machine using the provided lifting eye-bolts only. Do not lift the machine by the platform.

This machine must be properly anchored before operation or the machine may be damaged.

### 4.1 External Power Unit

External power units should be placed within thirty feet (hose length) of the machine to avoid excess pressure drops. Longer distances can cause increased rise and lower times.

### 4.2 Pit Installation

**⚠ WARNING** Do not install this machine in a pit unless the machine has been designed for such installation. Shear points exist and can cause severe injury. Platforms traveling below floor level require guarding in accordance with ANSI MH 29.1 section 4.11.1 Pit Mounted Installations. Guarding must be installed before operation.

1. Verify that the pit dimensions match the pit plan.
2. Verify that pit is clear of tools and other debris before lowering the machine into the pit.
3. Follow General Installation instructions to complete the installation.

### 4.3 Pit Plan

3" X 3" X 1/4" ANGLE BY PIT CONTRACTOR. ALL CORNERS TO BE SECURELY WELDED. PIT MUST BE SQUARE ( $\pm 1/2"$ ) ACROSS CORNERS.

CONDUIT ENTRY CAN BE FROM ANY DIRECTION INCLUDING ENTRY FROM BOTTOM OF PIT SUMP.

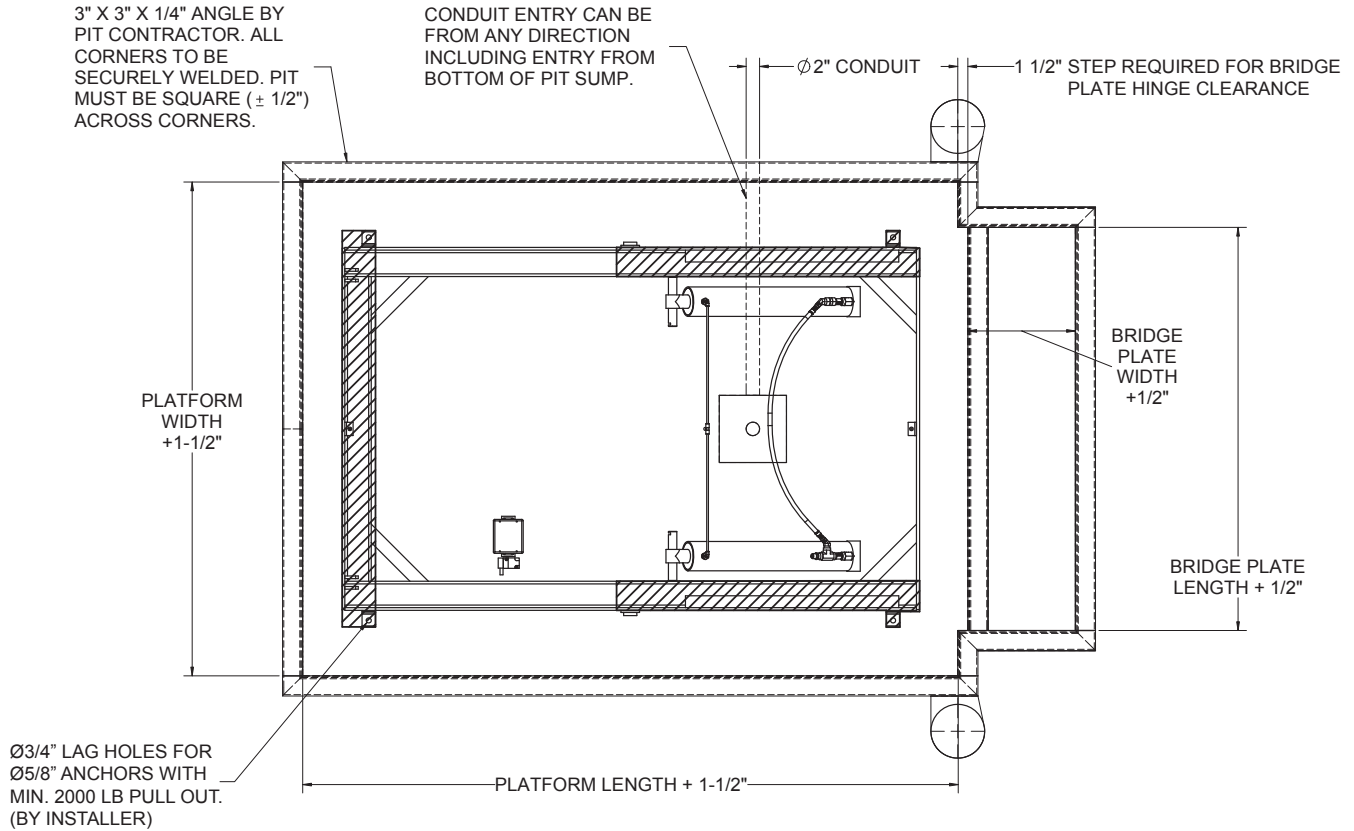

- CROSS HATCHING INDICATES AREAS OF BASE FROM THE MUST BE SHIMMED AND OR GROUTED AFTER LEVELING OF THE BASE FRAME TO ENSURE PROPER BASE FRAME SUPPORT.
- CONDUIT RUN IS REQUIRED FOR ROUTING OF HYDRAULIC HOSES AND ELECTRICAL WIRING UNLESS ALTERNATIVE ARRANGEMENTS ARE REQUESTED.
- $\phi 2"$  ELECTRICAL CONDUIT USED WHEN 1/2" HYDRAULIC HOSE, VENT LINE, AND ELECTRICAL LEADS ARE TO BE INSTALLED FROM POWER UNIT TO LIFT (BY PIT CONTRACTOR).

CONCRETE ANCHORS TO BE  $\phi 1/2"$  X 6" LOCATED 12" O.C. WITH ONE 3" FROM EACH END.

CONCRETE BEHIND CURB ANGLES MUST BE WELL COMPACTED WITH NO VODIS

1/2" SHIM UNDER EACH LAG PLATE FOR PROPER DRAINAGE

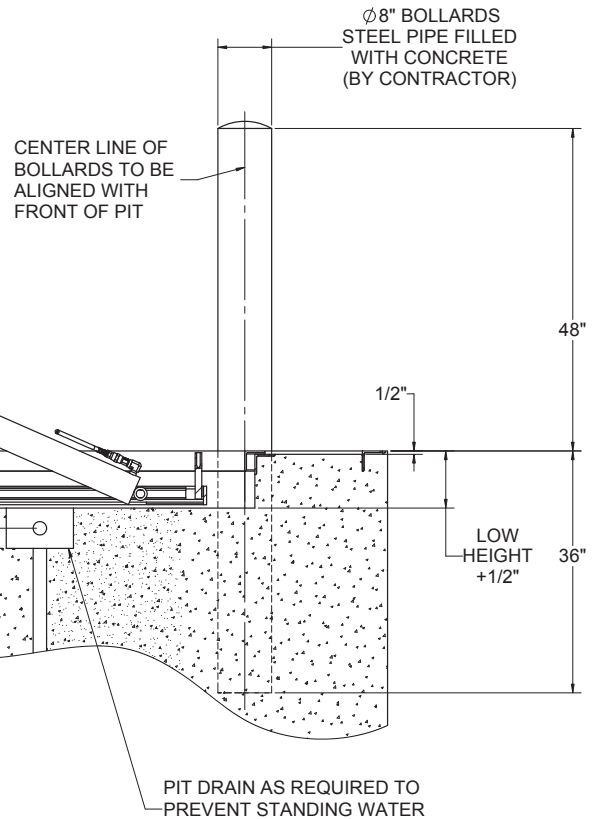

## 4.4 Pad Plan

Use of a sump/drain for proper drainage and a conduit run for hydraulic/ electrical routing in pad is recommended. If machine is installed on a pad, the standard 18"x 60" throw-over plate will not reach the ground and can not be used as a ramp.

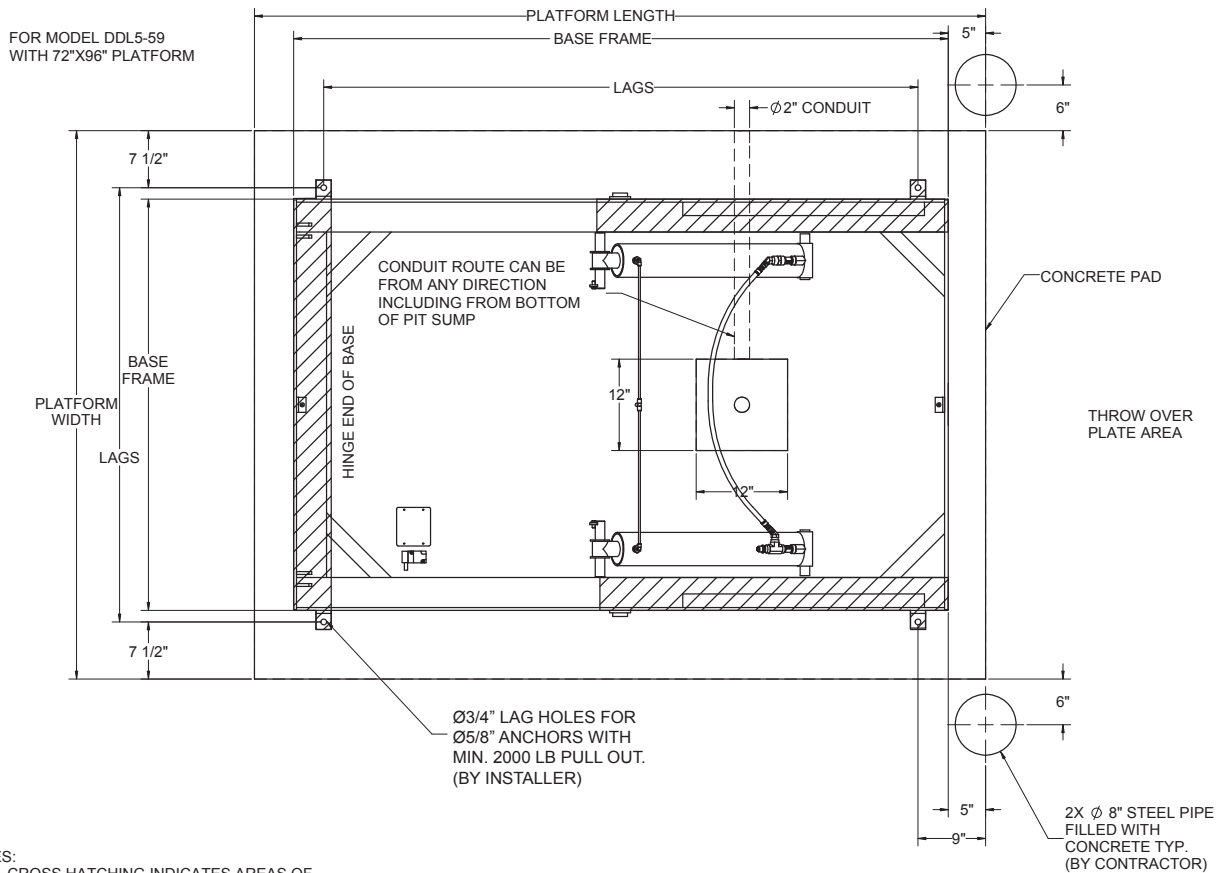

### NOTES:

- CROSS HATCHING INDICATES AREAS OF BASE FRAME THAT MUST BE SHIMMED AND/OR GROUTED AFTER LEVELING OF THE BASE FRAME TO ENSURE PROPER BASE FRAME SUPPORT.
- CONDUIT RUN IS RECOMMENDED FOR ROUTING OF HYDRAULIC HOSES AND ELECTRICAL WIRING.
- Ø2" ELECTRICAL CONDUIT USED WHEN 1/2" HYDRAULIC HOSE, VENT LINE, AND ELECTRICAL LEADS ARE TO BE INSTALLED FROM POWER UNIT TO LIFT (BY CONTRACTOR).

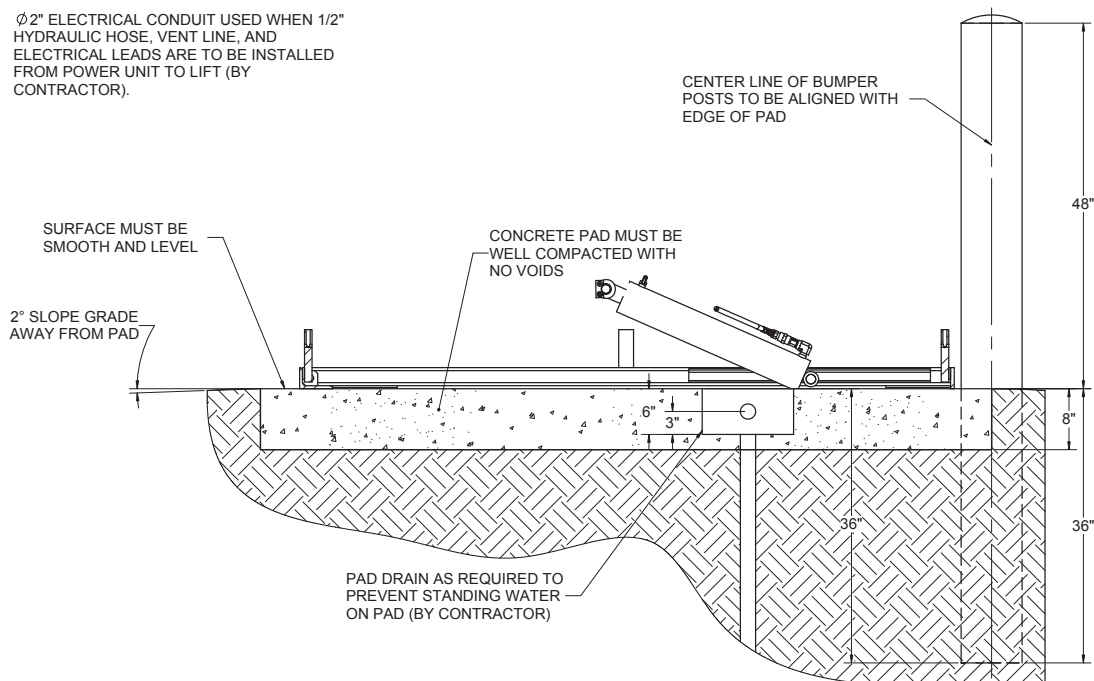

## 4.5 General Installation

1. Attach a chain or lifting strap, with an appropriate load spreader, to each lifting eye. The chain or strap must pull on the lifting eyes vertically. Ensure lifting eyes are threaded into the blocks welded to the base frame. Check shipping documentation for weight of machine.

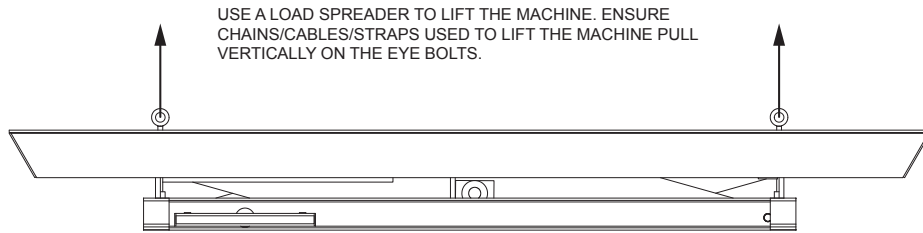

2. Using an appropriate lifting device, carefully move the machine into position.
3. Unscrew each eye bolt from the blocks securing the platform to the base. Do not remove eye bolts completely. The nut and washer are used to manually raise the platform. Always pull vertically on the lifting eyes.

### NOTICE

**Eye bolts must be removed from holes securing the platform to the base frame before attempting to raise the platform.**

4. Attach lifting chains/cable/straps to each eye bolt, slowly raise the platform high enough to engage the maintenance device. Engage the maintenance devices. **See the Maintenance Devices section.** Ensure the roller end of the platform is not lifted off of the upper rollers.
5. Remove the eye bolts and save them for future use, if needed.
6. Once the platform has been raised and the maintenance chocks have been engaged verify the pins at the base of the hydraulic cylinders are properly seated.

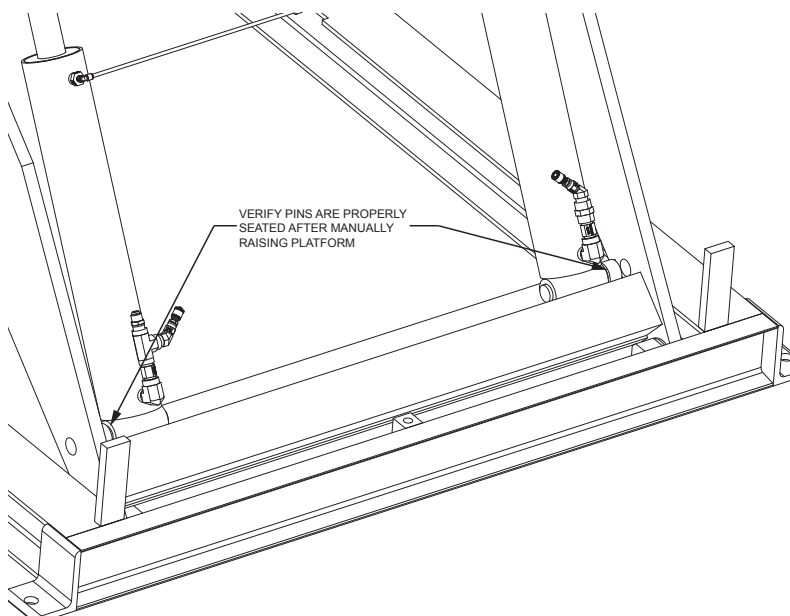
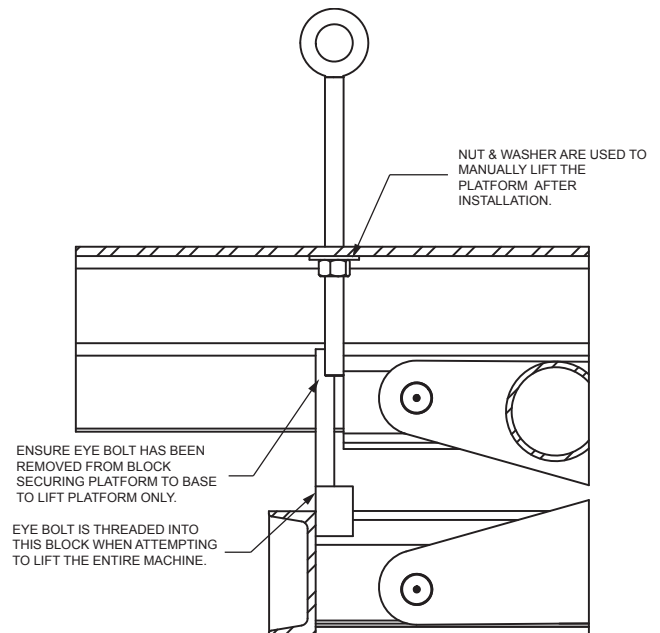

7. Ensure the machine is level. If necessary use shims beneath the lag plates. All load bearing points of the base frame must be fully supported by using grout and/or shims beneath the base frame after leveling.

**NOTICE**

**An improperly supported base frame can cause excess wear and/or permanent damage to the machine.**

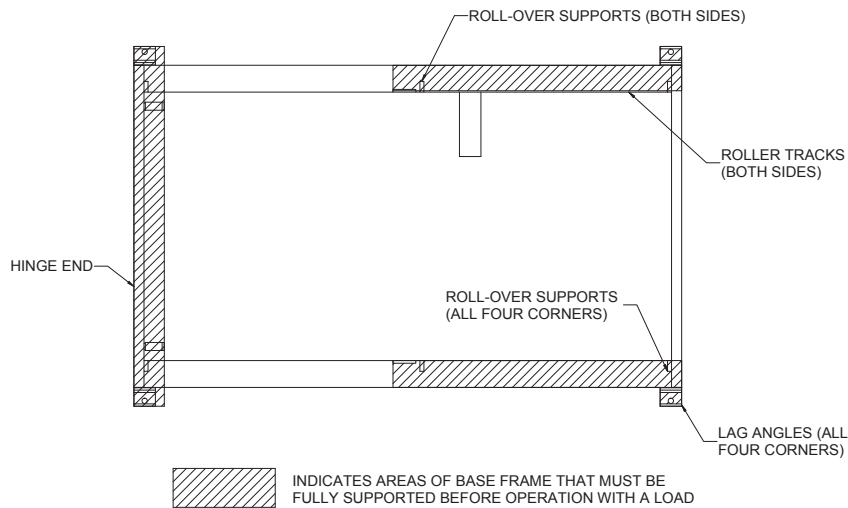

8. Anchor the machine using appropriate anchors.
9. Clear the hydraulic lines by flushing with compressed air.

**NOTICE**

**Hydraulic lines must be clear of debris before connecting or damage may occur when the unit is powered.**

**If hoses & electrical wiring are not routed through conduit, hoses and wiring must be protected from damage by other means.**

10. Make all hydraulic connections according the hydraulic schematic. Remove the plug from the reservoir and thread the vent line elbow in. – **See Hydraulic Information section for specifications and schematics.**
11. Make all electrical connections according the wiring schematic.– **See Electrical Information section for specifications and schematics.**

**Typical required connections during installation shown here.**

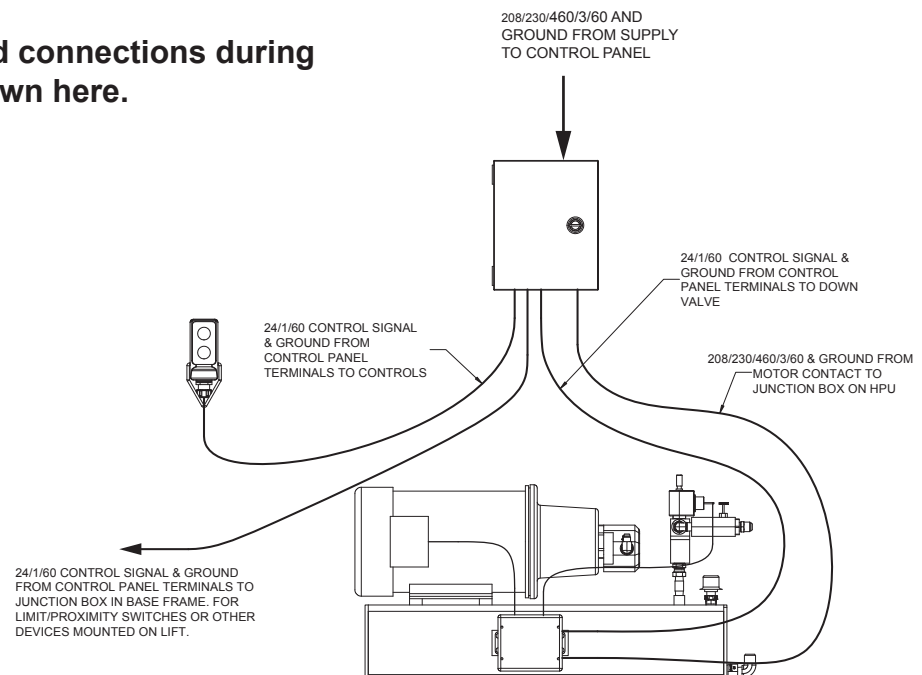

12. If applicable, install and anchor ramp.
13. Install handrails and snap cables/ chains.
14. Check all hydraulic hoses and connections, wiring and electrical connections, and other components for proper installation and damage.
15. Cycle the lift to test function. If platform does not begin to raise after a few seconds, **see Troubleshooting section.**

**NOTICE**

**Other platform configurations may be used. All instructions still apply.**

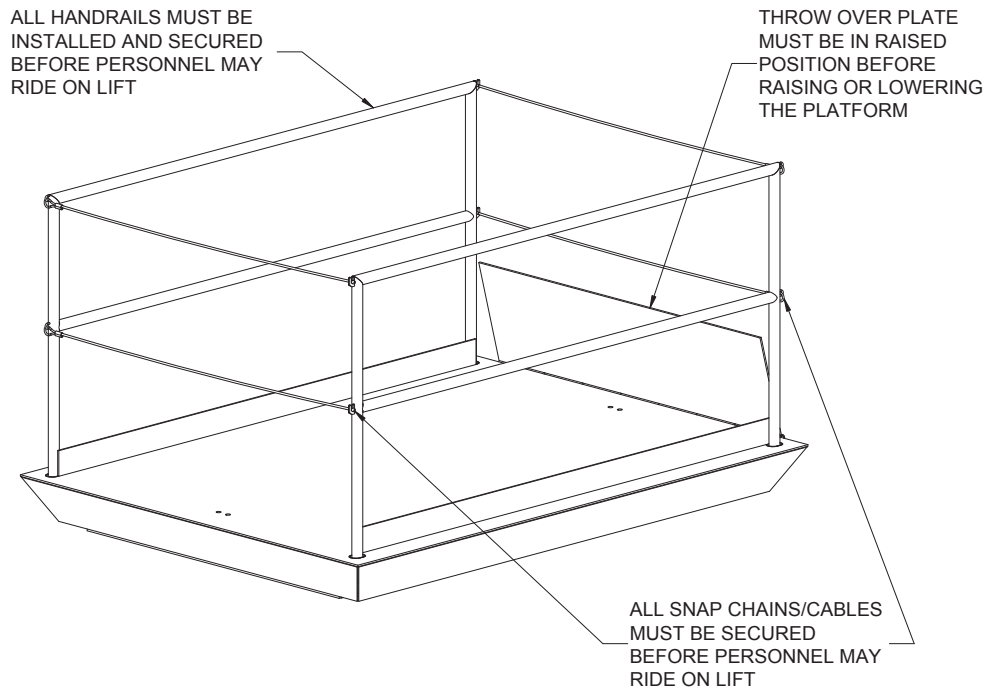

## 5. Operation

**Before operating** this machine, read and understand this manual. Inspect the machine for excessive wear and/ or damage. **If excessive wear or damage is found, remove the machine from service and contact maintenance personnel.** Inspect all precautionary labeling. If any label is missing or illegible contact the manufacturer for replacement labels. Ensure area is free of debris.

**NOTICE**

**Before raising or lowering, raise throw over plate(s) and bridge plate(s) to avoid damaging the plate(s).**

**⚠ WARNING**

To avoid death or serious injury:

- Only trained and/or qualified personnel shall operate this machine.
- Personnel are not permitted on the platform during operation unless handrails and snap chains/cables are installed.
- Loads that may shift during operating must be secured before operating.
- Keep hands, feet, and loose clothing away from moving parts.
- Do not enter beneath the platform until the load has been removed and the machine has been secured against lowering with the maintenance device(s).
- Do not load or unload the machine while moving.
- The load's center of mass must be centered on the platform. Uneven or off center loading may cause excessive wear or permanent damage.
- During operation, operator must be in view of the machine at all times.

**NOTICE**

When not in use, the platform is to be in the fully lowered position.

For standard push button/foot switch controls:

**To raise the machine**, press and hold the UP button on the controls. Release the button when the platform is at the desired height.

**To lower the machine**, press and hold the DOWN button on the controls. Release the button when the platform is at the desired height.

If machine is equipped with controls other than standard, contact Customer Service.

## 5.1 Loading

All loads should be centered on the platform. Uneven loading can lead to excessive wear or damage. Always secure loads that may roll or shift during travel.

## 6. Maintenance & Repair

**⚠ WARNING**

To avoid death or serious injury:

- Only trained and/ or qualified personnel shall perform maintenance or repair of this machine.
- Pinch points exist, keep hands, feet, and loose clothing away from moving parts.
- Always use appropriate Personal Protective Equipment when performing and maintenance or repair.
- Disconnect and lock out electrical supply before performing any maintenance or repair
- Do not adjust the hydraulic pressure relief valve. This valve is pre-set and adjustment may cause the machine to fail.
- Before performing maintenance or repair to the hydraulic components, relieve pressure in the hydraulic system. See Relieving Hydraulic Pressure section.
- Pressurized fluids can penetrate skin and cause severe injury. Do not use hands or other body parts to detect hydraulic leaks.
- Do not enter beneath the platform until the load has been removed and the machine is secured against lowering with the maintenance device(s). See Maintenance Devices section.

## NOTICE

All electrical components and the hydraulic power unit must be protected from wet and/or dirty environments unless specifically configured for such environments.

### 6.1 Maintenance Devices

**⚠ DANGER** To avoid death or serious injury:

- **DO NOT** enter beneath the platform until load has been removed and the machine is secured against lowering using the supplied maintenance device(s).
- The supplied maintenance device(s) are designed to support the weight of an **UNLOADED** machine only. Failure to remove the load before engaging the maintenance devices may result in failure and allow the machine to fall unexpectedly.

**Before performing any maintenance or repair:**

1. Remove any load on the platform of the machine.
2. Verify that all personnel and debris are clear of the work area.
3. Raise the lift to the fully raised position.
4. Engage maintenance device as shown in the diagram.
5. Slowly lower the machine until the weight of the machine is supported by the maintenance device(s). Continue to hold the down button for five to ten seconds after the platform stops to relieve hydraulic system pressure.
6. Disconnect electrical supply and lock out the machine to prevent unintended actuation of the machine.
7. After maintenance or repair is complete, verify all tools, debris, and personnel are clear of the area. Clean up any spills. Re-energize the machine.
8. Raise the machine to the fully raised position.
9. Disengage the maintenance device and stow the maintenance device.
10. Lower the machine to the fully lowered position.
11. Test for proper operation.

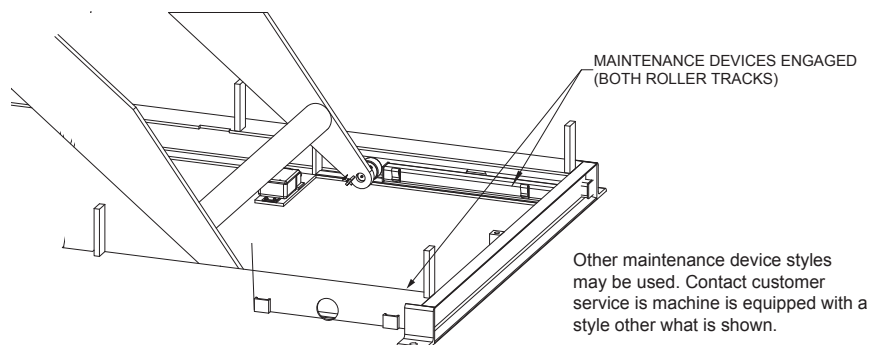
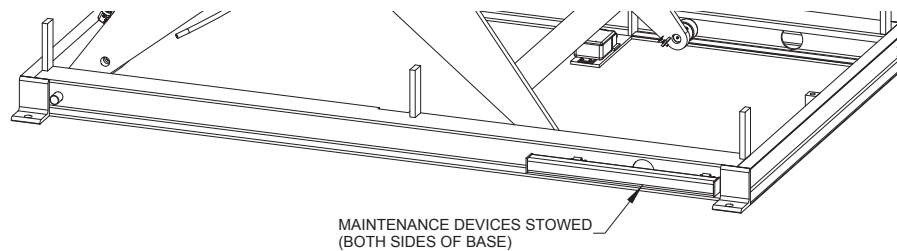



## 6.2 Periodic Maintenance

Before each use ensure area is clear of debris and sump/drain is clear. Inspect the machine for excessive wear or damage and ensure all precautionary labeling is legible. Inspect railings, verify cables/chains are in place and in good condition. Verify push button switch and cord are functioning and are not damaged.

### 6.2.1. Weekly Maintenance

- Inspect leg rollers, center pivot pins and bushings, and leg hinge pins and bushings for excessive wear or damage. Repair or replace as necessary.
- Inspect machine for loose or broken fasteners. Repair or replace as necessary.
- Inspect labeling. If any label is damaged or otherwise illegible contact the manufacturer for replacement labels.

### 6.2.2. Monthly Maintenance

- Perform Weekly Maintenance.
- Apply a light oil or PTFE lubricant to non-greased pivot points or rollers.
- Inspect the appearance of the hydraulic fluid. The fluid should be transparent and clear of debris.
- Inspect all hydraulic hoses and fittings. Repair or replace as necessary.
- Inspect all electrical wiring and connections. Repair or replace as necessary.
- Inspect control switches and cord, limit switches, if applicable. Repair, replace, or adjust as necessary.

### 6.2.3. Six Months

- Perform Monthly and Weekly maintenance.
- Inspect the hydraulic cylinder and return line. If excessive fluid exists in the vent line, the cylinder may need to be repacked or replaced.
- Change hydraulic fluid. Clean the suction screen and vent cap. Replace pressure line or return line filter element (if equipped).

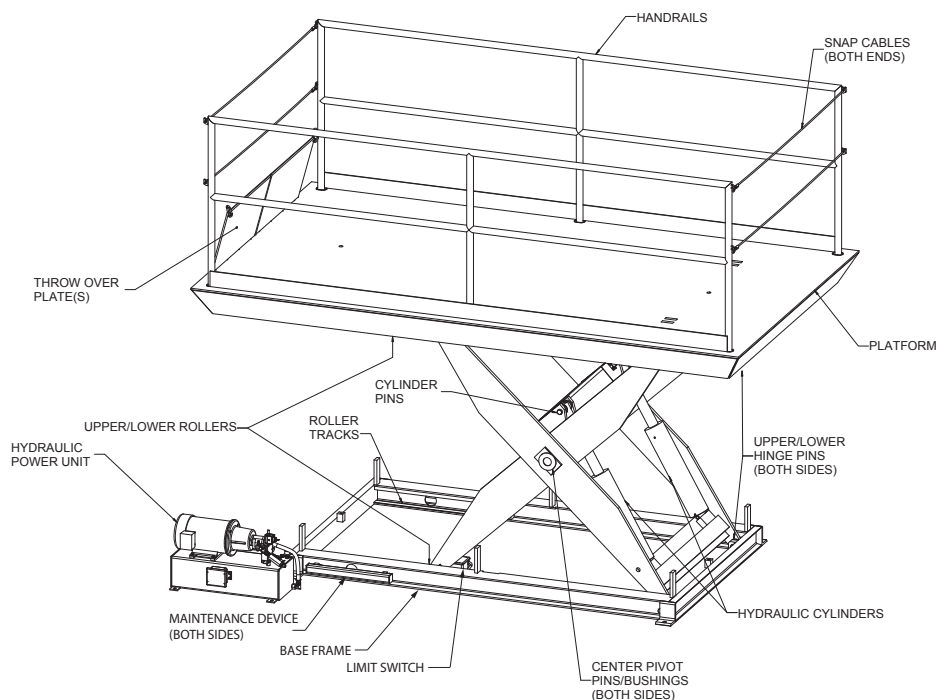

### 6.3 Relieving Hydraulic Pressure

If the machine is operating normally, hydraulic system pressure can be relieved by lowering the platform to the fully lowered position or on maintenance device and continuing to hold the down button for five to ten seconds.

If the hydraulic power unit is not receiving power the platform can be lowered using the manual override located on the down valve.

**If the platform is raised and will not lower:**



**Crush Hazard – Do not enter under the platform.**

**Remove load before performing any maintenance or repair.**

**Disconnect and lockout electrical power before performing maintenance or repair.**

**Failure to securely block the platform from lowering will allow the platform to fall uncontrolled when system pressure is relieved, causing severe injury or death - use only supplied maintenance device.**

**High pressure fluid can cause severe injury or death. Always use proper personal protective equipment when performing any maintenance or repair.**

1. Thread the lifting eyes into holes on the platform for manually raising the platform (holes off the center line of the platform). See **General Installation Section numbers 1-5**.
2. Attach chains/ straps and load spreader to the lifting eyes.
3. Using an appropriate lifting device, slowly pull the chains/ straps until they are taught and will support the platform when hydraulic pressure is relieved. If the platform is not in the fully raised position, continue to pull the platform up until it reaches the fully raised position.

#### **NOTICE**

**When lifting the platform by the lifting eyes, ensure cable/chain/straps pull vertically on the lifting eyes.**

4. Ensure platform is secured and will not fall as hydraulic pressure is relieved.
5. Carefully and slowly loosen the hydraulic fitting on the input side of the adjustable flow control shown in the diagram to relieve system pressure. Use an appropriate, clean, container to catch hydraulic fluid in the hoses. Use an oil absorbent to clean up any spills. Uncontaminated fluid can be reused.
6. Engage the maintenance device. - See **Maintenance Devices section**.
7. Slowly lower the platform until resting on the maintenance device.

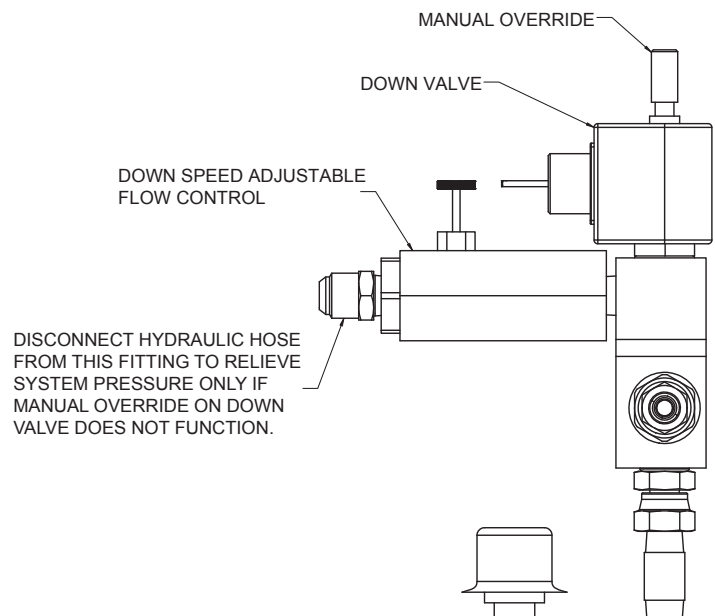

## 6.4 Replacement Parts

Southworth Products has carefully chosen the components in your lift to be the best available for the purpose. Replacement parts should be identical to the original equipment. Southworth Products will not be responsible for equipment failures resulting from the use of incorrect replacement parts or from unauthorized modifications of the machine.

Southworth Products will gladly supply you with replacement parts for your Southworth Products lift. With your order, please include the model number and the serial number of the lift. You can find these numbers on the name plate, which is located on the crossbar at the base of the cylinder(s). When you are ordering parts for a cylinder, also include the cylinder number. This is stamped on the base of the cylinder housing.

To order replacement parts, please call the Parts Department. See Warranty & Contact Information section. Parts are shipped subject to the following terms:

- FOB factory
- Returns only with the approval of our parts department.
- Payment net 30 days (except parts covered by warranty).
- Freight collect (except parts covered by warranty).
- The warranty for repair parts is 30 days from date of shipment.

Parts replaced under warranty are on a “charge-credit” basis. We will invoice you when we ship the replacement part, then credit you when you return the worn or damaged part, and we verify that it is covered by our warranty. Labor is not covered under warranty for Parts orders.

## 7. Troubleshooting

PROBLEM	POSSIBLE CAUSE	CHECK
Lift will not raise	Motor may be turning in wrong direction.	Swap any two phases of the motor power leads.
	Load too heavy	Make sure the load does not exceed the rated capacity.
	Power unit not receiving power.	Verify that the power unit is receiving power. <b>See Electrical Information Section.</b>
	Hand controls may be malfunctioning or may not be receiving power.	Verify that the controls are receiving power and are functioning correctly. <b>See Electrical Information Section.</b>
	Motor contactor may be malfunctioning.	Verify motor contactor is functioning. <b>See Electrical Information Section.</b>
	Hydraulic Fluid low	With lift in fully lowered position the fluid level should be approximately 3/4” from the top of the tank.
	Lift has reached it upper limit.	Upper limit switch may need to be adjusted
	Motor voltage too low	Supply voltage must be $\pm 10\%$ of the rated voltage at the motor terminals.
	Tank vent plugged	Make sure vent plug on hydraulic tank is installed and not blocked.

PROBLEM	POSSIBLE CAUSE	CHECK
Lift will not raise	Suction filter is clogged	Clean suction filter.
	Vacuum leak in the suction line	Check all fittings and hoses for damage or loose connections.
	Down valve may be energized	Check for correct voltage to down valve and solenoid valve.
	Missing, damaged, or loose coupling between motor and pump.	Check to make sure the coupling between the pump and motor has not been damaged, and is not loose.
	Pressure relief valve is activated.	The pressure relief valve may be activated. – Contact Customer Service for assistance.
	External Hydraulic leak	Inspect all hoses, connections, and cylinders for leaks.
Lift fails to hold (Drifts down)	Down valve may be leaking internally.	Remove the down valve and inspect for debris which may be preventing it from closing. <b>Contact Customer Service for procedure.</b>
	Down valve may be energized	Check the solenoid with a volt meter.
	Cylinder may be leaking	Check for fluid leaks.
Lift will not lower	Down valve may not be energized	Check for power to the solenoid valve with a volt meter while pressing the down button.
	Down Flow control may need to be adjusted	Adjust down flow control as needed.
	Velocity fuses may be activated.	Contact customer service for procedure to correct. Ensure up limit switch is properly adjusted to prevent machine from powering into the up stops.
Lift raises too slowly	Voltage may be low	Check voltage at motor. Supply voltage must be $\pm 10\%$ of the rated voltage at the motor terminals.
	Suction filter, breather cap, or pressure line may be clogged	Remove necessary components and clean.
	Pump may be overheating due to insufficient oil	Check fluid level and viscosity.
	Pressure relief valve is activated.	The pressure relief valve may be activated. – Contact Customer Service for assistance.
Lift lowers too slowly	Down valve may not be fully opening or may be partially blocked or stuck closed.	Remove the down valve and clean. - <b>Contact Customer Service for procedure.</b>
	Flow control may need to be adjusted	Adjust the flow control as necessary.

## 8. Electrical Information

Other motor and hydraulic power unit options and configurations are available. If your machine was supplied with a motor other than the one described here or internal HPU contact the manufacturer for more information.

Control Voltage	Primary Voltage	Motor	Full Load Amp
24/1/60	460/3/60	5.0 HP	6.6
	230/3/60		13.2
	208/3/60		14.6

### NOTICE

Components vary according to primary voltage. Contact customer service for required components and settings before changing primary voltage.

Machines equipped with standard controls function only when controls switches are closed. See schematic provided in the control panel or contact the manufacturer for non standard controls.

The motor receives power only while up control switch is closed.

The down valve is energized only when the down switch is closed.

### 8.1 Wiring Schematic

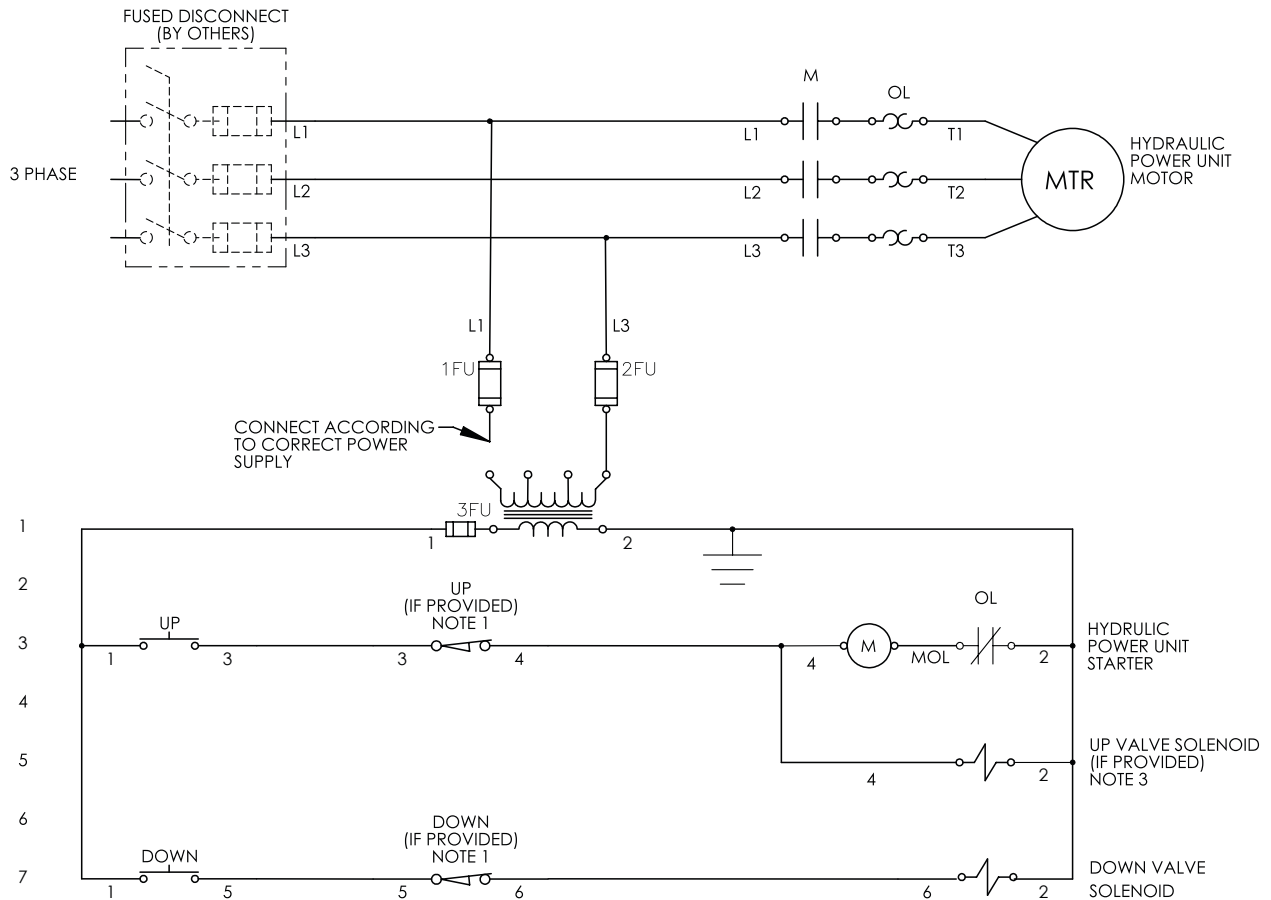

#### NOTES:

- FOR ANY LIMIT SWITCH THAT IS NOT PROVIDED WITH THE EQUIPMENT, ADD A JUMPER BETWEEN THE ASSOCIATED TERMINALS.
- ALTHOUGH PUSHBUTTONS ARE SHOWN, FOOTSWITCHES MAY BE USED.
- IF PROVIDED, AN "UP" VALVE SOLENOID MAY BE CONNECTED IN PARALLEL WITH THE MOTOR STARTER AS SHOWN.

## 8.2 Control Panel

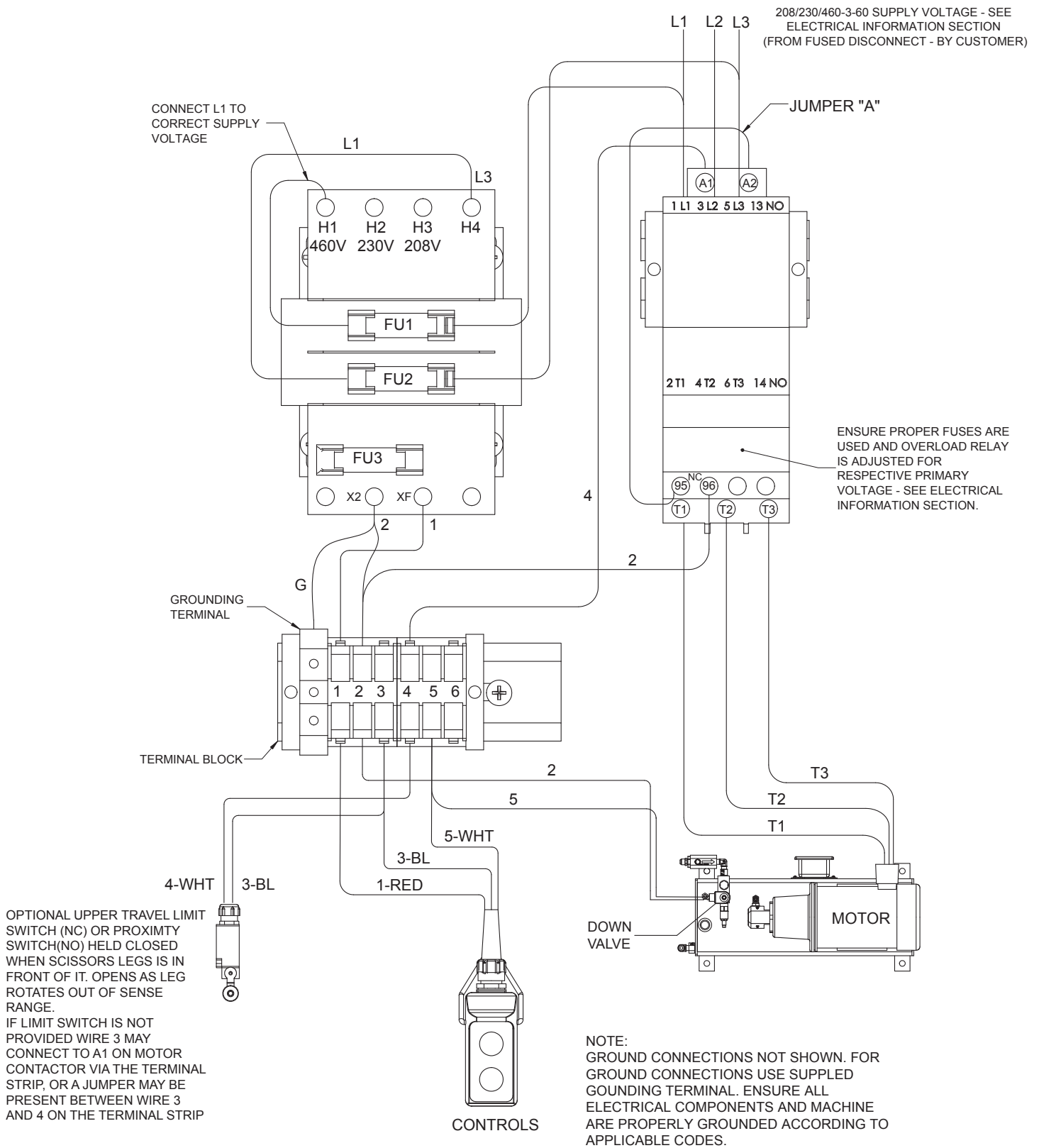

## 9. Hydraulic Information

### **NOTICE**

The system pressure relief valve is pre-set during manufacturing. Do not attempt to adjust or modify.

### 9.1 Hydraulic Fluid Specifications

Standard hydraulic fluid supplied with this machine is Conoco 32. Use only Conoco 32 or equivalent 32 weight hydraulic fluid when replacing or re-filling the reservoir. Unless otherwise specified on power unit reservoir.

### 9.2 Hydraulic Schematic

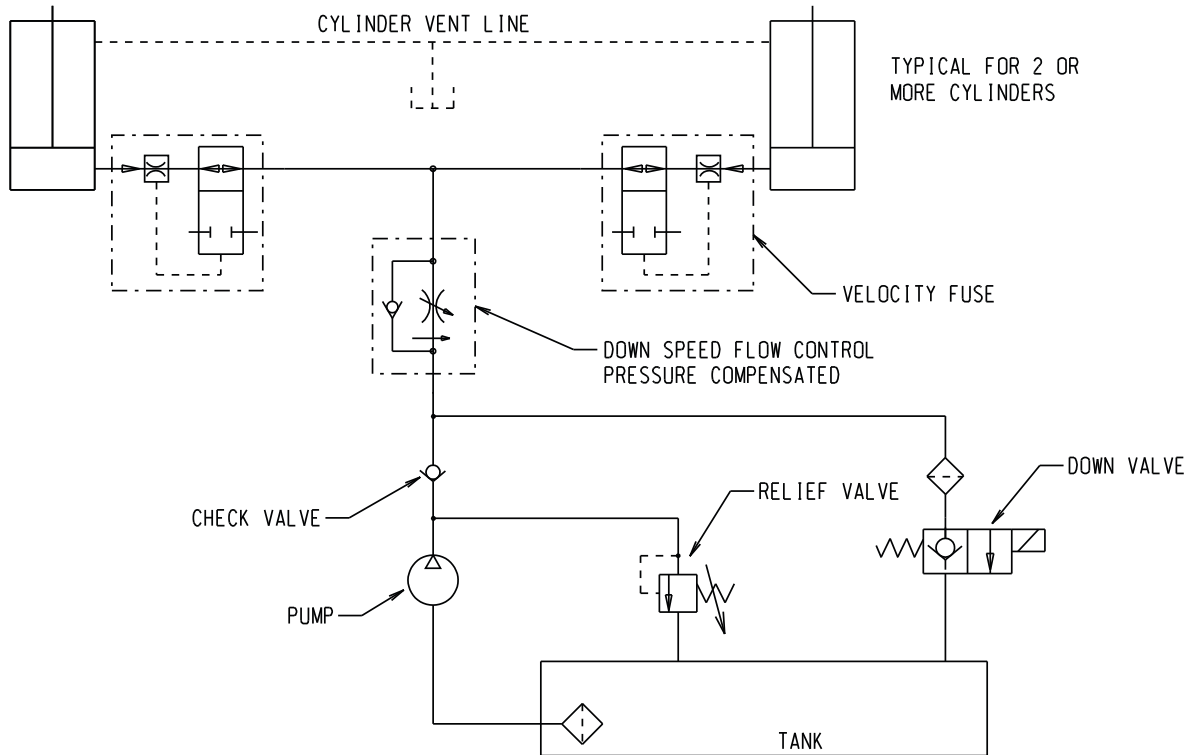

### 9.3 Hydraulic Power Unit

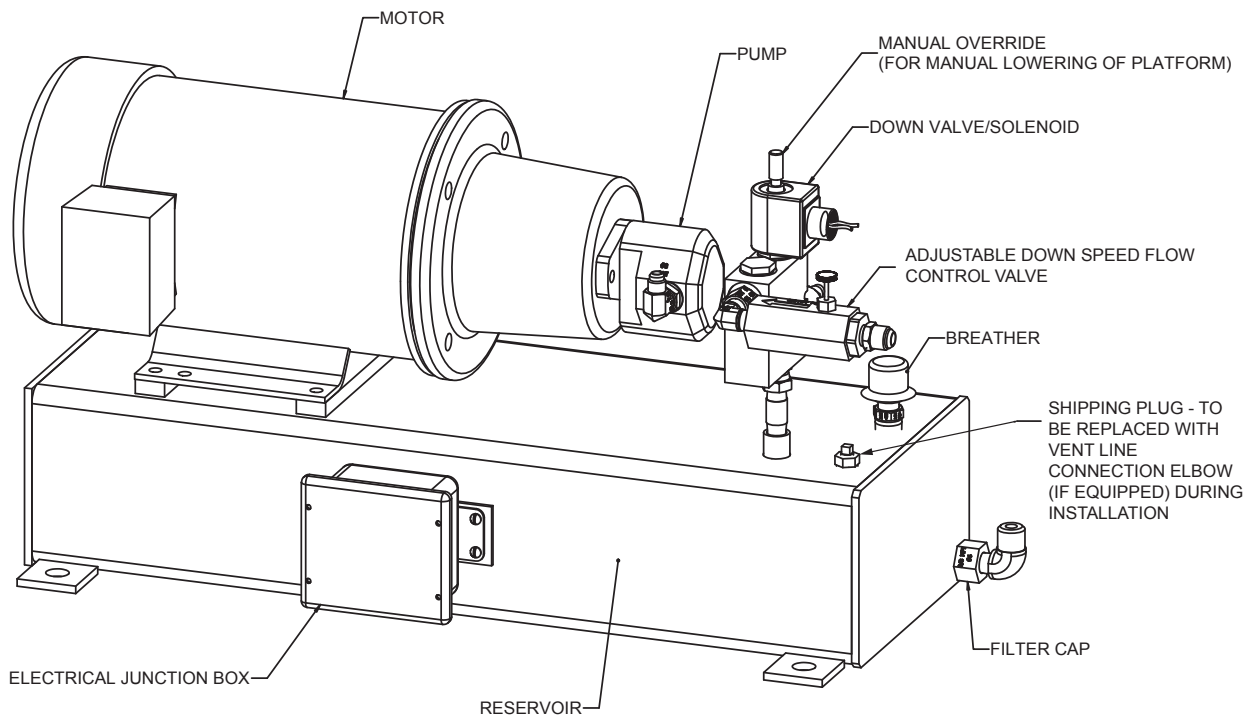

## 9.4 Hose Specifications

MINIMUM OPERATING PRESSURE RATING 3,050 PSI, 12,200 PSI BURST PRESSURE.

NOTE:

SOME MACHINES ARE EQUIPPED WITH BREATHERS ON THE CYLINDERS INSTEAD OF VENT LINE CONNECTION TO TANK.

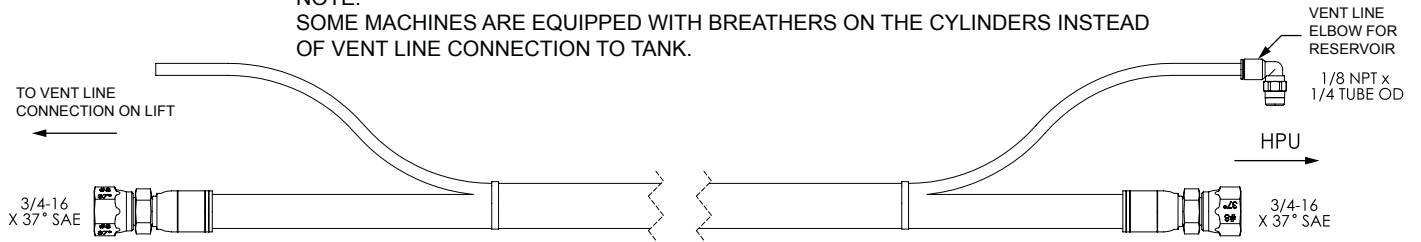

## 9.5 Hydraulic Arrangement

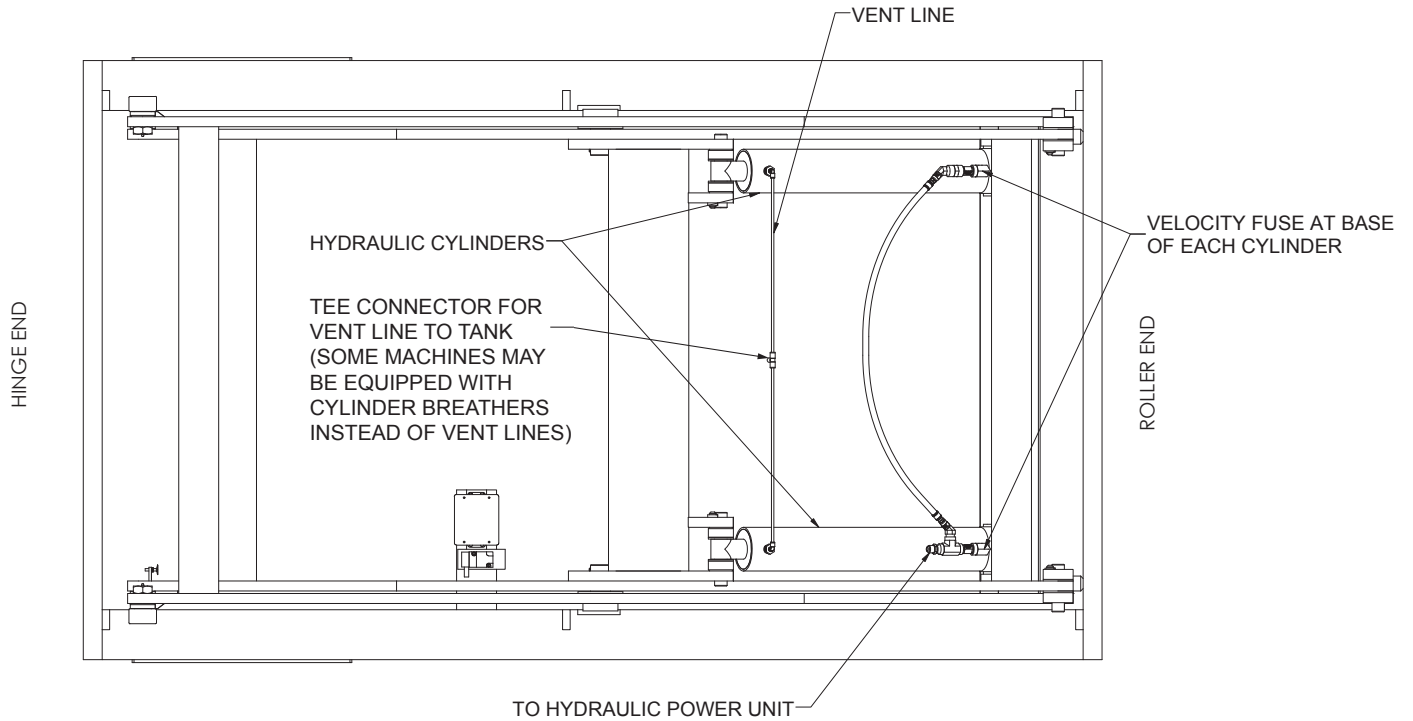



## 10. Warranty & Contact Information

Southworth Products warrants this product to be free from defects in material or workmanship for the duration of the warranty period. Warranty periods vary and begin on the date of shipment. For specific warranty information, contact Southworth Products with the machine's serial number.

Any claim for breach of this warranty must be received in writing by Southworth Products within the warranty period. Warranties shall not cover failure or defective operation, caused by misuse, misapplication, negligence or accident, exceeding recommended capacities, or any alteration or repair of the item purchased which has not been authorized by Southworth Products. Except as set forth herein, Southworth Products makes no other warranties, express or implied, including THE WARRANTIES OF MERCHANTABILITY AND OF FITNESS FOR A PARTICULAR PURPOSE, all of which ARE HEREBY EXCLUDED.

Southworth Products meets the labeling requirements of California's Proposition 65. Southworth Products makes no warranty or representation with respect to the compliance of any product with other State or local safety or product standard codes and any failure to comply with such codes shall not be considered a defect of material or workmanship under this warranty. Southworth Products shall not be liable for any direct or consequential damages arising out of such non-compliance.

Southworth Products' obligations under any warranty or for any other damages which may arise under any sale, agreement, or contract, are limited to the replacement or repair of defective components at its factory or another location at Southworth Products' discretion. This is buyer's sole remedy under any such warranty, sale, agreement, or contract. Southworth Products will not be liable for consequential, incidental, exemplary, or punitive damages of any kind resulting from a breach of any warranty that it has provided or for breach of any term of any sale, agreement, or contract. Any warranty may be altered only in writing by Southworth Products.

# **SOUTHWORTH**

SOUTHWORTH PRODUCTS CORP.  
P.O. Box 1380, Portland, ME 04104-1380  
Telephone: 800-743-1000 • 207-878-0700  
Fax: 207-797-4734  
[www.SouthworthProducts.com](http://www.SouthworthProducts.com)